

_____ 's Whysheet for
Your name

Why do objects slow down?

Yeah, why? Write (or draw) your answer:



Whybricks

Giving physical science form

Document number: 3.2.3.7.1.1 Rev 1.0

Part 1: The triangle

For the first part of this investigation, you will need the triangle.

Build it!

First, build the triangle out of Whybricks.

 **Grab this resource!** 

The **Triangle** build guide.

Make a prediction, then run a test

For this test you will need a timer, your triangle and somewhere to put your triangle, like your desk, a table or the floor. Read what the test is, write down your prediction and then run the test.

To run the test, set your timer for 20 seconds. Once you put your triangle down, start the timer and observe the triangle for the full 20 seconds. **What do you think the triangle will do?**

Write down your prediction:

Now, run the test. If you want, you can run it more than once.

I notice...

What do you notice about this phenomenon? Write your observations on your Notice sheet.

I wonder...

What are you now wondering about? Write your questions on your Wonder sheet.



Part 2: The fidget spinner

For the second part of this investigation, you will need the fidget spinner.

Build it!

First, build the fidget spinner out of Whybricks.

 **Grab this resource!** 

The **Fidget spinner** build guide.

Once it's built, test it out. Your fidget spinner has a long handle. Put your fidget spinner down on your desk and hold it in place using the handle. With your other hand, give the spinner bar a flick.

Make a prediction, then run a test

For this test you will need a timer, your fidget spinner and a flat surface to place and use your fidget spinner, like your desk or a table. Read what the test is, write down your prediction and then run the test.

To run the test, set your timer for 20 seconds. Set up your fidget spinner, holding it in place with one hand. Start the timer, give the spinner bar a flick and observe what happens to your fidget spinner for the full 20 seconds. **What do you think will happen?**

Write down your prediction:



Now, run the test. If you want, you can run it more than once.

 **I notice...**

What do you notice about this phenomenon? Write your observations on your Notice sheet.

 **I wonder...**

What are you now wondering about? Write your questions on your Wonder sheet.

What is going on?

What is causing the objects to behave the way they did?

Investigate **Newton's first law of motion**, also called the law of inertia.

 **Grab this resource!** 

The **Newton's first law** WOW sheet.

Explain the **law of inertia** using the triangle and fidget spinner as examples:



I wonder... Do all outside forces change an object's motion in the same way?

Get your fidget spinner again.

Tinker and experiment with the fidget spinner. Try gently tapping the spinner bar, then flicking it hard. You could even try blowing on the spinner bar.

There is a relationship between force and motion, which is explained in **Newton's second law of motion**.

Newton's second law of motion tells us that to get an object to accelerate, a force must be applied. It also explains why different forces change an object's acceleration in different ways.

I notice...

What do you notice about this phenomenon? Write your observations on your Notice sheet.

Grab this resource!

The **Newton's second law** WOW sheet.

Explain why applying different force to the spinner bar will give different results using **Newton's second** law:

Part 3: The fidget flipper

For the final part of this investigation, you will need the fidget flipper.

Build it!

First, build the fidget flipper out of Whybricks.

 **Grab this resource!** 

The **Fidget flipper** build guide.

Once it's built, test it out. Place it on a flat surface, like a desk, a table or the floor. Tinker and experiment with the fidget flicker. Try gently tapping the flipper bar, then flicking it hard.

What do you notice about what the flipper bar does when it hits the flat surface beneath it? Why does it do that?

 **I notice...**

What do you notice about this phenomenon? Write your observations on your Notice sheet.

What is going on?

The flipper bar and the flat surface below your fidget flipper are interacting in a very specific way. This interaction is explained in Newton's third law of motion.

Investigate Newton's third law of motion.

 **Grab this resource!** 

The **Newton's third law** WOW sheet.



Explain what the statement '**for every action, there is an equal and opposite reaction**' means using the fidget flipper as an example:

So... why do objects slow down?

Now that you've completed this investigation, what do you think about your original answer? Can you add any new information to your original explanation?

And... what are you wondering about now?

Now I wonder...

Now that you have completed the investigation, what new questions do you have?



Triangle

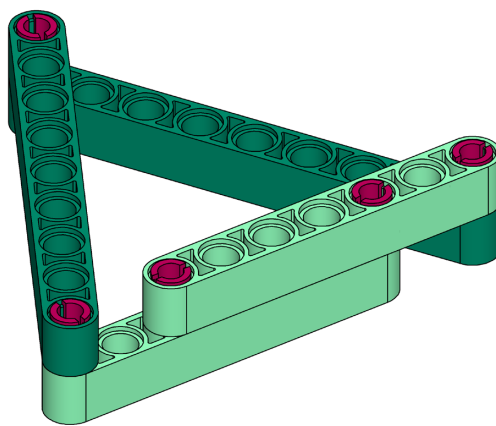

Whybricks
Giving physical science form

Parts

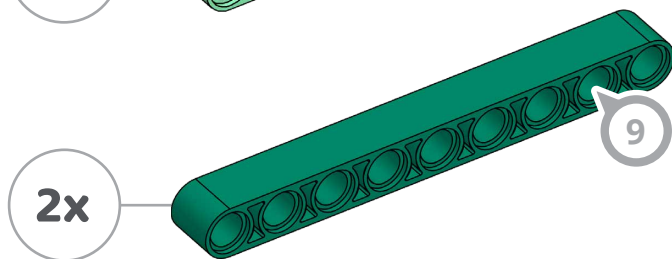
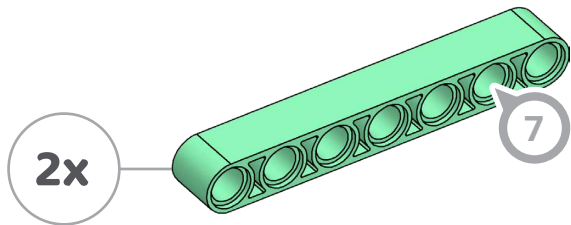
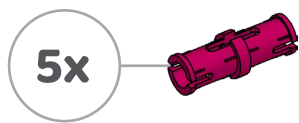

1

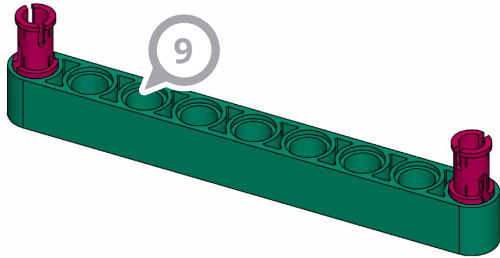

2

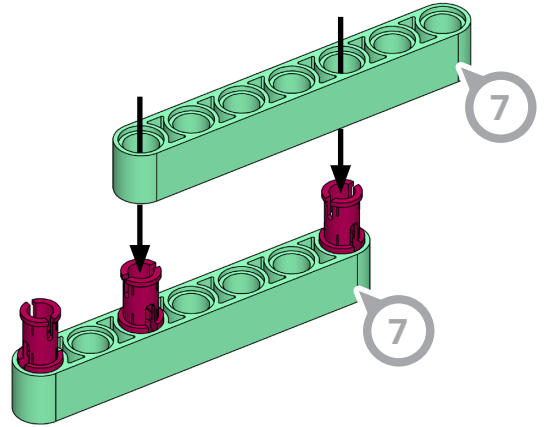

3

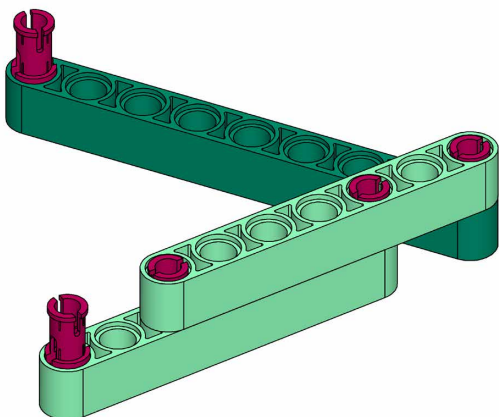

4

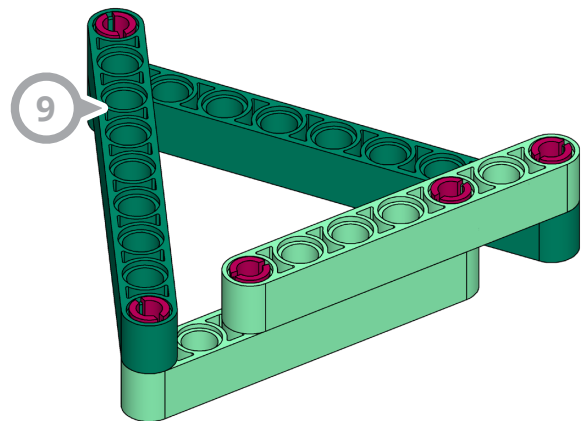

Fidget spinner

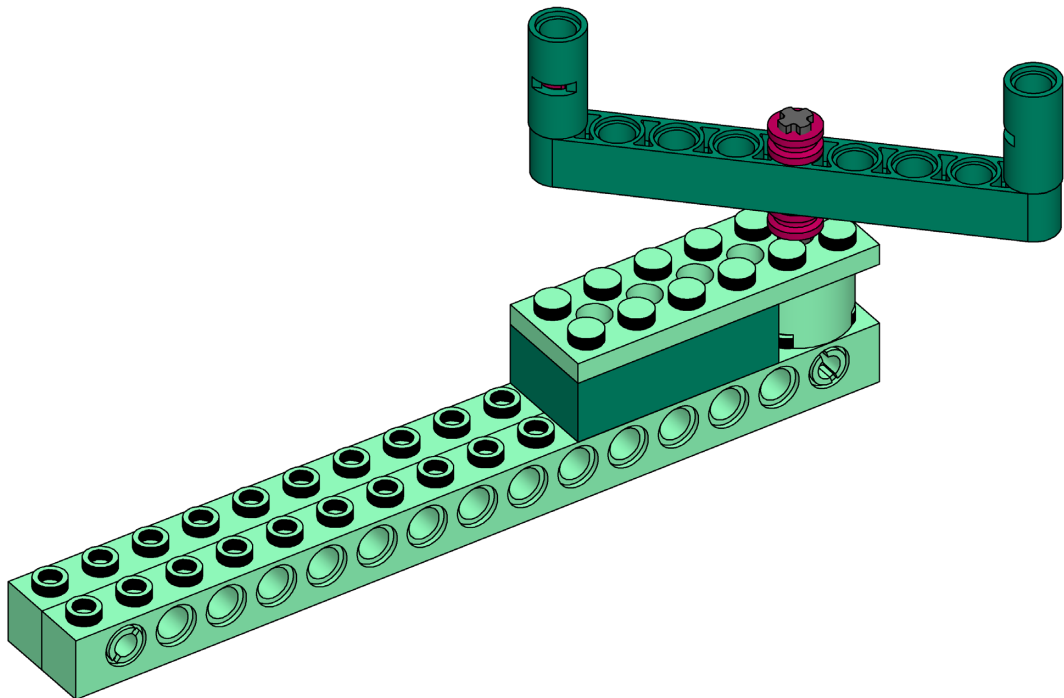

Whybricks
Giving physical science form

Parts

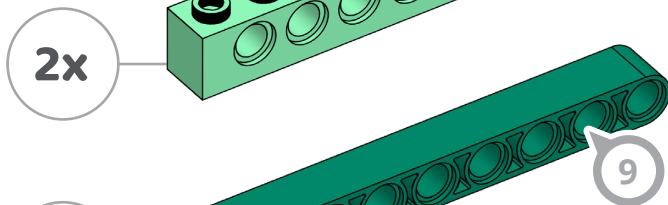
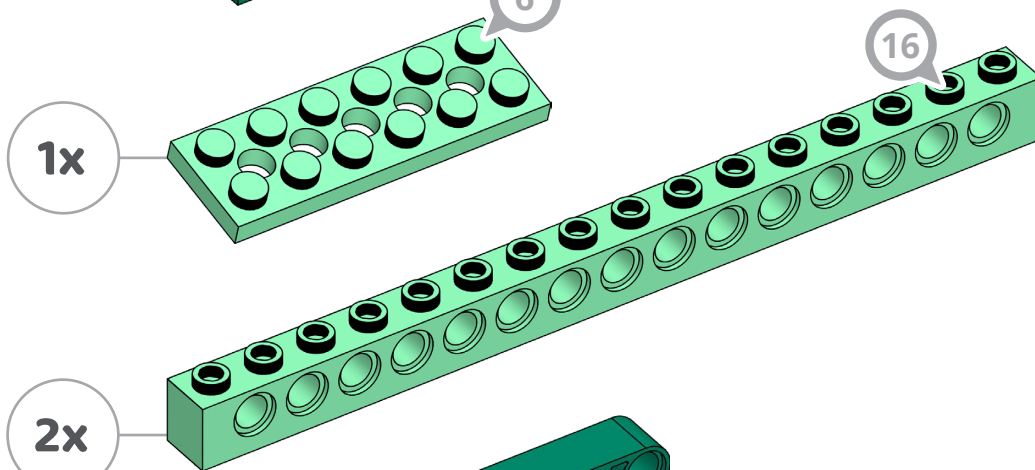
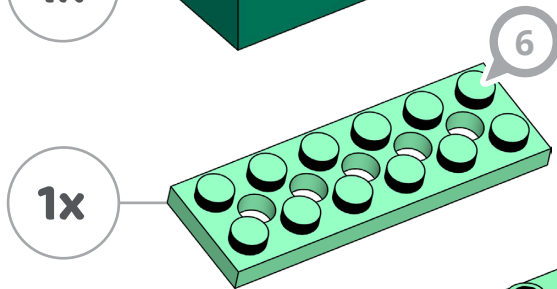
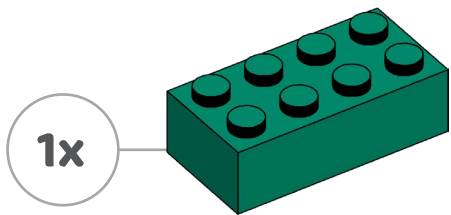
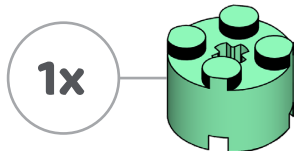
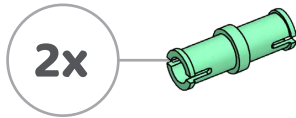
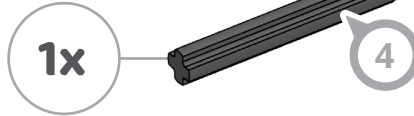
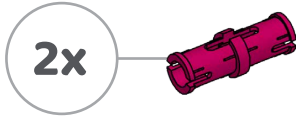
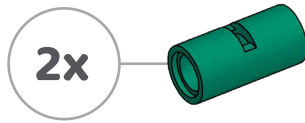

1

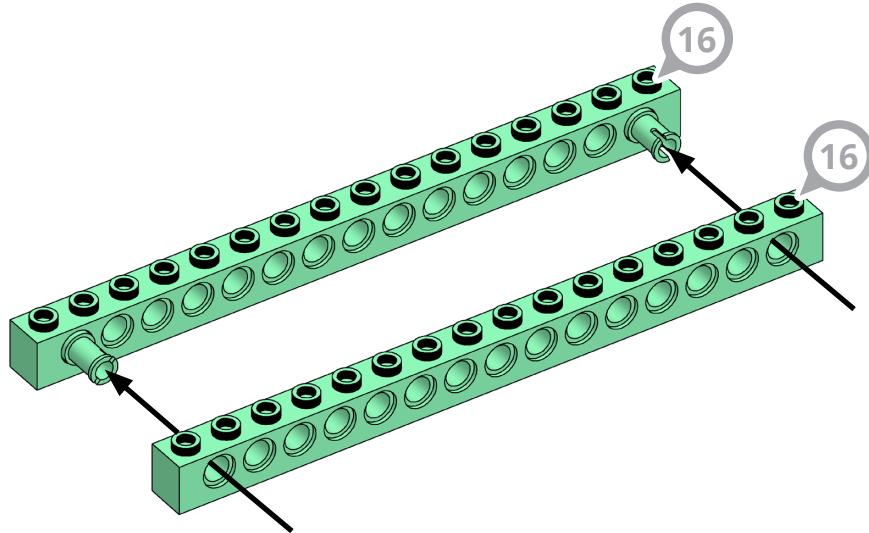

2

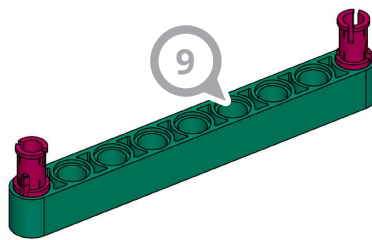

3

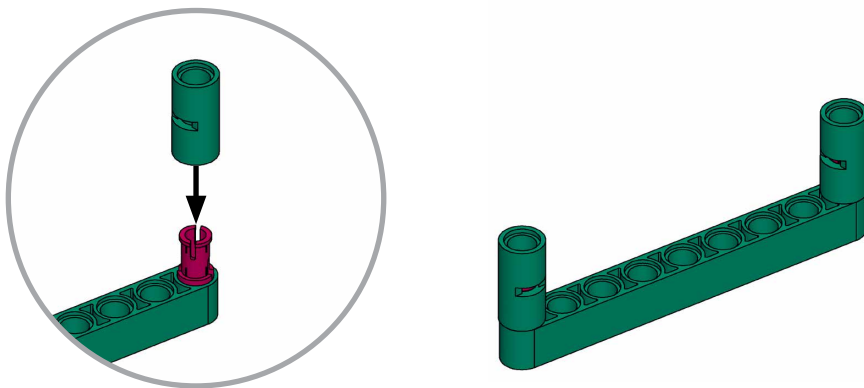

4

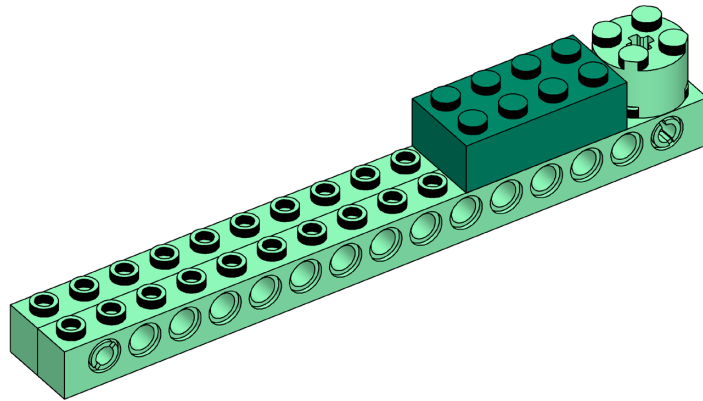

5

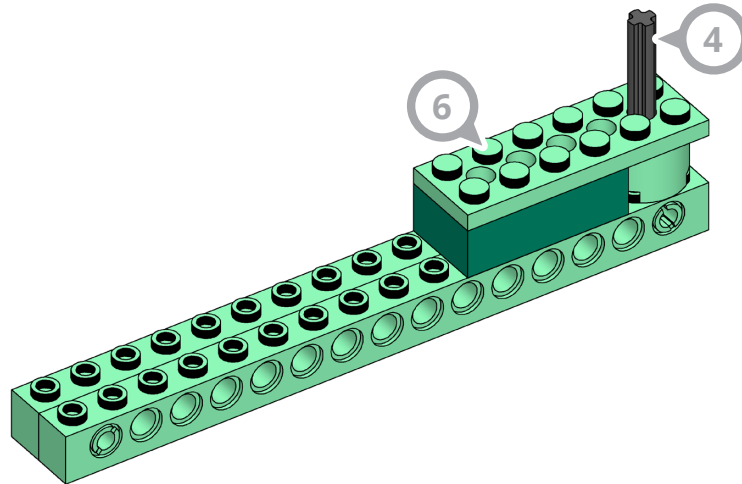

6

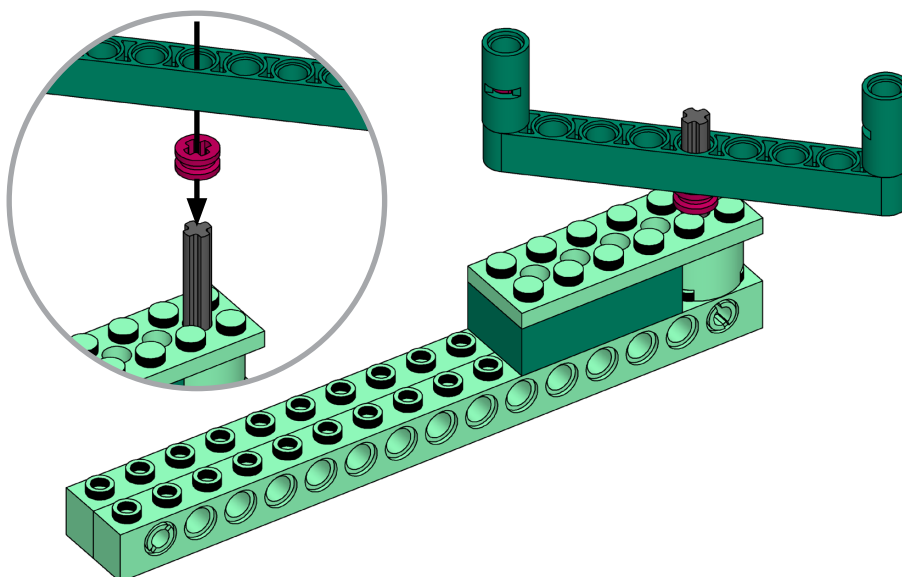

7

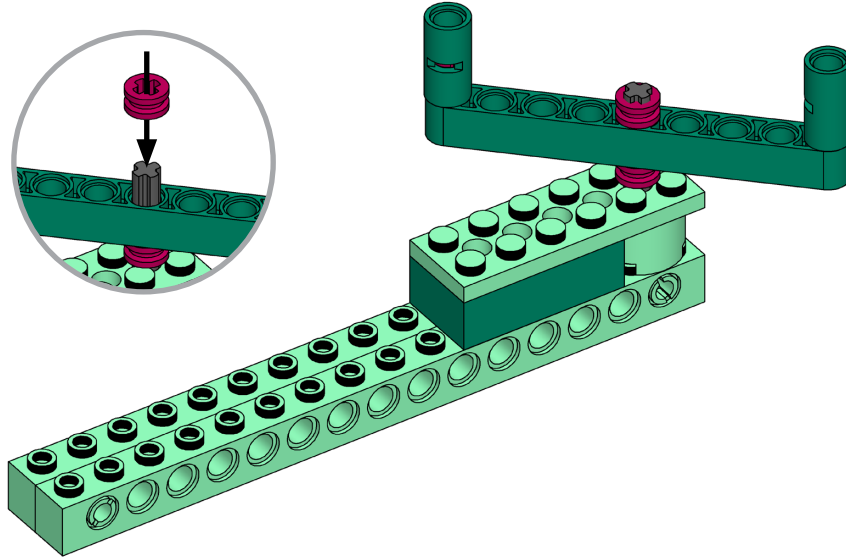

Fidget flipper

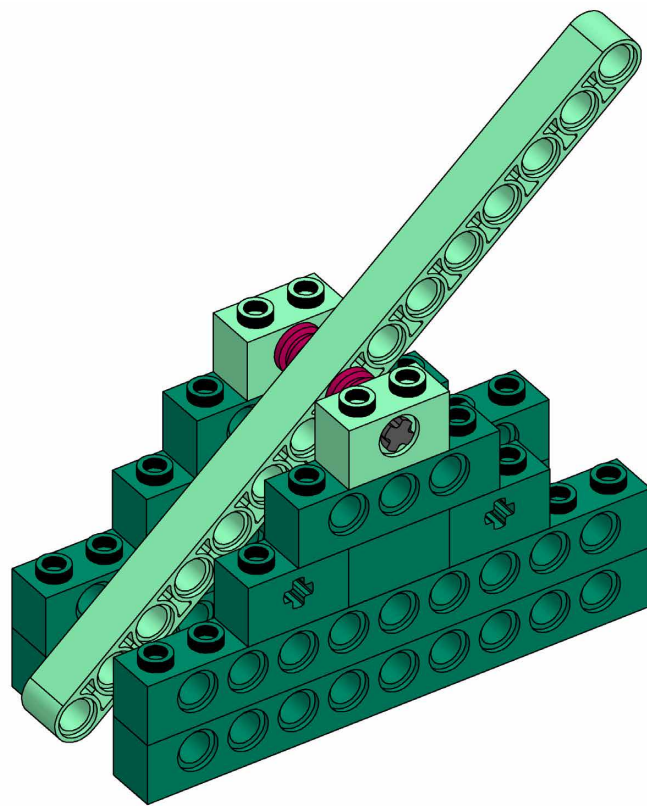

Whybricks
Giving physical science form

Parts

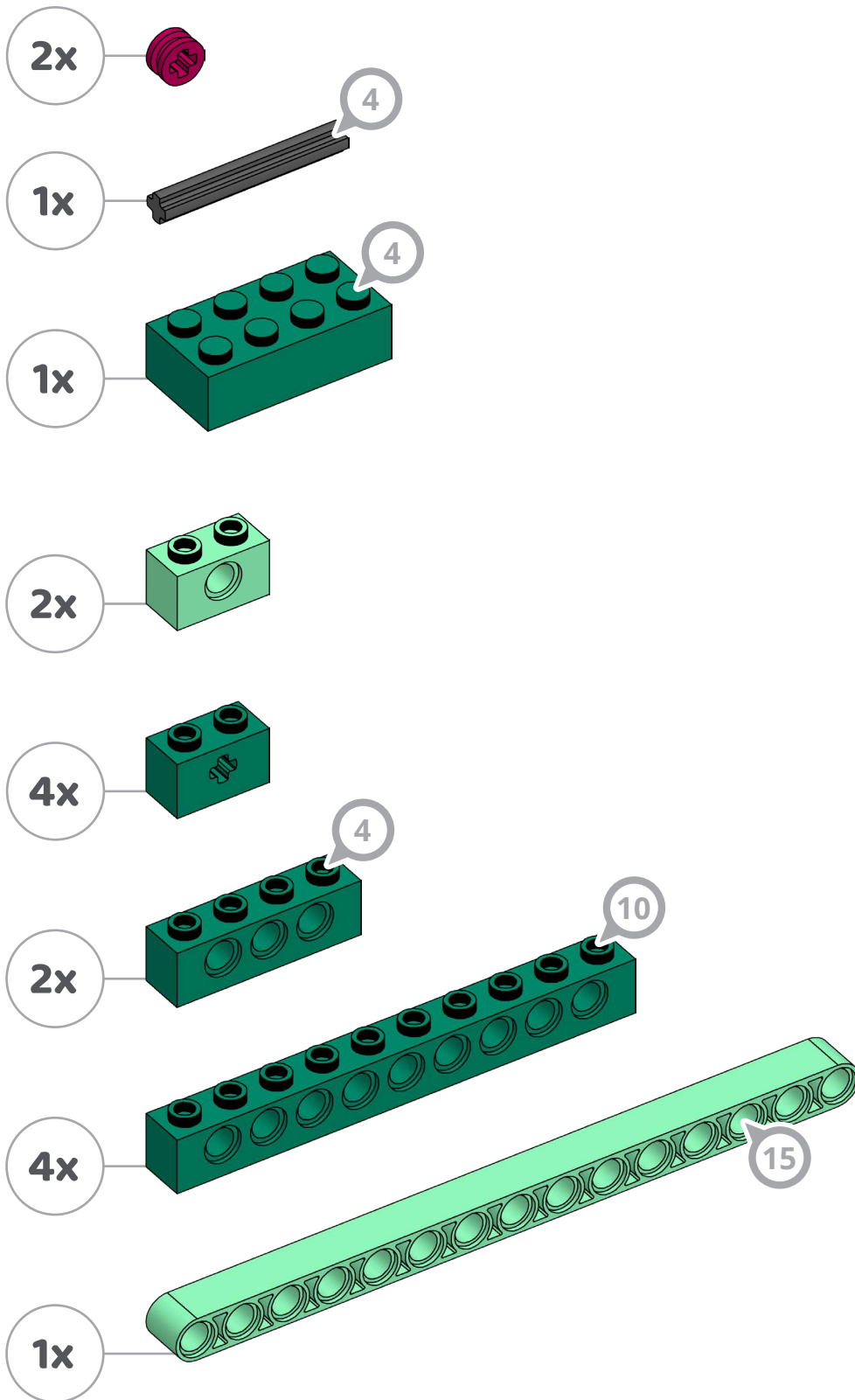

1

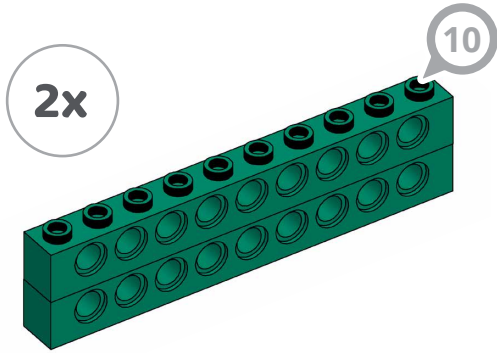

2

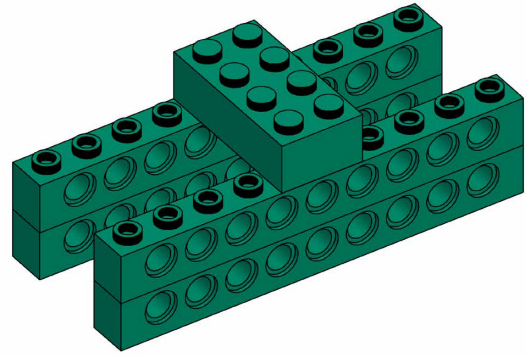

3

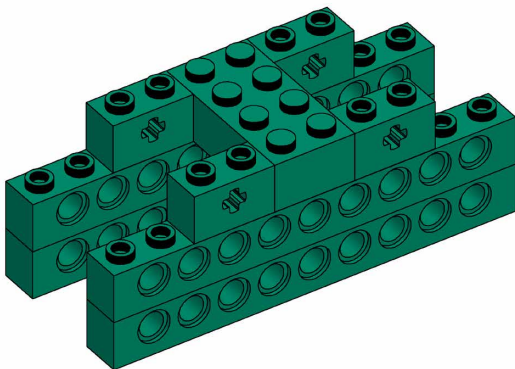

4

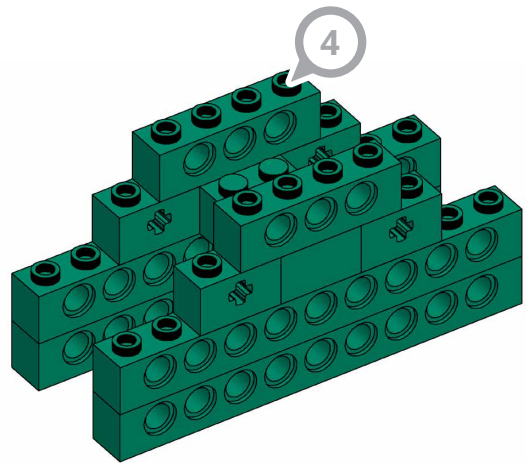

5

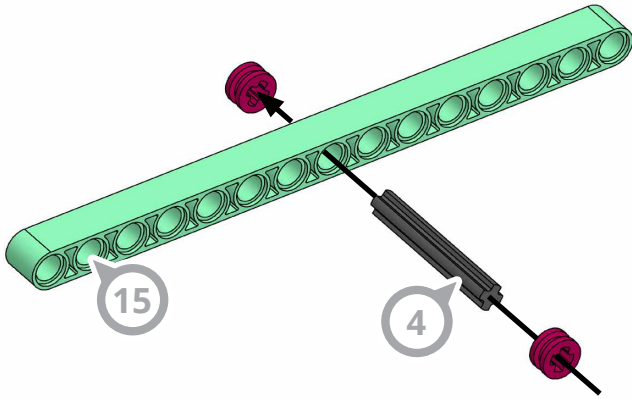

6

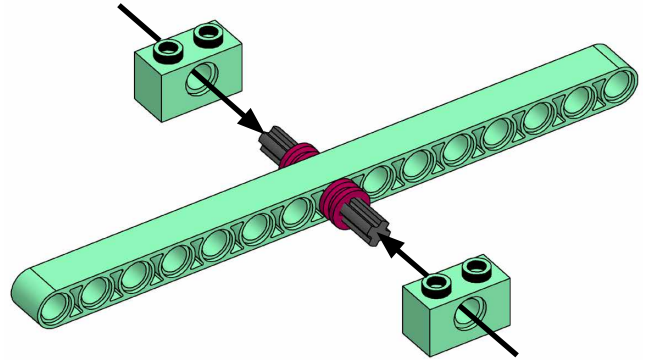

7

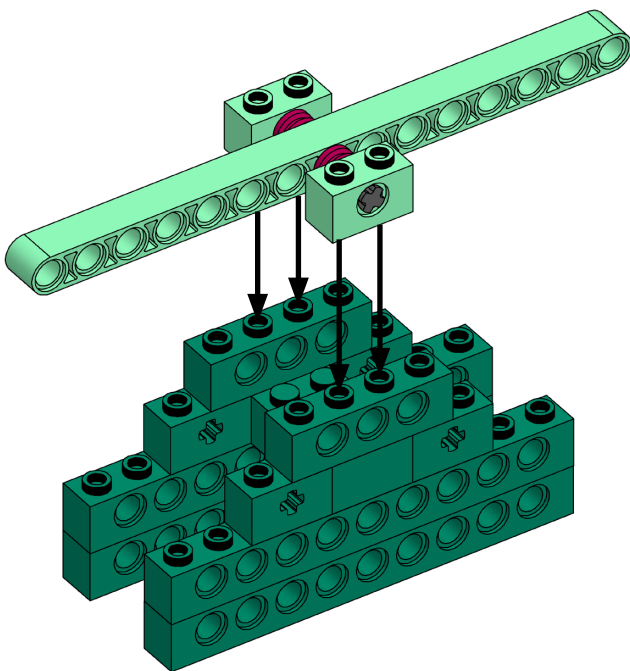

8

