

Portable Sound System

OWNER'S MANUAL

IMPORTANT SAFEGUARDS



CAUTION: To reduce the risk of electric shock, do not remove the cover. No user-serviceable parts inside. Refer servicing to qualified personnel.

WARNING: To prevent fire or electric shock, do not expose this equipment to rain or moisture.

CAUTION: To reduce the risk of fire, replace only with same type fuse. (See specifications).

EXPLANATION OF GRAPHICAL SYMBOLS



The lightning flash with arrowhead symbol, within an equilateral triangle, is intended to alert the user to the presence of uninsulated "dangerous voltage" within the product's enclosure that may be of sufficient magnitude to constitute a risk of electric shock to humans.



The exclamation point, within an equilateral triangle, is intended to alert the user to the presence of important operating and maintenance (servicing) instructions in the literature accompanying the appliance.

CONTENTS

| | |
|--|------|
| PRECAUTIONS..... | 2 |
| SYSTEM SETUP..... | 3-4 |
| GENERAL OPERATION..... | 5-6 |
| DIGITAL RECORDER PLAYER OPERATION..... | 7 |
| WIRELESS OPERATION..... | 8-10 |
| SPECIFICATIONS..... | 11 |
| TROUBLESHOOTING..... | 12 |

PRECAUTIONS

Feedback

Feedback is a howling or shrill sound that is self-generated by the sound system. It is caused by microphone pickup of the sound emanating from the speaker and then being re-amplified. Once generated, this can be a self-sustaining phenomenon.

Feedback Causes

- Microphone too close, pointing towards or in front of speaker.
- Volume setting too loud for room.
- Sound reflections from hard surfaces, walls, etc.

Avoiding & Eliminating Feedback

- Point the microphone into a different direction.
- Keep the microphone away from the speaker; position the speaker in FRONT of the microphone;
- Reduce the volume of the sound system. Have all volume controls set to minimum prior to powering on the sound system.
- Place sound dampening material over hard surfaces; curtains or sound dampening foam.

CAUTION: Feedback can be damaging to both your equipment and a person's hearing

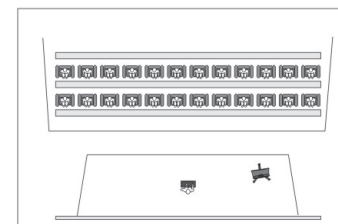

Acceptable

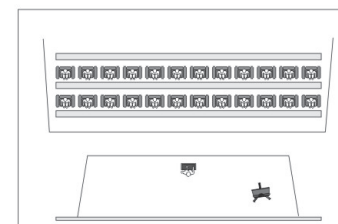

Unacceptable

Setting Up The Sound System

For best results, it is recommended that the PA system be placed above the heads of the audience and above the height of the tallest obstruction using a speaker stand or table. This will benefit the listeners in the rear while minimizing the risk of overpowering the listeners in front.

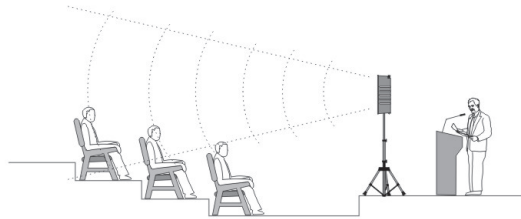

Stand Setup

1. Loosen the Lower Collar Knob.
2. Separate the stand legs until the leg support Cross Braces are parallel to the floor.
3. Tighten the Lower Collar Knob.
4. Extend the center pole by loosening the Upper Collar Knob.
5. Adjust the height and retighten the Upper Collar Knob.
6. Place the sound system on the stand.

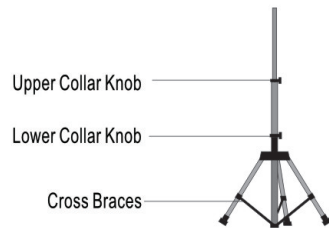

Sound System Placement

The ideal placement of the sound system is between the crowd and the presenter, facing the crowd. This will give the audience a direct signal path and keep the person with the microphone behind the sound system, helping to prevent feedback from occurring.

Single Unit Application

Place the unit along the aisle with the least amount of pedestrian traffic. Point the unit towards the center of the audience.

Two Unit Application

Place each unit along the aisles pointing just off the centerline of the audience. With the sound system placed properly over the head of the crowd, this should be sufficient coverage.

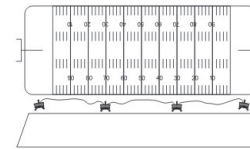

High School Football Stadium/Stands

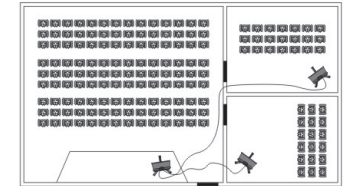

Auditorium/ Outdoor Assembly/City Hall

Sound System Connection

The second method would be to utilize the line-output feature. Simply connect an RCA cable from the line-out of the primary unit to the line-in on the secondary powered unit. Set the volume of the second unit to maximum so that full volume control will be at the primary sound system.

NOTE: Auditoriums or outside areas with large exposed walls or patios may create multiple reflections of the original sound. Altering the sound system position will minimize the sound reflections.

Control Panel

1. Set all input level controls to minimum and tones controls to flat or middle position before turning on the power. Turn the Player Power switch to ON position.
2. Plug a microphone into Mic 1 or Mic 2, or plug an audio source into the Line-in input jack.
3. Press POWER on. The red LED near the switch will light.
4. Slowly increase the level control adjacent to the input jack used to desired volume.
5. For speech applications, Speech Mode should be "on" to overcome ambient noise. For standard applications (music and indoors), Speech Mode should be "off".
6. Adjust Bass and Treble controls for desired sound quality.

NOTE : Instructions for wireless operation can be found on page 11

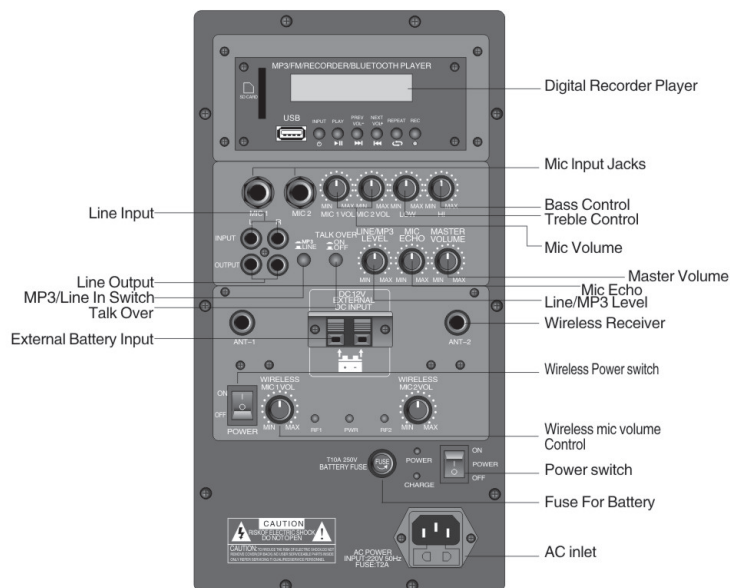

Mic 1 , Mic 2



This balanced 1/4" jack, low impedance input is for use with balanced microphone to help prevent hum or interference when using a long cable.

Line Input



The unbalanced, high impedance RCA input is used for playback of a cassette or CD player, musical instrument, VCR, other sound system or similar line-level signal source. This input may be used in conjunction with other inputs for a composite output.

Line Output



The balanced Line-out provides a combined signal of all inputs being used. You can use this function to "daisy chain" another powered sound system to this unit for greater crowd coverage. Note: This output is post source level; any volume fluctuations for a specific input will affect the output signal level at this output.



Talk Over

The Talk Over button allows you to customize the sound output of this unit for a particular application:



Power Button

Press to on to turn on power.
Press to off to turn the power off.



AC Inlet

Connects to the supplied power cord.



Fuse terminal

This terminal is the fuse for internal battery



Mic Volume

Adjust the microphone level.



Bass Control

Adjust bass response. Rotate clockwise to increase bass output and counter clockwise to reduce it. The center position provides flat characteristics.



Treble Control

Adjust treble response. Rotate clockwise to increase treble output and counter clockwise to reduce it. The center position provides flat characteristics.



Master Volume

Adjust the overall signal level.



Mic Echo Control

Adjust the level of echo applied to the mic channels.



Line/MP3 Level

Adjust the Line in and MP3 player level



MP3/Line In Switch

Switching between the Line in and Mp3 player

The Digital recorder records to MP3 compression format, high sample rate at 196 KHz, 128Kbps. The audio signal is fed directly into the mixing bus, mixing it directly with all other inputs of this unit for a composite output. And have bluetooth function

CAUTION: To avoid noise at shut off, turn player off before you turn off the unit.



General Operation



POWER ON/OFF AND INPUT SELECT When push and hold the button, the power can be turn on/off; push the button for select USB/SD/FM/Bluetooth; The pairing code for Blue tooth is 7456.



PLAY/PAUSE - Press to play a track. Press this button while track is playing to pause play, press again to resume.



Push the REC key to record, and then push the again to stop record. When Push the REC button, the LCD will show the recording time "REC :00:01". After stop the record, the player will auto play the recent recording track.



FORWARD - Press to fast forward on the current track.



BACKWARD - Press to fast backward on the current track.



REPEAT

Push the REPEAT key can select the repeat mode from "one" to "ALL".



USB port: Insert a USB flash driver for playback of media files. The player will no record without a USB flash driver in this slot.



SD Card Slot: Insert your SD card into this slot for playback of media files, The player will no record without a SD card in this slot.

Wireless

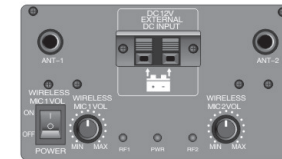

Wireless Power Switch

Power ON/OFF press power to turn the wireless on and off.



Wireless Mic Volume Control

Adjust the microphone level.



Antenna

Receive signals from the transmitter.

Using The Wireless Receiver

- 1、 Turn on the power, The power indicator light will turn on.
- 2、 Make the antennas and the receiver body for a 90° angle .
- 3、 When the handheld microphone on,the receiver "RF" LED is growing.
- 4、 The receiver output volume can be adjusted by the volume control knob.

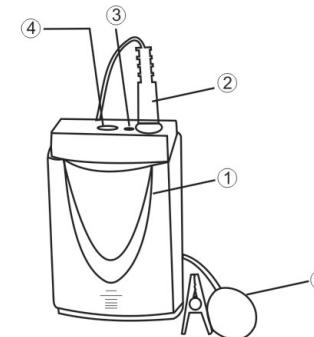

Body-Pack Transmitter

1. **Battery Compartment.**
2. **Microphone Input Connector.** Connector provides connection to a variety of lavalier and headset microphone cables and also as a transmission antenna.
3. **Power and Low Battery Indicator.** When this red light is glowing, you have 20 minutes or less of useful operating time to change the battery.
4. **Power and Mic MUTE ON/OFF Switch.**
5. **Lavalier Microphone.** This can be replaced with a headset microphone or other instrument connecting cables.

USING THE BODY-PACK TRANSMITTERS

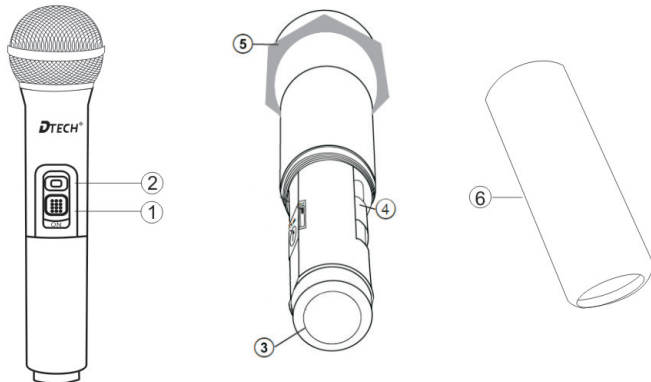

FIGURE 5

NOTE: The body-pack system is designed for use with other equipment, such as lavalier microphones, instrument cables, headset microphones, etc. See your dealer for details on ordering the proper equipment for your needs.

1. Clip the body pack transmitter to your belt or guitar strap.
2. Connect the lavalier microphone, headset or instrument adapter cable to the body-pack transmitter.
3. Turn the transmitter POWER switch on. Check Power/Battery fuel gauge.
4. Check the RF Signal Indicator on the receiver to see if the RF signal is being received.
5. Begin speaking or playing your instrument.
6. During the performance or presentation, slide the ON/MUTE/OFF switch to the MUTE position when the system is not being used.
7. When the performance or presentation is over, slide the transmitter ON/MUTE/OFF switch to the OFF position to conserve battery power.

Handheld Microphone Transmitter



1. Power Button;
2. Power LED Light;

3. Color IC rings;
4. Battery Compartment;

5. Anti-roll ring;
6. Battery Cover.

Using The Handheld Microphone Transmitters

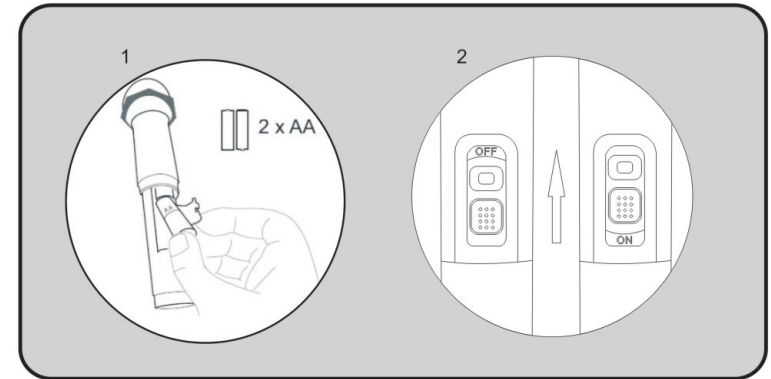

1. Take off the transmitter battery cover to expose the battery terminal. Insert two 1.5V batteries into the battery compartment and then replace the battery cover.
2. Lightly push the power switch to the ON position, the power LED light flash and then turn green. The microphone starts to work. If the LED light does not light, please check whether the polarity of the battery is correct.
3. Replaced the batteries if the power light turn red for the battery voltage not enough.
4. If it is not used for a long time, please take out the batteries in the microphone, so as to avoid battery leaking and damaging the microphone.

TIPS AND TROUBLESHOOTING

Tips for getting the best performance

- Maintain a line-of-sight between the transmitter and receiver antennas.
- Keep the receiver and antennas away from large metal objects.
- Avoid placing the receiver near computers or other RF generating equipment.
- Point the receiver antennas straight up.
- Avoid placing the receiver in the bottom of an equipment rack unless the antennas are remotely located.

FEATURE

- Built-in USB/SD/FM/BUETOOTH mp3 player and recorder
- Built-in 2 channel VHF wireless system
- Built-in power mixer
- Built-in 2 way speaker
- Built-in Auto charger
- Built-in rechargeable battery
- Built-in trolley and roller
- Built-in external battery input socket
- Built-in internal battery fuse.

SPECIFICATIONS

Rated Power Output: 40 watts/4 ohms
Max SPL@ Rated Power: 112 dB
Frequency Response: 80 Hz-15 KHz
Bass/Treble Control: 8dB cut/boost @, 100Hz - 8KHz
Line Input: RCA, Hi-Z, unbalanced;
Mic Input: 1/4" phone, Hi-Z unbalanced
Sensitivity for Rated Output: -14dBV (200 mVrms)
Unbalanced Line Output: -40dBV (10 mVrms)
Balanced Mic Input: XLR, Lo-Z Balanced
Line output(post fader): RCA, Hi-Z unbalanced.
Battery(one): 12 Volt 7.2 AH rechargeable Lead-Acid battery

SPECIFICATIONS SUBJECT TO CHANGE WITHOUT NOTICE.

Having trouble with the sound system?

| Condition | Possible Cause |
|---------------------------------|---|
| No sound (power LED not lit): | - power switch OFF - batteries fully discharged |
| Charge indicator doesn't light: | - blown fuse |
| No sound (power LED lights): | - no output from source - input cable unplugged - input volume control low or off - under the switch mode, the slave speaker out is plug in, but no slave speaker is connected |
| Shortened battery life: | - batteries not fully charged - batteries need replacement |
| Distorted sound: | - poor connection on input cable - input signal too strong |
| Excessive hum or noise: | - input cable not shielded - not using balanced microphone |

Having trouble with the wireless system?

| Condition | Possible Cause |
|------------------------------------|--|
| No sound (TX ON indicator lights): | - wireless volume control low or off - no mic plugged into belt-pack transmitter |
| No sound (TX ON indicator off): | - sound system not turned on - transmitter power switch turned off - low battery or no battery in transmitter - not on same channel |