

Safety Information

WARNING!

- Shock hazard- Never connect the component to the electrical outlets in your home in any way!
- Choking Hazard- Small parts. Not for children under 3 years.
- Tidy away the plastic sheeting in time after unpacking, avoid the children get asphyxiated by playing.
- This product contains a motor. Do not touch the motor or fan during operation. Do not lean over the motor. Do not launch the fan at people, animals, or objects. Eye protection is recommended.
- Use under the supervision of an adult and read all instructions, follow them and keep for future reference.
- Only for use by children age 8 years and older.
- Connecting components incorrectly could cause short circuiting and causing damage to the products.
- Always check your wiring before turning on circuit unattended while the batteries are installed. Never connect additional batteries to your circuits. Discard any cracked or broken parts.

ATTENTION

- This product contains a glass light-bulb. Misuse may cause it to break, resulting in sharp pieces that could result in a cut. Use with caution.
- Please use four AA Batteries, do not connect positive and negative poles directly.
- This kit contains a magnet. Magnets becoming attached to a metallic object inside the human body can cause serious or fatal injury. Seek immediate medical help if the magnet is swallowed or inhaled.

BATTERIES:

- 1) 4 x AA (1.5 volt) batteries are required, which are not included in this kit.
- 2) Only insert batteries once a circuit is complete and has been carefully checked for errors. Always remove the batteries before dismantling the circuit.
- 3) Non rechargeable batteries are not to be recharged.
- 4) Rechargeable batteries should only be charged under adult supervision. and should not be recharged while in the product.
- 5) Different types of batteries or old and new batteries are not to be mixed.
- 6) Remove batteries when they are used up.
- 7) Do not short circuit the battery terminals.
- 8) Never throw batteries in fire or attempt to open its outer casing.
- 9) Batteries are harmful if swallowed, so keep away from small children.
- 10) Do not connect batteries or battery holders in parallel.

Components List

Number	Description	Item	Number	Description	Item	Number	Description	Item
1	One-Snap Connector	 4pcs	19	Battery Holder-uses 1.5V type AA(not included)	 2pcs	42	10 μ f Capacitor	
2	Two-Snap Connector	 8pcs	20	Loudspeaker		43	100 μ f Capacitor	
3	Three-Snap Connector	 3pcs	21	IC for Music		44	470 μ f Capacitor	
4	Four-Snap Connector		22	IC for Alarming		51	PNP Triode	
5	Five-Snap Connector		23	IC for Space War		52	NPN Triode	
6	Six-Snap Connector		24	Motor		53	Varistor	
7	Seven-Snap Connector		26	Green LED		Other : 2.5V Buib, 6V Buib, Magnet, Fan Blade, Circuit board		
11	Buzzer		27	6V Lmp Unit				
12	Touch Plate		28	Microphone				
13	Reed Switch		30	100 Ω Resistor				
14	Button Switch		31	1K Resistor				
15	Switch		33	10K Resistor				
16	Photosensitive Resistor		34	100K Resistor				
17	Red LED		40	0.02 μ f Capacitor				
18	2.5V Lamp Unit		41	0.1 μ f Capacitor				

Component Layout

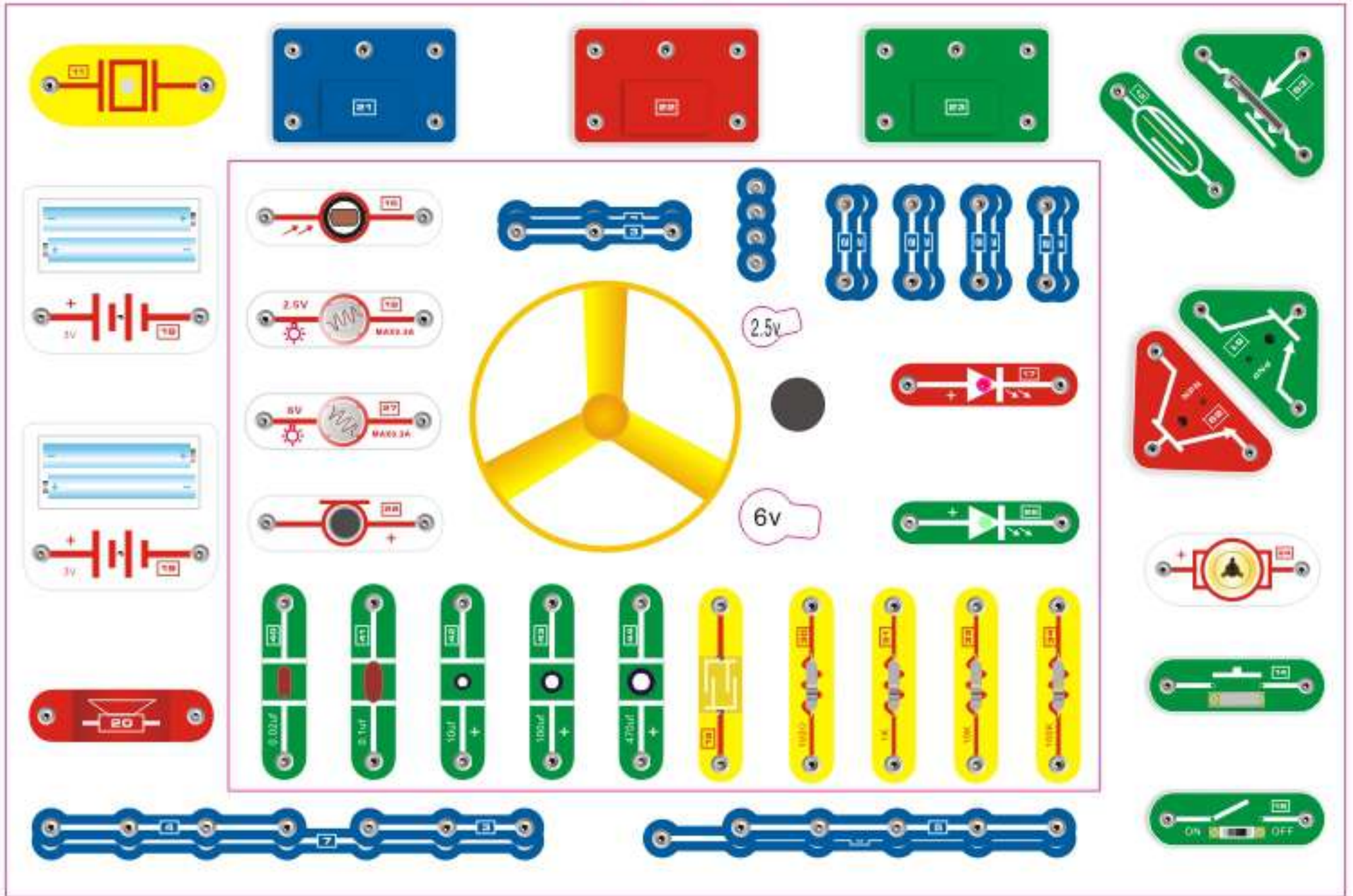

Content

Sequence number and experiments	Page number
1. Lamp(1)-----	1
2. Magnet-controlled lamp(1)-----	1
3. Button switch-controlled lamp(1)-----	1
4. Electric fan-----	1
5. Magnet-controlled fan-----	1
6. Button controlled-controlled fan-----	1
7. Flying saucer-----	1
8. Magnet-controlled flying saucer-----	1
9. Direct and reverse running of motor-----	1
10. Series connection of lamps-----	1
11. Parallel connection of lamps-----	1
12. Series connection of lamp and motor-----	1
13. Parallel connection of lamp and motor-----	1
14. Basic circuit of LED-----	2
15. Magnet-controlled LED-----	2
16. Button switch-controlled LED-----	2
17. Current limiting function of resistor-----	2
18. LED (Light Emitting Diode)-----	2
19. Parallel connection of LED and lamp-----	2
20. Series connection of fan and LED-----	2
21. Parallel connection of LED and fan-----	2
22. Red and green LED-----	2
23. Unidirectional conductivity of LED-----	2
24. Lamp(2)-----	2
25. Magnet-controlled Lamp(2)-----	2
26. Button switch-controlled lamp(2)-----	2
27. Series connection of batteries in the same direction-----	3
28. Series connection of lamp, LED and motor-----	3
29. Parallel connection of lamp, LED and motor-----	3
30. Parallel series of lamp, LED and motor(1)-----	3
31. Parallel series of lamp, LED and motor(2)-----	3
32. Parallel series of two bulbs and the motor(1)-----	3
33. Parallel series of two bulbs and the motor(2)-----	3
34. Parallel series of lamp, LED and motor(4)-----	4
35. Parallel series of lamp, LED and motor(4)-----	4

Sequence number and experiments	Page number
36. Series connection of LED-----	4
37. Power indicator-----	4
38. Conductor tester-----	4
39. Identification of battery polarity-----	4
40. Parallel series of two bulbs and the motor(3)-----	4
41. Parallel series of two bulbs and the motor(4)-----	5
42. Hand-controlled alternative lighting up of lamp and LED-----	5
43. Alternative lighting up of lamp and LED-----	5
44. Alternative working of fan and LED-----	5
45. Alterating light-----	5
46. Magnet-controlled alterating light-----	5
47. Variable speed electric fan-----	5
48. Button switch-controlled variable speed electric fan-----	5
49. Simple telegraph exerciser-----	5
50. Lead continuity tester-----	5
51. Positive and negative rotary-controlling circuits of motors(1)-----	5
52. One switch controls two lamps in series-----	6
53. One switch controls two parallel-connected lamps-----	6
54. Two series-connected switches control one lamp-----	6
55. Two switches in parallel control one lamp-----	6
56. Two series-connected switches control two series-connected lamps-----	6
57. Two series-connected switches control two parallel-connected lamps-----	6
58. Two parallel-connected switches control two parallel-connected lamps-----	6
59. Two parallel-connected switches control two series-connected lamps-----	6
60. Two switches control two lamps respectively-----	6
61. Two switches conduct blending in control two lamps-----	7
62. Three series-connected switches control one lamp-----	7
63. Three parallel-connected switches control one lamp-----	7
64. Three parallel series-connected switches control one lamp(1)-----	7
65. Three parallel-series connected switches control one lamp(2)-----	7
66. Three switches in series control two series-connected lamps-----	7
67. Three switches in series control two parallel-connected lamps-----	7
68. Three switches in parallel control two series-connected lamps-----	7
69. Three switches in parallel control two parallel-connected lamps-----	8
70. Three switches in parallel series control two series-connected lamps(1)-----	8
71. Three switches in parallel-series control two series-connected lamps(2)-----	8
72. Three switches in parallel-series control two parallel-connected lamps(1)-----	8
73. Three parallel-series switches control two parallel-connected lamps(2)-----	8
74. The connection methods for parallel-series control of 3 switches and 2 lamps-----	8

Sequence number and experiments	Page number
(1-13)	8
75. Parallel-series control(2).....	8
76. Parallel-series control(3).....	9
77. Parallel-series control(4).....	9
78. Parallel-series control(5).....	9
79. Parallel-series control(6).....	9
80. Parallel-series control(7).....	9
81. Parallel-series control(8).....	9
82. Parallel-series control(9).....	9
83. Parallel-series control(10).....	10
84. Parallel-series control(11).....	10
85. Parallel-series control(12).....	10
86. Parallel-series control(13).....	10
87. Birthday music.....	10
88. Function of loudspeaker	10
89. Magnet-controlled music doorbell.....	10
90. Hand-controlled music doorbell.....	10
91. Light-controlled music doorbell.....	11
92. Water-controlled music doorbell.....	11
93. Sound-controlled music doorbell.....	11
94. Motor-controlled music doorbell.....	11
95. Magnet-controlled time delay music doorbell.....	11
96. Hand-controlled time delay music doorbell.....	11
97. Sound-controlled time delay music doorbell 1.....	11
98. Sound-controlled time delay music doorbell 2.....	11
99. Touch-controlled time delay music doorbell1.....	11
100. Sound-controlled time delay music doorbell with flash light 1.....	11
101. Sound-controlled time delay music doorbell with flash light 2.....	11
102. Light-controlled time delay music doorbell with flash light.....	11
103. Touch-controlled time delay music doorbell with flash light.....	11
104. Flashing lamp	11
105. Hand-controlled flashing lamp.....	12
106. Magnet-controlled flashing lamp.....	12
107. Light-controlled flashing lamp.....	12
108. Water-controlled flashing lamp.....	12
109. Sound-controlled flashing lamp with time delay.....	12
110. Motor-controlled flashing lamp with time delay.....	12
111. Magnet-controlled flashing lamp with time delay.....	12
112. Hand-controlled flashing lamp with time delay.....	12

Sequence number and experiments	Page number
113. Intermittently flashing color lamp	12
114. Time-delay sound-controlled LED.....	12
115. Time-delay motor-controlled LED.....	12
116. Hand-controlled LED with light.....	12
117. Light-controlled LED (light emitting diode).....	12
118. Water-controlled LED.....	12
119. Magnetic-controlled LED with light.....	12
120. Magnetic-controlled time delay lamp	13
121. Hand-controlled LED with time delay.....	13
122. Light-controlled double flashing lamp.....	13
123. Water-controlled double flashing lamp.....	13
124. Magnet-controlled double flashing lamp.....	13
125. Hand-controlled double flashing lamp.....	13
126. Sound-controlled double flashing lamp with time delay.....	13
127. Motor-controlled double flashing lamp with time delay.....	13
128. Intermittent double flashing lamp.....	13
129. Magnet-controlled double flashing lamp with time delay.....	13
130. Hand-controlled double flashing lamp with time delay.....	13
131. Hand-controlled time-delay music motor.....	13
132. Magnet-controlled time-delay music motor.....	13
133. Singing motor	14
134. Light-controlled music motor	14
135. Water-controlled music motor	14
136. Magnet-controlled music motor	14
137. Hand-controlled music motor	14
138. Sound-controlled music motor	14
139. Sound of patrol wagon.....	14
140. Sound of machine gun.....	14
141. Sound of fire engine.....	14
142. Sound of ambulance.....	14
143. Buddha laugh.....	14
144. Magnet-controlled sound of patrol wagon.....	14
145. Magnet-controlled sound of machine gun.....	14
146. Magnet-controlled sound of fire engine.....	14
147. Magnet-controlled sound of ambulance.....	14
148. Magnet-controlled sound of Buddha laugh.....	14
149. Sound of game machine.....	14
150. Magnet-controlled sound of game machine.....	14
151. Slow pitch sound of machine gun	14

Sequence number and experiments	Page number
152. Magnet-controlled sound of light machine gun	14
153. Intermittently flashing lamp	15
154. Magnet-controlled intermittently flashing lamp	15
155. Flashing LED	15
156. Magnet-controlled flashing LED	15
157. Button switch-controlled flashing LED	15
158. Acousto-optic buzz police wagon sound	15
159. Acousto-optic buzz sound of machine gun	15
160. Acousto-optic buzz sound of fire engine	15
161. Acousto-optic buzz sound of ambulance	15
162. Acousto-optic buzz sound of Buddha laugh	15
163. Magnet-controlled acousto-optic buzz sound of police wagon	15
164. Magnet-controlled acousto-optic buzz sound of machine gun	15
165. Magnet-controlled acousto-optic buzz sound of fire engine	15
166. Magnet-controlled acousto-optic buzz sound of ambulance	15
167. Magnet-controlled acousto-optic buzz sound of Buddha laugh	15
168. Light-controlled buzz volume sound of police wagon	15
169. Light-controlled buzz volume sound of machine gun	15
170. Light-controlled buzz volume sound of fire engine	15
171. Light-controlled buzz volume sound of ambulance	15
172. Light-controlled buzz volume sound of Buddha laugh	15
173. Red light motor-controlled sound of patrol wagon	16
174. Red motor-controlled sound of machine gun	16
175. Motor-controlled sound of fire engine	16
176. Red light motor-controlled sound of ambulance	16
177. Red light motor-controlled sound of Buddha laugh	16
178. Hand-controlled space war	16
179. Magnet-controlled space war	16
180. Light-controlled space war	16
181. Touch-controlled space war	16
182. Water-controlled space war	16
183. Hand-controlled flashing LED	16
184. Magnet-controlled flashing LED	16
185. Light-controlled flashing LED	16
186. Touch-controlled flashing LED	16
187. Rain-controlled flashing LED	16
188. Hand-controlled flashing lamp	16
189. Magnet-controlled flashing lamp	16
190. Light-controlled flashing lamp	16

Sequence number and experiments	Page number
191. Touch-controlled flashing lamp	16
192. Rain-controlled flashing lamp	16
193. Touch-controlled acousto-optic space war	17
194. Magnet-controlled acousto-optic space war	17
195. Water-controlled acousto-optic space war	17
196. Light-controlled acousto-optic space war	17
197. Hand-controlled acousto-optic space war	17
198. Light-controlled buzz acousto-optic space war	17
199. Magnet-controlled buzz acousto-optic space war	17
200. Water-controlled buzz acousto-optic space war	17
201. Hand-controlled buzz acousto-optic space war	17
202. Touch-controlled buzz acousto-optic space war	17
203. Magnet-controlled buzz space war	17
204. Light-controlled buzz space war	17
205. Hand-controlled buzz space war	17
206. Touch-controlled buzz space war	17
207. Magnet-controlled motor activated acousto-optic space war	18
208. Light-controlled motor activated acousto-optic space war	18
209. Hand-controlled motor activated acousto-optic space war	18
210. Touch-controlled motor activated acousto-optic space war	18
211. Magnet-controlled buzz space war with light	18
212. Light-controlled buzz space war with light	18
213. Hand-controlled buzz space war with light	18
214. Touch-controlled buzz space war with light	18
215. Amplification effect of NPN triode	18
216. Amplifying effect of PNP triode	18
217. Single variable luminosity lamp(1)	19
218. Single variable speed fan(1)	19
219. Magnet-controlled single variable luminosity lamp(1)	19
220. Magnet-controlled single variable speed fan(1)	19
221. Single variable luminosity lamp(2)	19
222. Single variable speed fan(2)	19
223. Magnet-controlled single variable luminosity lamp(2)	19
224. Magnet-controlled single variable speed fan(2)	19
225. Single variable luminosity lamp(3)	19
226. Single variable speed fan(3)	19
227. Magnet-controlled single variable luminosity lamp(3)	19
228. Magnet-controlled single variable speed fan(3)	19
229. Single variable luminosity lamp(4)	19

Sequence number and experiments	Page number
230. Single variable speed fan(4)	19
231. Magnet-controlled single variable luminosity lamp(4)	19
232. Magnet-controlled single variable speed fan(4)	19
233. Touch switch-controlled LED	20
234. Touch -controlled lamp	20
235. Light-controlled lamp	20
236. Light-controlled LED	20
237. Touch -controlled fan	20
238. Light-controlled fan	20
239. Combined-transistors variable luminosity lamp(1)	20
240. Combined-transistors variable speed fan(1)	20
241. Combined-transistors variable luminosity lamp(2)	20
242. Combined-transistors variable speed fan(2)	20
243. Simple automatic street lamp(1)	20
244. Simple automatic electric fan(1)	20
245. Simple light-controlled lamp(1)	20
246. Simple light-controlled electric fan(1)	20
247. Simple electric street lamp(2)	21
248. Simple automatic electric fan(2)	21
249. Simple light-controlled lamp(2)	21
250. Simple light-controlled electric fan(2)	21
251. Light-activated LED(1)	21
252. Light-activated LED(2)	21
253. Dark-activated LED(1)	21
254. Dark-activated LED(2)	21
255. LED of adjustable luminosity	21
256. Time-delay lamp(1)	21
257. Time-delay lamp(2)	21
258. Timed beside lamp(1)	22
259. Simple timed electric fan(1)	22
260. Timed beside lamp(2)	22
261. Simple timed electric fan(2)	22
262. Unresponsive lamp(1)	22
263. Unresponsive lamp(2)	22
264. Adjustable timed lamp(1)	23
265. Adjustable timed lamp(2)	23
266. Adjustable Timed lamp(1)	23
267. Adjustable timed fan(1)	23
268. Adjustable Timed lamp(2)	23

Sequence number and experiments	Page number
269. Adjustable timed fan(2)	23
270. Single anti-theft alarm lamp(1)	23
271. Single anti-theft alarm lamp(2)	23
272. Combined-transistors anti-theft alarm lamp(1)	24
273. Combined-transistors anti-theft alarm lamp(2)	24
274. Sound-controlled flashing color lamp	24
275. Moter-controlled flashing color lamp	24
276. Blow out the lamp	24
277. Lamp that goes out but lights again(1)	24
278. Instant stop lamp(1)	24
279. Instant stop electric fan(1)	24
280. Lamp that goes out but lights again(2)	24
281. Instant stop lamp(2)	25
282. Instant stop electric fan(2)	25
283. Electrical-optic gun	25
284. One flashing Lamp	25
285. Lazy fan	25
286. Simple way of electric charging and discharging	25
287. Electronic mail box reminder	25
288. The charging and discharging of capacitor	25
289. Power stored lamp	26
290. Automatic navigation lamp	26
291. Simple metronome	26
292. Flashing bulb	26
293. Soft music	26
294. Hand-controlled soft music	26
295. Magnet-controlled soft music	26
296. Sound-controlled time-delay soft music	26
297. Motor-activated time-delay soft music	26
298. Light-controlled soft music	26
299. Water-controlled soft music	26
300. Magnet-controlled time-delay soft music	26
301. Hand-controlled time-delay soft music	26
302. Acousto-optic buzzer music doorbell	27
303. Hand-controlled sound of music give outted by an acousto-optic buzzer	27
304. Magnet-controlled sound of music give outted by an acousto-optic buzzer	27
305. Light-controlled sound of music give outted by an acousto-optic buzzer	27
306. Water-controlled sound of music give outted by an acousto-optic buzzer	27
307. Motor-controlled sound of music give outted by an acousto-optic buzzer	27

Sequence number and experiments	Page number
with a time delay-----	27
308. Hand-controlled sound of music give outted by an acousto-optic buzzer with a time delay-----	27
309. Magnet-controlled sound of music give outted by an acousto-optic buzzer with a time delay-----	27
310. Hand-controlled intermittent acousto-optic buzzer doorbell-----	27
311. Magnet-controlled intermittent acousto-optic buzz doorbell-----	27
312. Magnet-controlled intermittent soft music-----	27
313. Hand-controlled intermittent soft music-----	27
314. Hand-controlled intermittent music doorbell-----	28
315. Magnet-controlled intermittent music doorbell-----	28
316. Color lamp doorbell-----	28
317. Light-controlled color lamp doorbell-----	28
318. Water-controlled color lamp doorbell-----	28
319. Magnet-controlled color lamp doorbell-----	28
320. Hand-controlled color lamp doorbell-----	28
321. Sound-controlled time-delay color lamp doorbell-----	28
322. Motor-activated time-delay color lamp doorbell-----	28
323. Magnet-controlled time-delay color lamp doorbell-----	28
324. Hand-controlled time-delay color lamp doorbell-----	28
325. High-sensitivity sound-controlled music doorbell-----	28
326. High-sensitivity sound-controlled lamp with a time delay-----	28
327. High-sensitivity sound-controlled LED with time delay-----	28
328. High-sensitivity sound-controlled doorbell with color lamp-----	29
329. High-sensitivity sound-controlled delay double flashing lamp-----	29
330. High-sensitivity sound-controlled acousto-optic doorbell-----	29
331. High-sensitivity sound-controlled soft music-----	29
332. Dawn light-controlled sound of music-----	29
333. Dawn light-controlled flashing lamp-----	29
334. Dawn light-controlled flashing LED-----	29
335. Dawn light-controlled sound of music motor-----	29
336. Dawn light-controlled double flashing lamps-----	29
337. Dawn light-controlled sound of acousto-optic doorbell-----	29
338. Dawn light-controlled sound of color lamp doorbell-----	29
339. Dawn light-controlled light music-----	29
340. Darkness-controlled light music-----	30
341. Darkness reminder-----	30
342. Darkness-controlled LED-----	30
343. Darkness-controlled music of motor-----	30

Sequence number and experiments	Page number
344. Darkness-controlled sound of buzz music motor-----	30
345. Darkness-controlled sound of color lamp doorbell-----	30
346. Darkness-controlled of double color flashing lamp-----	30
347. Red-green flashing lamp-----	30
348. Magnet-controlled red-green flashing lamp-----	30
349. Light-controlled red-green flashing lamp-----	30
350. Water-controlled red-green flashing lamp-----	30
351. Hand-controlled red-green flashing lamp-----	30
352. Sound-controlled red-green flashing lamp with time delay-----	30
353. Motor-controlled red-green flashing lamp with time delay-----	30
354. Magnet-controlled red-green flashing lamp with time delay-----	31
355. Hand-controlled red-green lamp with time delay-----	31
356. Sound & doorbell with medium pitch sound-----	31
357. Magnet-controlled acousto-optic doorbell with medium pitch sound-----	31
358. Light-controlled acousto-optic doorbell with medium pitch sound-----	31
359. Water-controlled acousto-optic doorbell with medium pitch sound-----	31
360. Hand-controlled acousto-optic doorbell with medium pitch sound-----	31
361. Hand-controlled acousto-optic doorbell with medium pitch sound and time delay-----	31
362. Magnet-controlled acousto-optic doorbell with medium pitch sound and time delay-----	31
363. Doorbell with color lamp and high pitch sound-----	32
364. Light-controlled doorbell with color lamp and high pitch sound-----	32
365. Water-controlled doorbell with color lamp and high pitch sound-----	32
366. Hand-controlled doorbell with color lamp and high pitch sound-----	32
367. Magnet-controlled doorbell with color lamp and high pitch sound-----	32
368. Sound-controlled doorbell with color lamp and high pitch sound-----	32
369. Motor-controlled doorbell with color lamp and high pitch sound-----	32
370. Magnet-controlled time-delay doorbell with color lamp and high pitch sound-----	32
371. Hand-controlled time-delay doorbell with color lamp and high pitch sound-----	32
372. Hand-controlled intermittent acousto-optic doorbell with medium pitch sound-----	32
373. Magnet-controlled intermittent acousto-optic doorbell with medium pitch sound-----	33
374. Hand-controlled intermittent doorbell with color lamp and high pitch sound-----	33
375. Magnet-controlled intermittent doorbell with color lamp and high pitch	33

Sequence number and experiments	Page number
sound-----	33
376. High-sensitivity sound-controlled red-green double color lamp-----	33
377. High-sensitivity sound-controlled acousto-optic doorbell with medium pitch sound-----	33
378. High-sensitivity sound-controlled doorbell with high pitch sound-----	33
379. Light-activated red-green color lamp-----	33
380. Light-activated acousto-optic doorbell with medium pitch sound-----	33
381. Daybreak-activated doorbell with high pitch sound-----	33
382. Sad birthday blessing-----	34
383. Lazy music-----	34
384. Motor birthday candle-----	34
385. Day break-activated lazy alarm clock-----	34
386. Gentle blessing at dark-----	34
387. Red light warning sound of police wagon-----	34
388. Red light warning sound of machine gun-----	34
389. Red light warning sound of fire engine-----	34
390. Red light warning sound of ambulance-----	34
391. Red light warning sound of Buddha laugh-----	34
392. Magnet-controlled red light warning sound of machine gun-----	34
393. Magnet-controlled red light warning sound of machine gun-----	34
394. Magnet-controlled red light warning sound of fire engine-----	34
395. Magnet-controlled red light warning sound of ambulance-----	34
396. Magnet-controlled red light warning sound of Buddha laugh-----	34
397. Flashing red-green double alarm lamps-----	35
398. Magnet-controlled flashing red-green double alarm lamps-----	35
399. Acousto-optic low sound of police wagon-----	35
400. Acousto-optic low pitch sound of machine gun-----	35
401. Acousto-optic low pitch sound of fire engine-----	35
402. Acousto-optic low pitch sound of ambulance-----	35
403. Acousto-optic low pitch sound of Buddha laugh-----	35
404. Magnet-controlled acousto-optic low pitch sound of police wagon-----	35
405. Magnet-controlled acousto-optic low pitch sound of machine gun-----	35
406. Magnet-controlled acousto-optic low pitch sound of fire engine-----	35
407. Magnet-controlled acousto-optic low pitch sound of ambulance-----	35
408. Magnet-controlled acousto-optic low pitch sound of Buddha laugh-----	35
409. Acousto-optic medium pitch sound of police wagon-----	35
410. Acousto-optic medium pitch sound of machine gun-----	35
411. Acousto-optic medium pitch sound of fire engine-----	35
412. Acousto-optic medium pitch sound of ambulance-----	35

Sequence number and experiments	Page number
413. Acousto-optic medium pitch sound of Buddha laugh-----	35
414. Magnet-controlled acousto-optic medium pitch sound of police wagon-----	35
415. Magnet-controlled acousto-optic medium pitch sound of machine gun-----	35
416. Magnet-controlled acousto-optic medium pitch sound of fire engine-----	35
417. Magnet-controlled acousto-optic medium pitch sound of ambulance-----	35
418. Magnet-controlled acousto-optic medium pitch sound of Buddha laugh-----	35
419. Amplified sound of police wagon-----	36
420. Amplified sound of machine gun-----	36
421. Amplified sound of fire engine-----	36
422. Amplified sound of ambulance-----	36
423. Amplified Sound of Buddha laugh-----	36
424. Amplified light sound of machine gun-----	36
425. Amplified sound of heavy machine gun-----	36
426. Amplified sound of clash-----	36
427. Magnet-controlled amplified sound of police wagon-----	36
428. Magnet-controlled amplified sound of machine gun-----	36
429. Magnet-controlled amplified sound of fire engine-----	36
430. Magnet-controlled amplified sound of ambulance-----	36
431. Magnet-controlled amplified Sound of Buddha laugh-----	36
432. Magnet-controlled amplified sound of light machine gun-----	36
433. Magnet-controlled amplified sound of heavy machine gun-----	36
434. Magnet-controlled amplified sound of whomp-----	36
435. Amplified sound of game machine-----	36
436. Amplified slow sound of machine gun-----	36
437. Magnet-controlled amplified sound of game machine-----	36
438. Magnet-controlled amplified slow sound of machine gun-----	36
439. Dark activated alarming sound of police wagon-----	36
440. Dark activated alarming sound of machine gun-----	36
441. Dark activated alarming sound of fire engine-----	36
442. Sound of ambulance that alarms at dark-----	36
443. Dark activated alarming sound of Buddha laugh-----	36
444. Sound of police wagon that fears the magnet-----	36
445. Sound of machine gun that fears the magnet-----	36
446. Sound of fire engine that fears the magnet-----	36
447. Sound of ambulance that fears the magnet-----	36
448. Sound of Buddha laugh that fears the magnet-----	36
449. Dawn light-activated alarming sound of police wagon-----	37
450. Dawn light-activated alarming sound of machine gun-----	37
451. Dawn light-activated alarming sound of fire engine-----	37

Sequence number and experiments	Page number
452. Dawn light-activated alarming sound of ambulance	37
453. Dawn light-activated alarming sound of Buddha laugh	37
454. Combined-transistors touch-controlled sound of police wagon	37
455. Combined-transistors touch-controlled sound of machine gun	37
456. Combined-transistors touch-controlled sound of fire engine	37
457. Combined-transistors touch-controlled sound of ambulance	37
458. Combined-transistors touch-controlled sound of Buddha laugh	37
459. Anti-theft sound of police wagon activated by wire breaking(1)	37
460. Anti-theft sound of machine gun activated by wire breaking(1)	37
461. Anti-theft sound of fire engine activated by wire breaking(1)	37
462. Anti-theft sound of ambulance activated by wire breaking(1)	37
463. Anti-theft sound of Buddha laugh activated by wire breaking(1)	37
464. Anti-theft alarming flash LED activated by wire breaking(1)	37
465. Anti-theft sound of police wagon activated by wire breaking(2)	38
466. Anti-theft sound of machine gun activated by wire breaking(2)	38
467. Anti-theft sound of fire engine activated by wire breaking(2)	38
468. Anti-theft sound of ambulance activated by wire breaking(2)	38
469. Anti-theft sound of Buddha laugh activated by wire breaking(2)	38
470. Anti-theft alarming flash LED activated by wire breaking(2)	38
471. Light-controlled anti-theft alarm(1)	38
472. Light-controlled anti-theft alarming lamp(1)	38
473. Magnet-controlled anti-theft alarm(1)	38
474. Magnet-controlled anti-theft alarm lamp(1)	38
475. Light-controlled anti-theft alarm(2)	38
476. Light-controlled anti-theft alarm lamp(2)	38
477. Magnet-controlled anti-theft alarm(2)	38
478. Magnet-controlled anti-theft alarm lamp(2)	38
479. Alarming sound of patrol wagon with time delay	38
480. Alarming sound of machinegun with time delay	38
481. Alarming sound of fire machine with time delay	38
482. Alarming sound of ambulance with time delay	38
483. Alarming sound of Buddha laugh with time delay	38
484. Magnet-controlled sound of patrol wagon with time delay	38
485. Magnet-controlled sound of machinegun with time delay	38
486. Magnet-controlled sound of fire machine with time delay	38
487. Magnet-controlled sound of ambulance with time delay	38
488. Magnet-controlled sound of Buddha laugh with time delay	38
489. Funny police wagon sound of game machine	39
490. Magnet-controlled funny police wagon sound of game machine	39

Sequence number and experiments	Page number
491. Urging device for lamp switching off	39
492. Lighting bulb monitor	39
493. Touch-controlled acousto-optic space war with low pitch sound	39
494. Magnet-controlled acousto-optic space war with low pitch sound	39
495. Light-controlled acousto-optic space war with low pitch sound	39
496. Hand-controlled acousto-optic space war with low pitch sound	39
497. Water-controlled acousto-optic space war with low pitch sound	39
498. Magnet-controlled space war with light and medium pitch sound	40
499. Light-controlled space war with light and medium pitch sound	40
500. Hand-controlled space war with light and medium pitch sound	40
501. Touch-controlled space war with light and medium pitch sound	40
502. Water-controlled acousto-optic space war with medium pitch sound	40
503. Hand-controlled amplified space war	40
504. Magnet-controlled amplified space war	40
505. Light-controlled amplified space war	40
506. Touch-controlled amplified space war	40
507. Water-controlled amplified space war	40
508. Hand-controlled space dogfight	40
509. Magnet-controlled space dogfight	40
510. Touch-controlled space dogfight	40
511. Water-controlled space dogfight	40
512. Light-controlled space dogfight	40
513. Blowing space war in high volume	41
514. Flashing lamp that may be lighted by air blowing	41
515. LED that may be lighted by air blowing	41
516. Combined-transistors touch-controlled space war	41
517. Combined-transistors water-controlled space war	41
518. Combined-transistors magnet-controlled space war	41
519. Time-delay space war	41
520. Magnet-controlled time-delay space war	41
521. Darkness-controlled sound of space war	41
522. Dawn light-controlled sound of space war	41
523. Anti-theft sound of tangled space war activated by wire breaking(1)	41
524. Light-controlled anti-theft sound of tangled space war(1)	41
525. Magnet-controlled anti-theft sound of tangled space war(1)	42
526. Anti-theft sound of tangled space war activated by wire breaking(2)	42
527. Light-controlled anti-theft sound of tangled space war(2)	42
528. Magnet-controlled anti-theft sound of tangled space war(2)	42
529. Bidirectional doorbell that can transmit information	42

Sequence number and experiments	Page number
530. Magnet-controlled bidirectional music doorbell-----	42
531. Bidirectional low volume doorbell that can transmit information-----	42
532. Magnet-controlled bidirectional low volume doorbell-----	42
533. Bidirectional medium volume acousto-optic doorbell that can transmit information-----	42
534. Magnet-controlled bidirectional medium volume acousto-optic doorbell-----	42
535. Bidirectional high volume doorbell that can transmit information-----	42
536. Magnet-controlled bidirectional high volume doorbell-----	42
537. Reminder for closing the door of a refrigerator -----	43
538. Reminding lamp for closing the door of a refrigerator-----	43
539. Sound-controlled reverberant sound of music police wagon-----	43
540. Sound-controlled reverberant sound of music machine gun-----	43
541. Sound-controlled reverberant sound of music ambulance-----	43
542. Sound-controlled reverberant sound of music fire engine -----	43
543. Sound-controlled reverberant sound of music Buddha laugh -----	43
544. Motor-controlled reverberant sound of music police wagon-----	43
545. Motor-controlled reverberant sound of music machine gun-----	43
546. Motor-controlled reverberant sound of music ambulance-----	43
547. Motor-controlled reverberant sound of music fire engine -----	43
548. Motor-controlled reverberant sound of music Buddha laugh -----	43
549. Light-controlled reverberant sound of music police wagon -----	44
550. Light-controlled reverberant sound of music machine gun -----	44
551. Light-controlled reverberant sound of music ambulance -----	44
552. Light-controlled reverberant sound of music fire engine -----	44
553. Light-controlled reverberant sound of music Buddha laugh -----	44
554. Rain-controlled reverberant sound of music police wagon-----	44
555. Rain-controlled reverberant sound of music machine gun-----	44
556. Rain-controlled reverberant sound of music ambulance-----	44
557. Rain-controlled reverberant sound of music fire engine -----	44
558. Rain-controlled reverberant sound of music Buddha laugh -----	44
559. Magnet-controlled reverberant sound of music police wagon -----	44
560. Magnet-controlled reverberant sound of music machine gun -----	44
561. Magnet-controlled reverberant sound of music ambulance -----	44
562. Magnet-controlled reverberant sound of music fire engine-----	44
563. Magnet-controlled reverberant sound of music Buddha laugh-----	44
564. Magnet-controlled time-delay reverberant sound of music police wagon -----	44
565. Magnet-controlled time-delay reverberant sound of music machine gun-----	44
566. Magnet-controlled time-delay reverberant sound of music ambulance -----	44
567. Magnet-controlled time-delay reverberant sound of music fire engine-----	44

Sequence number and experiments	Page number
568. Magnet-controlled time-delay reverberant sound of music Buddha laugh-----	44
569. Hand-controlled time-delay reverberant sound of music police wagon-----	44
570. Hand-controlled time-delay reverberant sound of music machine gun-----	44
571. Hand-controlled time-delay reverberant sound of music fire engine -----	44
572. Hand-controlled time-delay reverberant sound of music ambulance -----	44
573. Hand-controlled time-delay reverberant sound of music Buddha laugh-----	44
574. Magnet-controlled flashing LED-----	45
575. Light-controlled flashing LED-----	45
576. Water-controlled flashing LED-----	45
577. Hand-controlled flashing LED-----	45
578. Sound-controlled flashing LED -----	45
579. Sound-controlled flashing LED with time delay-----	45
580. Hand-controlled flashing LED with time delay-----	45
581. Magnet-controlled flashing LED with time delay-----	45
582. Automatic tangled space war-----	45
583. Space flashing lamp-----	45
584. Magnet-controlled space flashing lamp-----	45
585. Magnet-controlled space dogfight-----	45
586. Touch-controlled reverberant utensil of space police wagon -----	46
587. Touch-controlled reverberant utensil of space machine gun -----	46
588. Touch-controlled reverberant utensil of space fire engine -----	46
589. Touch-controlled reverberant utensil of space ambulance -----	46
590. Touch-controlled reverberant utensil of space Buddha laugh -----	46
591. Rain-controlled reverberant utensil of space police wagon -----	46
592. Rain-controlled reverberant utensil of space machine gun -----	46
593. Rain-controlled reverberant utensil of space fire engine-----	46
594. Rain-controlled reverberant utensil of space ambulance-----	46
595. Rain-controlled reverberant utensil of space Buddha laugh-----	46
596. Hand-controlled reverberant utensil of space police wagon -----	46
597. Hand-controlled reverberant utensil of space machine gun -----	46
598. Hand-controlled reverberant utensil of space fire engine-----	46
599. Hand-controlled reverberant utensil of space ambulance -----	46
600. Hand-controlled reverberant utensil of space Buddha laugh -----	46
601. Magnet-controlled reverberant utensil of space police wagon-----	46
602. Magnet-controlled reverberant utensil of space machine gun -----	46
603. Magnet-controlled reverberant utensil of space fire engine-----	46
604. Light-controlled reverberant utensil of space ambulance -----	46
605. Light-controlled reverberant utensil of space Buddha laugh -----	46

Sequence number and experiments	Page number
606. Light-controlled reverberant utensil of space police wagon	46
607. Light-controlled reverberant utensil of space machine gun	46
608. Light-controlled reverberant utensil of space fire engine	46
609. Light-controlled reverberant utensil of space ambulance	46
610. Light-controlled space Sound of Buddha laugh reverberant utensil	46
611. Light-controlled reverberant utensil of space music	47
612. Touch-controlled reverberant utensil of space music	47
613. Water-controlled reverberant utensil of space music	47
614. Hand-controlled reverberant utensil of space music	47
615. Magnet-controlled reverberant utensil of space music	47
616. Sound-controlled time-delay space war	47
617. Motor-controlled time-delay space war	47
618. Sound-controlled time-delay space flashing lamp	47
619. Sound-controlled time-delay space flashing LED	47
620. Motor-controlled time-delay space flashing lamp	47
621. Motor-controlled time-delay space flashing LED	47
622. Magnet-controlled time-delay space war	48
623. Magnet-controlled time-delay space flashing lamp	48
624. Magnet-controlled time-delay space flashing LED	48
625. Hand-controlled time-delay space war	48
626. Hand-controlled time-delay space flashing lamp	48
627. Hand-controlled time-delay space flashing LED	48
628. High-sensitivity sound-controlled time-delay space war	48
629. High-sensitivity sound-controlled time-delay space flashing lamp	48
630. High-sensitivity sound-controlled space flashing LED	48
631. Magnet-controlled changeable LED	48
632. Button switch-controlled variable LED	48
633. Multi-tone generator	49
634. Light-controlled electronic piano	49
635. Ticks of touching	49
636. Electronic cicada	49
637. Light-controlled electronic cicada	49
638. Sound of motor ship	49
639. Light-controlled sound of motor ship	49
640. Adjustable electronic metronome	49
641. Adjustable electronic flashing lamp	49
642. Sound of steamship	49
643. Sound of mosquito	49
644. Flash sound and light lamp	49

Sequence number and experiments	Page number
645. Sound of Suona	49
646. Water-controlled electronic metronome	49
647. Time-delay high-pitch doorbell	49
648. Time-delay metronome	49
649. Time-delay flash light	49
650. Sound of airplane	49
651. Sound of motorcycle	49
652. Sound of telegraph transmitter	49
653. Creaking of the wooden door	50
654. Magnet-controlled time-delay doorbell with high pitch sound	50
655. Magnet-controlled time-delay metronome	50
656. Magnet-controlled sound of airplane	50
657. Magnet-controlled sound of motorcycle	50
658. Magnet-controlled sound of telegraph transmitter	50
659. Magnet-controlled sound of creaking of the wooden door	50
660. Magnet-controlled anti-theft alarm with high pitch sound	50
661. High pitch sound generator	50
662. Medium pitch sound generator	50
663. Low pitch sound generator	50
664. Simple electronic metronome	50
665. Simple flashing light	50
666. Low sound of mosquito	50
667. Anti-theft alarm with high pitch sound	50
668. Anti-theft alarm with medium pitch sound	50
669. Magnet-controlled anti-theft alarm with medium pitch	50
670. Anti-theft alarm with low pitch sound	50
671. Magnet-controlled anti-theft alarm with low pitch sound	50
672. Flashing anti-theft alarm lamp	50
673. Magnet-controlled flashing anti-theft alarm lamp	50
674. Light-controlled high pitch sound generator	51
675. Touch-controlled high pitch sound generator	51
676. Light-controlled medium pitch sound generator	51
677. Touch-controlled medium pitch sound generator	51
678. Light-controlled low pitch sound generator	51
679. Touch low pitch sound generator	51
680. Light-controlled flashing alarm lamp	51
681. Magnet-controlled high pitch sound generator	51
682. Magnet-controlled medium pitch sound generator	51
683. Magnet-controlled low pitch sound generator	51

Sequence number and experiments	Page number
684. Magnet-controlled flashing lamp.....	51
685. Sound of big mosquito	51
686. Flashing lamp.....	51
687. Electronic metronome.....	51
688. High-pitch oscillator.....	51
689. Touch-controlled high-pitch oscillator.....	51
690. Light-controlled high-pitch oscillator.....	51
691. Light-controlled sound of mosquito	51
692. Touch-controlled sound of mosquito.....	51
693. Magnet-controlled sound of mosquito.....	51
694. Magnet-controlled high-pitch oscillator.....	51
695. Variable high-pitch generator.....	52
696. Light-controlled variable high-pitch.....	52
697. Touch-controlled variable high-pitch.....	52
698. Magnet-controlled variable high-pitch.....	52

Explanation for principles

1. Principle of reed switch:

Fix two iron sheets in a hermetic glass tube. Generally, the two iron sheets are disconnected. When a magnet is near the reed switch, the iron sheets are magnetized, thereby contacted with each other. Then the circuit is put through. The reed switch can be used as a magnetic switch.

2. Principle of LED:

LED is made of semiconductor material of GaP or GaAsP. It is a light-give outting device that can directly transform electrical energy into light energy. Like common diode, it is constituted by PN junction and has unidirectional conductivity. When a forward conductive voltage (generally larger than 1.8V) is applied on the points of an LED, the LED will light up. With different producing material, LED may give out light with different colors, such as red, green, etc.

3. Principle of fan and flying disc:

The blades of a fan are at an angle in design. When the blades are turning clockwise, the air in the obverse side of the fan will be pushed and move upward, forming a current of wind. This is the principle of a fan. When the blades are turning counterclockwise, the air in the inverse side of the blades will be pushed and move downward. On the contrary, the air will pose propulsion on the blades. Then the blades will fly up like a helicopter. This is the principle of a flying disc.

4. Principle of space war IC:

Memorize a prerecorded sound of space war in an IC and pack it well. To play back space sound war, you just need to connect a few electronic components.

5. Principle of water-control:

Since water is conductive, a water drop dripped on the touch plate will make the touch plate conducting, thereby enabling it to control various kinds of circuits to make change.

6. Principle of motor-control:

A motor consists of magnets and windings. When the

shaft of the motor is turned, magnetic field in the windings will change and a weak current will be generated in them. This weak current may be used to control circuits to change.

7. Principle of music IC:

Memorize a prerecorded song or several songs in the IC and pack it well, then you have a music IC. To play back, you just need to connect a few electronic components.

8. Principle of loudspeaker:

Loudspeaker is a device that can transform electrical signal into sound signal. If a current passes the sound coil in the loudspeaker, the sound coil will generate a magnetic field that changes with the variation of the audio frequency current. This variable magnetic field and the magnetic field of permanent magnet will repel or attract each other, resulting in the mechanical vibration of the sound coil, and then drive the paper cone to vibrate, thereby giving off sounds.

9. Principle of photosensitive resistor:

Photosensitive resistor is a kind of photoelectric component and is a resistor. It is made of a semiconductor material called cadmium sulphide. Such photosensitive resistor is high in photosensitivity. Its resistor varies with the intensity of light hitting at it. If the light intensity is higher, the resistance is smaller, and the current in the circuit is larger and vice versa. By using its photosensitivity, a light-controlled switch can be made.

10. Principle of buzzer:

When the piezoelectric ceramic sheet is pressed by external force or is influenced by vibration, a weak current will be generated between the two metal tabs of the piezoelectric ceramic sheet. On

11. Principle of photosensor:

The function of a photosensor is contrary to that of a loudspeaker. It is a device that can transform sound signal into electrical signal. When the diaphragm of photosensor (electrets photosensor) is influenced by sound wave and start vibrating,

the electric field between the two points of the internal capacitor will change, thereby generating hypervariable voltage signal that changes with the variation of sound wave.

12. Principle of current meter:

Place a closing coil in a permanent magnetic field. When there is current passes the coil, a magnetic field will be generated. This magnetic field and the permanent magnetic field will repel or attract each other, resulting in the deflection of the coil. Then the hand of the current meter will swing. Mark numerical value on the dial plate according to prescriptions in advance, then you can get the reading of the current meter according to the deflection angle of the hand.

13. Principle of touch-control:

Although not a good conductor, human body is conductive. When you touch the touch plate with hand, resistance across the touch plate will obviously become lower. This, plus the amplifying effect of some electronic component, can be used to control various kinds of circuits to make change.

14. Power amplification IC:

Integrate multiple amplifiers into a chip and pack it well. To form a power amplifier, you just need to connect a few electronic components. It not only has comparatively high amplification factor, but also can output large power.

15. High frequency amplification IC:

Integrate multiple high frequency amplification circuits into a chip and pack it well. To form a high frequency amplification IC, you just need to connect a few electronic components. This circuit has comparatively high receiving sensitivity and amplification factor.

16. Principle of sound-control realized by buzzer:

Structure of a buzzer is based on two metal tabs with piezoelectric ceramic material sandwiched in-between. When the buzzer is influenced by vibration, a weak current is generated between the two metal tabs because of piezoelectric effect. This weak current may be used to control circuits to make change.

17. Principle of FM IC:

Multiple circuits including receiving circuit, amplifying circuit, signal processing circuit, etc are integrated into a chip and packed well to form an FM IC. Connect some electronic components to it, then an FM receiving and processing circuit is formed. Close the switch, and there will be audio frequency signal output. When using this IC, you need to connect a power amplification circuit to amplify the output sound signal of the FM IC. Then you can hear the sound of an FM radio station.

18. Principle of capacitor:

Like a water tank that can be used to store water, a capacitor can be used to store electric charge. Connect a capacitor between the two points of a power supply and close the switch. As the capacitor has no charge, the power supply will charge up the capacitor, and there will be charging current in the circuit temporarily. Then open the switch, and put through the capacitor by a wire, you can release the electric charge stored in the capacitor. Then you can repeat the above mentioned charging operation.

19. Principle of alarm IC:

Memorize prerecorded sounds of police wagon, machine gun, fire engine, ambulance, etc. in an IC and pack it well. To play back the sounds, you just need to connect a few electronic components.

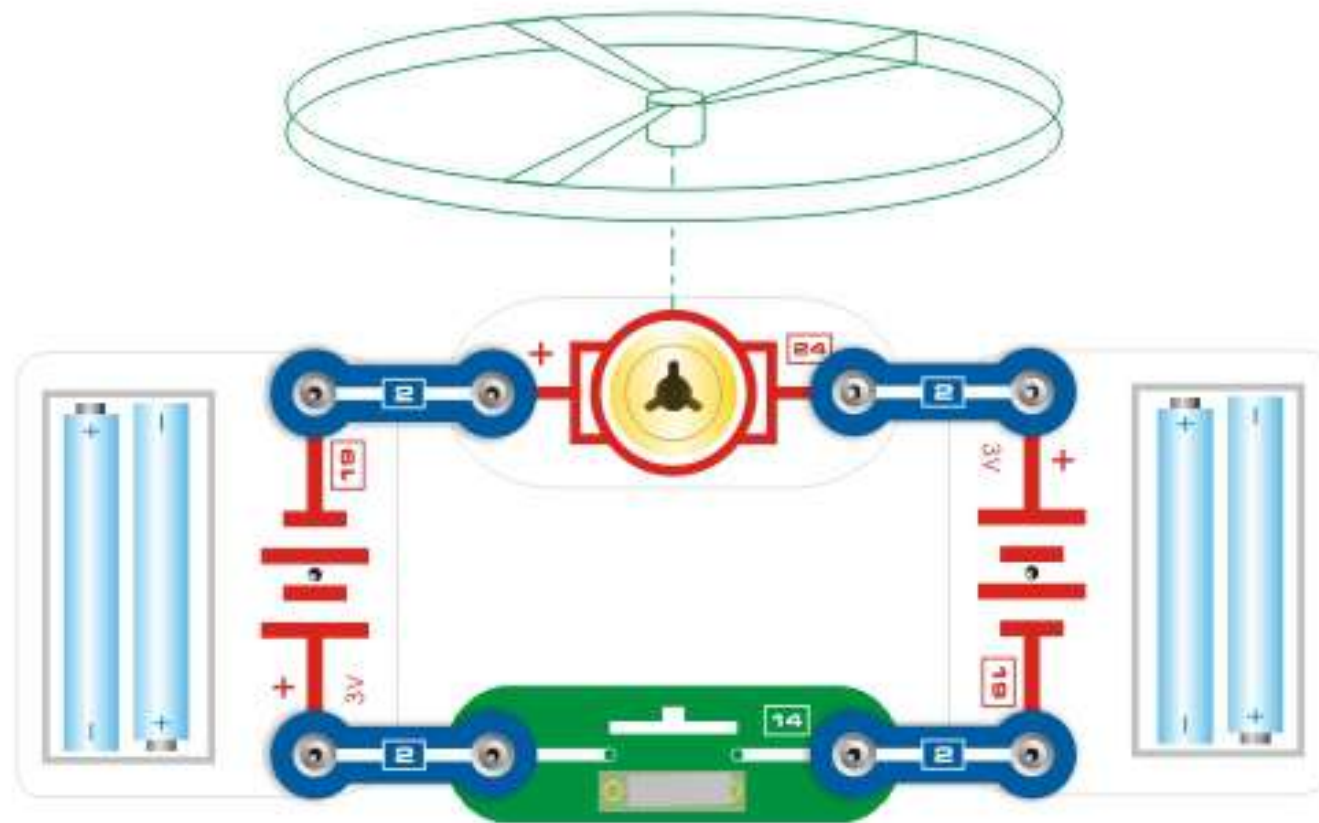

Flying saucer

Install the fan blade, press the button switch, when the motor has reached maximum rotation, release the press switch, the fan should rise and float through the air like a flying saucer.

(Warning: Moving parts. Do not touch the motor or fan during operation. Do not lean over the motor. Do not launch the fan at people, animals, or objects.)

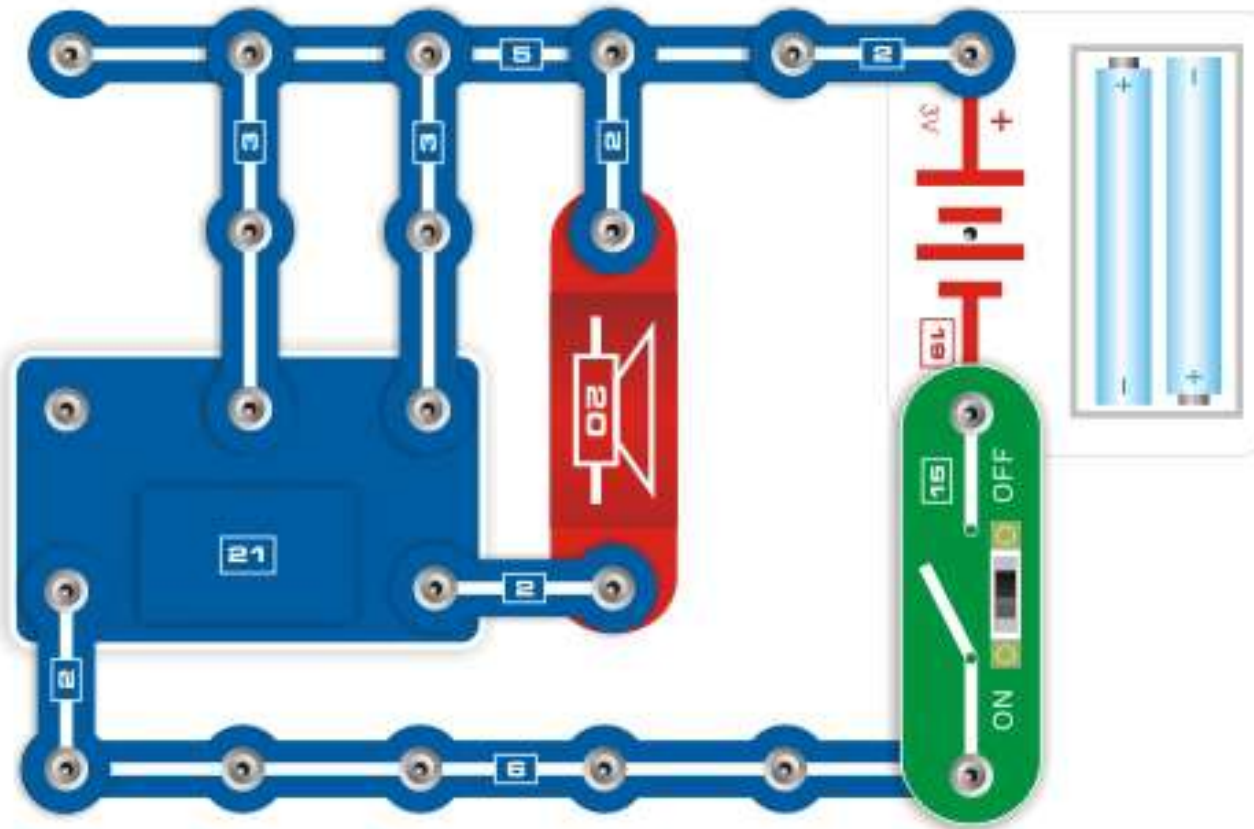

Birthday music

After build the circuit and turn on the switch, the loudspeaker will play beautiful birthday music; after playing for one time, it will start playing again after a short break and repeat it until the power is cut off.

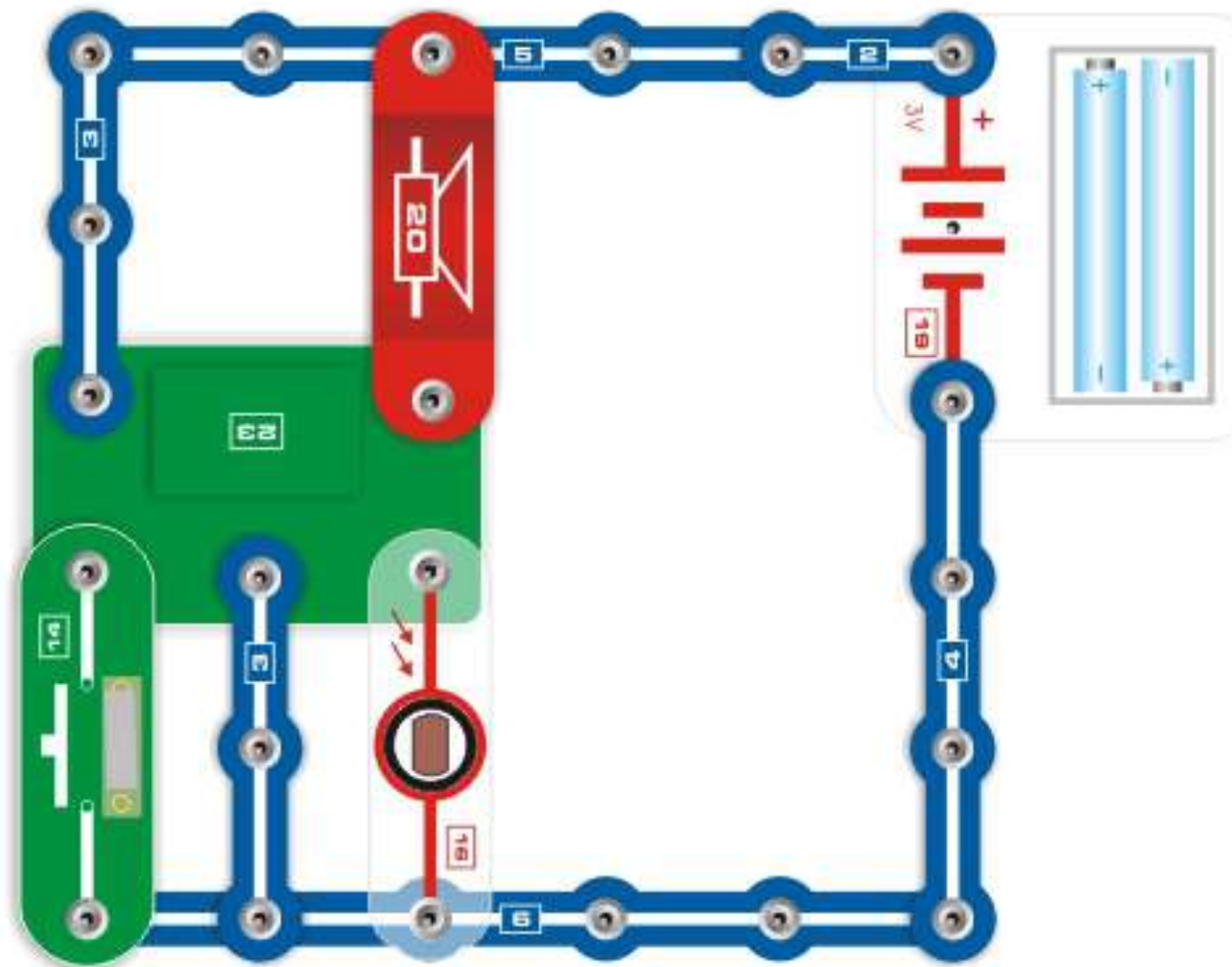

Light-controlled space war

Build the circuit, as long as there is light on the photosensitive resistor, the loudspeaker will produce the sound of space war.

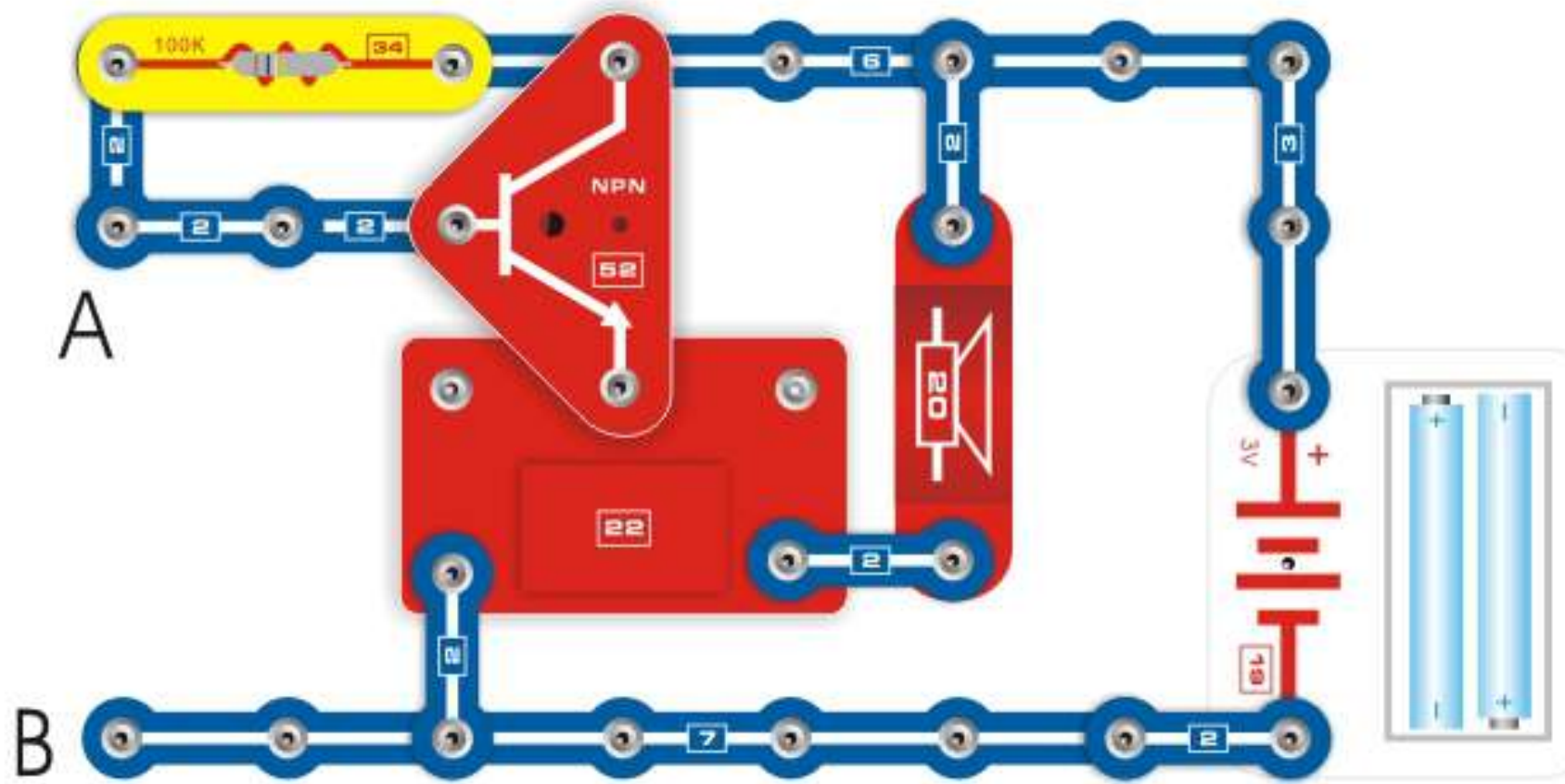

Anti-theft sound of police wagon activated by wire breaking

Built the circuit and the loudspeaker will give out alarming sound of police wagon. If points A and B are connected by a wire, the alarming sound will stop. For anti-theft, a long thin wire may be used to thread through bicycle, motorcycle, car, door, window, etc. Then connect the ends of the thin wire to points A and B. If a burglar breaks the wire, the loudspeaker will give out alarming sound of police wagon.



1. Lamp(1)

Turn on the switch, the lamp lights; turn off the switch, the lamp goes out.

2. Magnet-controlled lamp(1)

Replace the switch with a reed switch, place a magnet near the reed switch, the lamp lights, take the magnet away from the reed switch, the lamp goes out.

3. Button switch-controlled lamp(1)

Replace the switch with a button switch; press the button switch, the lamp will light; release the button switch, the lamp goes out at once.



4. Electric fan

First, install the fan blade, then turn on the switch. The fan will start to spin.

5. Magnet-controlled fan

Replace the switch with a reed switch, you will have a magnet-controlled fan.

6. Button controlled-controlled fan

Replace the switch with a button switch, and the fan can be controlled manually.



7. Flying saucer

Install the fan blade, press the button switch, when the motor has reached maximum rotation, release the press switch, the fan should rise and float through the air like a flying saucer.

(Warning: Moving parts. Do not touch the motor or fan during operation. Do not lean over the motor. Do not launch the fan at people, animals, or objects.)

8. Magnet-controlled flying saucer

Replace the button switch with a reed switch, place the magnet close to the reed switch, the motor will start spin; when the motor has

reached maximum rotation, remove the magnet rapidly and the fan should rise and float through the air like a flying saucer.

(Warning: Moving parts. Do not touch the motor or fan during operation. Do not lean over the motor. Do not launch the fan at people, animals, or objects.)

9. Direct and reverse running of motor

Reverse the connection of positive and negative poles of the motor, install the blade. Press the button switch, you will find that the motor runs in reversed direction, the fan blade can not fly up and becomes a powerful fan.

Questions: Why can a flying saucer fly in the air?



10. Series connection of lamps

Turn on the switch and the two bulbs light simultaneously, in the series circuit above, if one of the bulbs is damaged (due to broken circuit), the other bulb will not light.

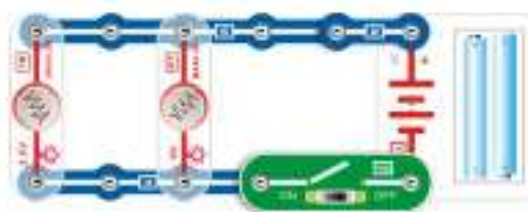

11. Parallel connection of lamps

Turn on the switch and the two bulbs light simultaneously; in the parallel circuit above, if one of the bulbs is damaged, the other can still light.



13. Parallel connection of lamp and motor

Turn on the switch, the fan rotates and the lamp lights. Turn off the switch, the fan stops and the lamp goes out.



12. Series connection of lamp and motor

Turn on the switch, the fan rotates and the lamp lights. Turn off the switch, the fan stops and the lamp goes out.



14. Basic circuit of LED

Turn on the switch, the LED lights up. The series-connected resistor serves to limit the current flowing through the LED thus to prevent damage to the LED by over-current.

15. Magnet-controlled LED

Replace the switch with a reed switch, place the magnet close to the reed switch, the LED will light at once; remove the magnet, LED goes out.

16. Button switch-controlled LED

Replace the switch with a button switch; press the button switch, the LED will light; release the button switch, the LED goes out at once.



23. Unidirectional conductivity of LED

Turn the switch, both the LED and the lamp do not light, because LED is unidirectional in conductivity, i.e. it only allows current to flow from positive pole to negative pole but not reversedly.

17. Current limiting function of resistor
Replace 100Ω resistor with 1K resistor, you may find that the brightness of led more weak then befor, because resistors series-connected to them are different in resistance. The smaller resistance, the higher current is permitted to pass. The higher resistance, the smaller current is permitted to pass. This is the current limiting function of a resistor.

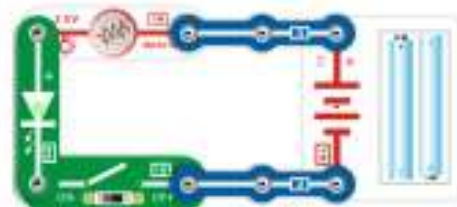

18. LED (Light Emitting Diode)

Turn on the switch, the LED lights but not the lamp. This is because LED needs only small current for itself to light up and the lamp need higher current to light up but now there is only small current in this series-connection circuit.



24. Lamp (2)

Turn on the switch, the lamp lights; turn off the switch, the lamp goes out. This circuit uses two 3V batteries to light a 6V bulb, which is different from the previous lamp circuit.

25. Magnet-controlled Lamp(2)

Replace the switch with a reed switch, place the magnet close to the reed switch, the lamp will light; remove the magnet, lamp goes out.

26. Button switch-controlled lamp(2)

Replace the switch with a button switch, press the button switch, the lamp will light; release the button switch, the lamp goes out.



19. Parallel connection of LED and lamp

Turn on the switch, LED and the lamp will light simultaneously. The series-connected resistor serves to limit the current of LED.



21. Parallel connection of LED and fan

Turn on the switch, LED lights and the fan rotates.

Question: Will the fan rotates if the LED is burnt out?

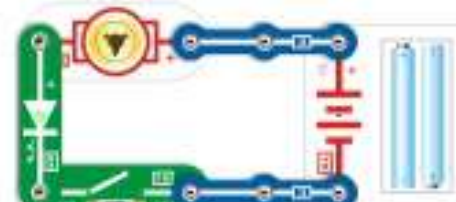

20. Series connection of fan and LED

Turn on the switch, LED will light but the motor does not rotate, because it works need large current, while only small current passes in the circuit above.

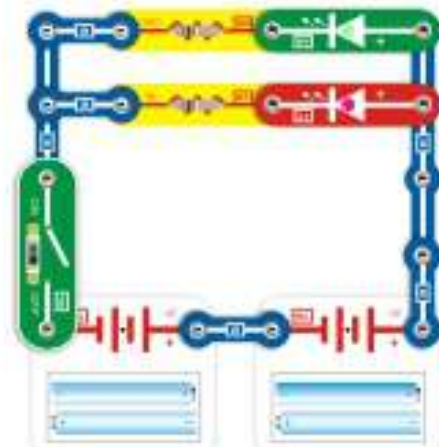

22. Red and green LED

Turn on the switch, the red LED and green LED light up simultaneously. Turn off the switch, they are goes out simultaneously.

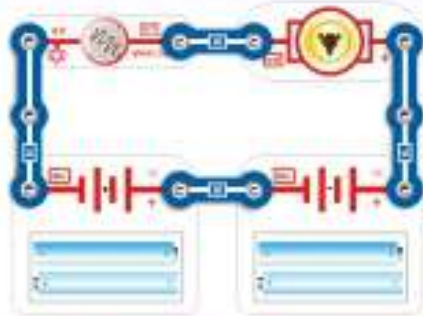

27. Series connection of batteries in the same direction

The diagram in the left indicates a series connection in the same direction and combined together produce 6V.



30. Parallel series of lamp, LED and motor (1)

After building the circuit, motor rotates and LED lights, but only the lamp does not light, because the lamp and LED are in series, and the current passing the bulb is weak. In the figure, the lamp and LED is connected in series and then both are in parallel connection with the motor; because the circuit is in both series and parallel connection, so it is called as parallel series.



28. Series connection of lamp, LED and motor

After building the circuit, only the LED lights, and the lamp and motor fail to work due to little current.



31. Parallel series of lamp, LED and motor (2)

After building the circuit, lamp and LED light, but the motor does not rotate. The principle is the same as no.30.

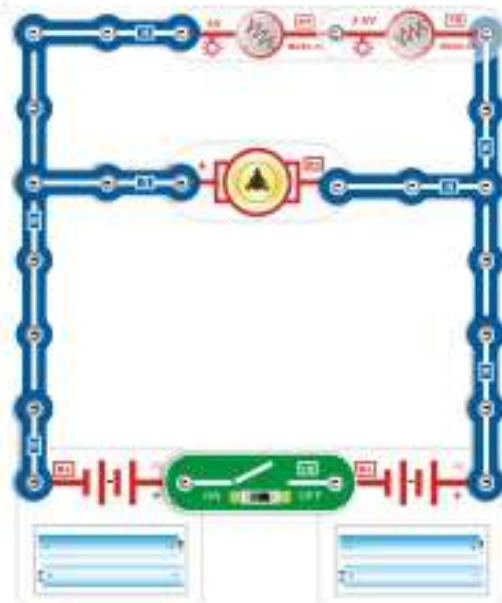

32. Parallel series of two bulbs and the motor (1)

After building the circuit, the motor rotates and two bulbs light at the same time; of which, the 2.5V bulb gives out weaker light.



29. Parallel connection of lamp, LED and motor

Turn on the switch, LED and lamp light, motor rotates simultaneously, so that three begin to work together at the same time.

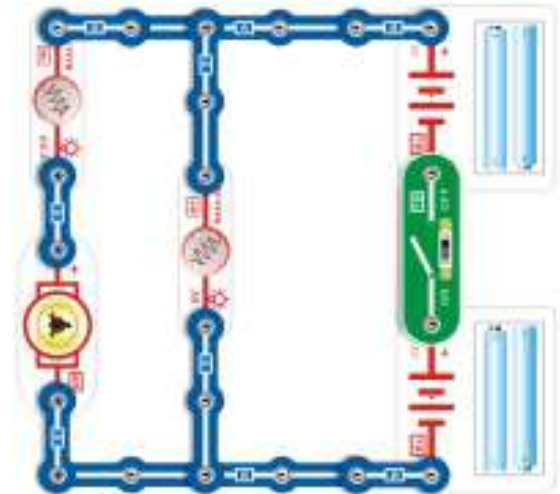

33. Parallel series of two bulbs and the motor (2)

After building the circuit, they work at the same time.

Question: Connect in reverse the motor, can the flying saucer fly?

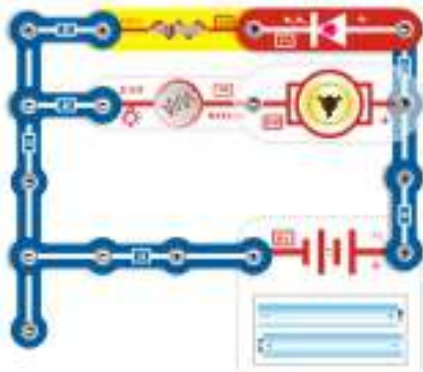

34. Parallel series of lamp, LED and motor(4)

After building the circuit, the LED and lamp lights up, and the motor rotates at the same time.



35. Parallel series of lamp, LED and motor (4)
After building the circuit, only LED lights, and the motor and the lamp do not work.

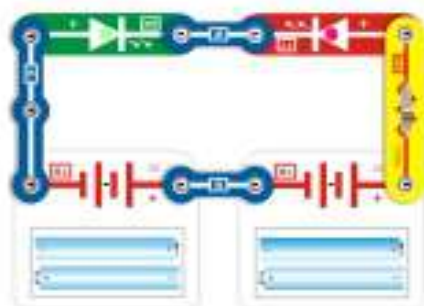

36. Series connection of LED
Turn on the switch, the two LED have the same luminosity, because all components in series connection carry the same current.

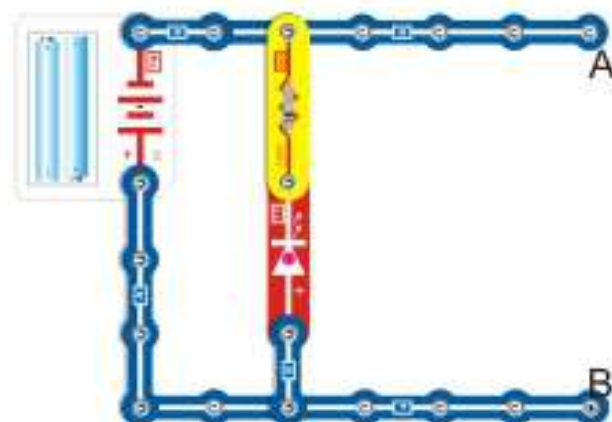

37. Power indicator

Connect the electrical appliance to the two ends of A and B, and LED is used for power indication, the greater the electric quantity is, the stronger the brightness of LED is; the smaller the electric quantity is, the weaker the brightness of LED is; when the voltage of the power decreases to the certain degree, the LED will go out.



38. Conductor tester

With this conductor tester you may identify which daily living articles are conductors and which are not. Build the circuit, then hold an object(for example a teaspoon) across the two terminals A and B. If the lamp lights, the article is a conductor, such as knife or aluminum pot. If the lamp does not light, the article is non-conductor, such as plastic or wood block.



39. Identification of battery polarity

Connect the positive pole of the battery to terminal A and the negative pole to terminal B (a 3V battery may be used for the test). In this case only the red LED lights. If the connection is reversed, only the green LED will light. With the red LED lighted, A is the battery's positive and B is negative pole.



40. Parallel series of two bulbs and the motor(3)

After building the circuit, the motor rotates and the two bulbs light at the same time, but the light is weak.

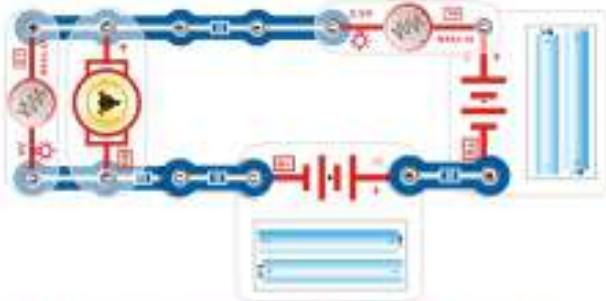

41. Parallel series of two bulbs and the motor(4)
After building the circuit, the motor rotates, the brightness of 6V bulb in parallel connection with the motor is weaker, but that of the 2.5V bulb is stronger.



42. Hand-controlled alternative lighting up of lamp and LED
Turn on the switch, only the LED lights up. Press the button switch, the led goes out and the lamp lights up at the same time.



43. Alternative lighting up of lamp and LED
Turn on the switch, only the LED lights up. When a magnet is put near the reed switch, LED goes out and the lamp lights up.



45. Alterating light
Turn on the switch, the bulb lights and the fan rotates. Press the button switch, the brightness of the bulb will change.

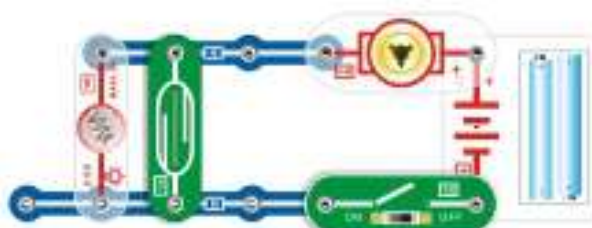

47. Variable speed electric fan
Turn on the switch, the lamp lights and the fan rotates, place the magnet close to the reed switch, the speed of fan will be variable.

46. Magnet-controlled altering light
Replace the button switch with a reed switch, and the altering light can be controlled by the magnet.

48. Button switch-controlled variable speed electric fan
Replace the reed switch with a button switch, press the button switch and the speed of the fan will be changed.

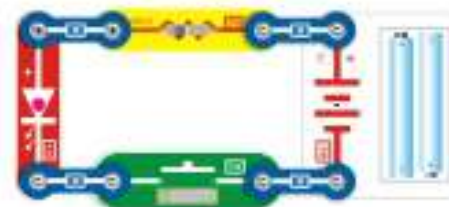

49. Simple telegraph exerciser
Press the button switch according to certain rhythm, the LED will flash. It is used for simple telegraph exercise.
Question: What will happen if replacing the 100 Ω resistor to other resistors?

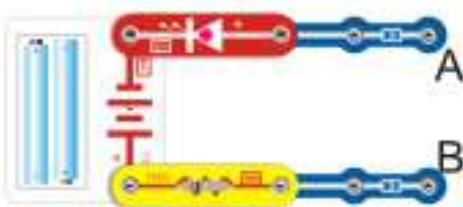

50. Lead continuity tester
This lead continuity tester can judge whether the lead with a length of several hundred or thousand meters is in good

condition. Connect the lead to the end A and B: if LED lights, the lead is in good condition; if LED does not light, the lead would be broken in some place.

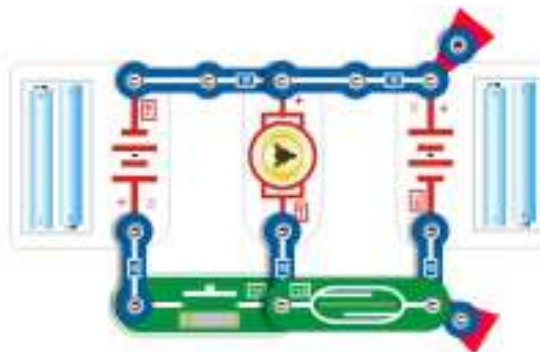

51. Positive and negative rotary-controlling circuits of motors(1)
Build the circuit and install the fan blade, press the button switch and the fan blade rotate reversely; then release the button switch and turn on the reed switch by the magnet, the fan blade rotate normally; remove the magnet and press the button switch, the fan blade rotate reversely again. ... Note: can not turn on the button switch and the reed switch at the same time; otherwise, the battery will be damaged.

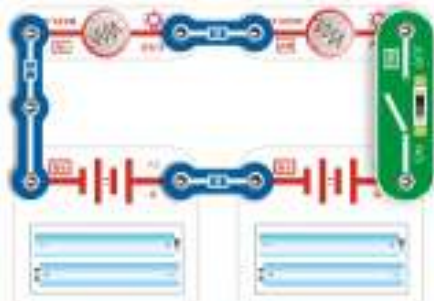

52. One switch controls two lamps in series

Turn on the switch and the two lamps light at the same time but the light of 2.5V bulb is stronger; turn off the switch, the two lamps go out at the same time.



53. One switch controls two parallel-connected lamps

Turn on the switch and the two lamps light at the same time but the light of 6V bulb is weaker; turn off the switch, the two lamps go out at the same time.

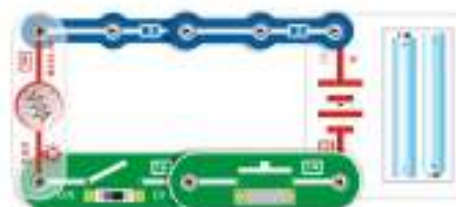

54. Two series-connected switches control one lamp

After building the circuit, the bulb can be light only when pressing the button switch and turn on the switch at the same time.

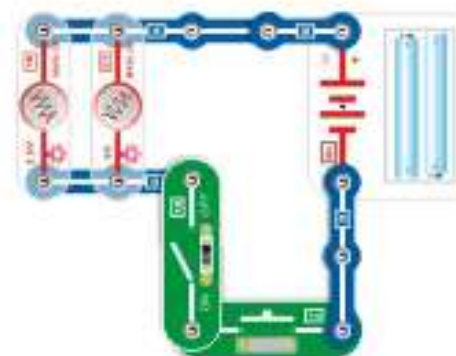

57. Two series-connected switches control two parallel-connected lamps

Two bulbs can be light only when pressing the button switch and turn on the switch at the same time, but the light of 6V bulb is weaker.

Question: How to change the circuit into two series-connected switches control three lamps?



55. Two switches in parallel control one lamp

Pressing the button switch or turn on the switch both can light the bulb; the bulb can go out only when two switches are turn off simultaneously.

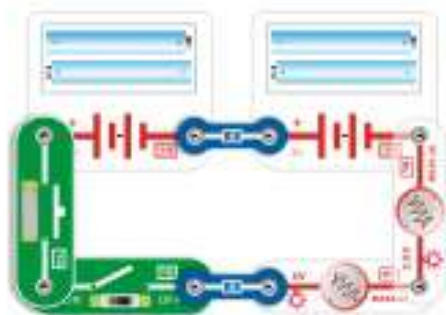

56. Two series-connected switches control two series-connected lamps

The two bulbs can be light only when pressing the button switch and turn on the switch at the same time, but the light of 2.5V bulb is stronger.

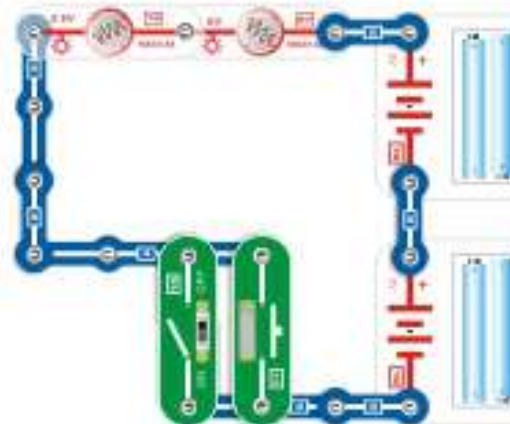

59. Two parallel-connected switches control two series-connected lamps

Pressing the button switch or turn on the switch can light the two lamps at the same time; the bulb can be go out only when two switches are turn off.

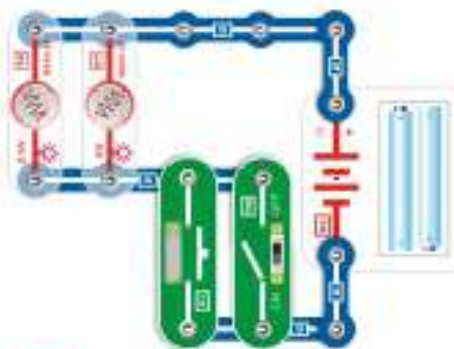

58. Two parallel-connected switches control two parallel-connected lamps

Pressing the button switch or turn on the switch can light the two lamps at the same time; the bulb can be go out only when two switches are turn off.

60. Two switches control two lamps respectively

Turn on the switch, the 6V bulb lights; press the button switch, the 2.5V bulb lights; the two bulbs work independently and do not affect each other.



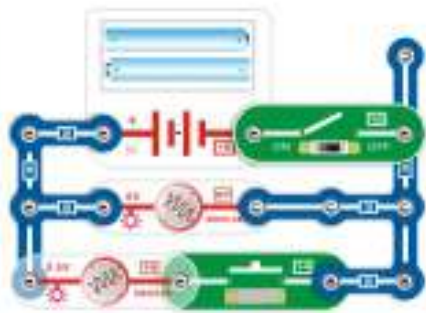

61. Two switches conduct blending in control two lamps

Turn on the switch, the 6V bulb lights; press the button switch, the 2.5V bulb lights; turn off the switch, the two lamps go out at the same time.

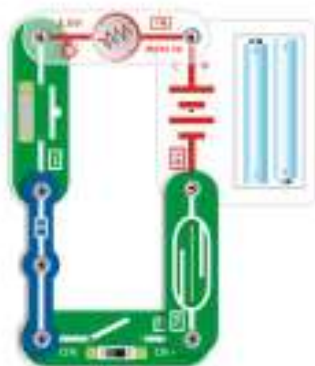

62. Three series-connected switches control one lamp

After building the circuit, the bulb can be light only when all three switches are turn on.

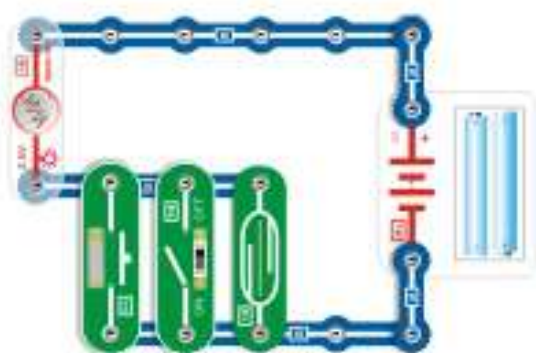

63. Three parallel-connected switches control one lamp

After building the circuit, turn on any switch can light the bulb; and the bulb can go out only when all three switches are turn off.

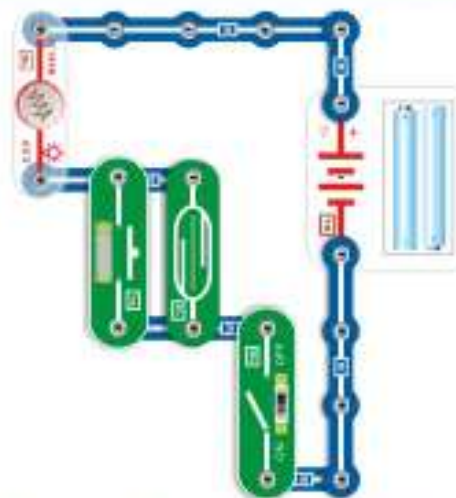

64. Three parallel series-connected switches control one lamp(1)

Turn on the switch and the bulb does not light; press the button switch or turn on the reed switch by magnet, the bulb lights; the bulb will only go out after turn off the button switch and the reed switch or turn off the general switch.

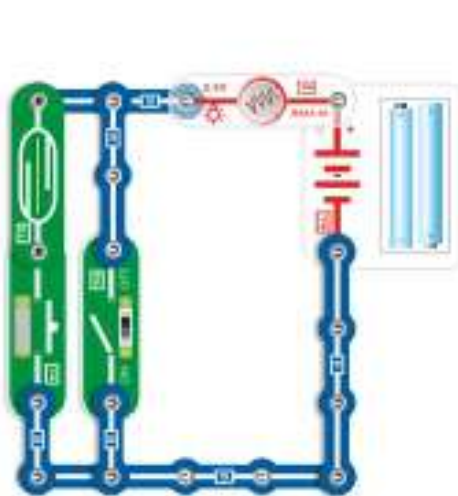

65. Three parallel-series connected switches control one lamp(2)

Turn on the switch or turn on the reed switch by magnet and the button switch at the same time can light the bulb.

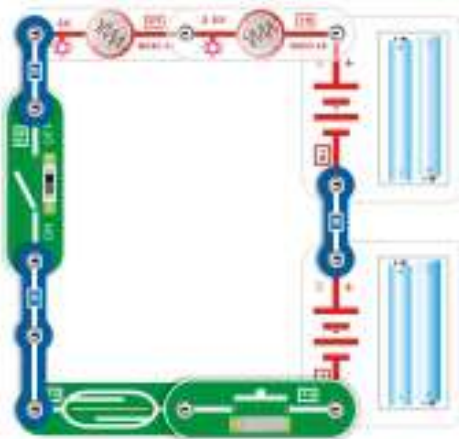

66. Three switches in series control two series-connected lamps

The two lamps can be light at the same time only when all three switches are turn on; if one lamp is damaged (due to broken circuit), the other lamp will go out.

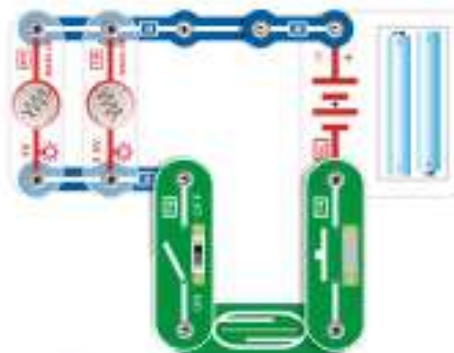

67. Three switches in series control two parallel-connected lamps

The two lamps will light at the same time only when all three switches are turn on; if one lamp is damaged, the other lamp can still light.

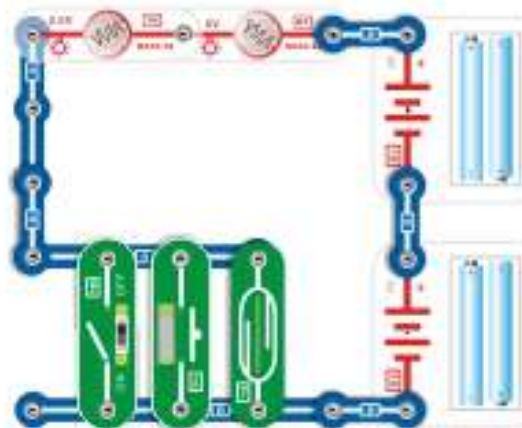

68. Three switches in parallel control two series-connected lamps

Turn on any one switch can light up the two series-connected lamps at the same time; the bulb go out only when all three switches are turn off.



69. Three switches in parallel control two parallel-connected lamps
Turn on any one switch can light the two parallel-connected lamps at the same time; the bulb can be go out only when all three switches are turn off.

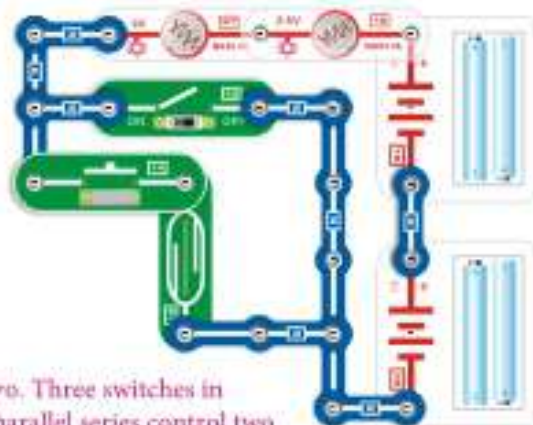

70. Three switches in parallel series control two series-connected lamps (1)
Two series-connected lamps can be light only when the switch is turn on or the button switch and reed switch are turn on at the same time.

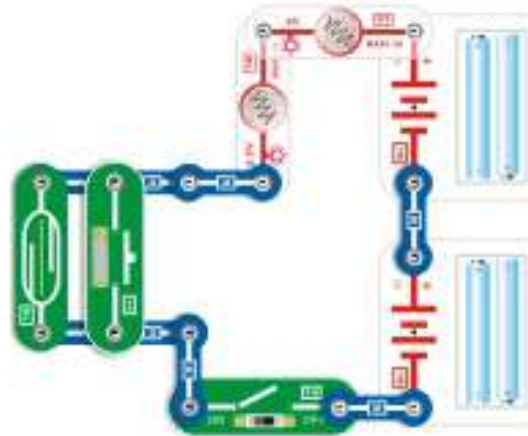

71. Three switches in parallel-series control two series-connected lamps (2)
After turn on the switch, the bulb will light if turn on reed switch or pressing the button switch; the bulb will only go out after turn off the button switch and the reed switch or turn off the general switch.

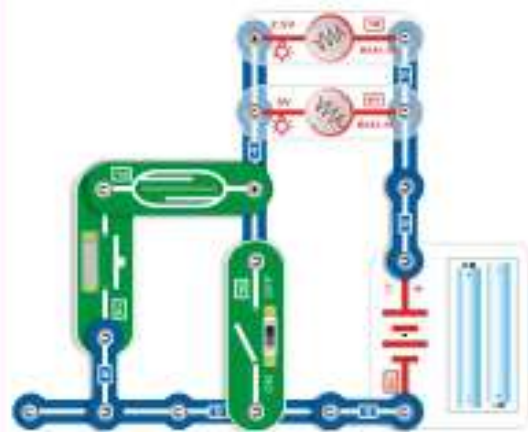

72. Three switches in parallel-series control two parallel-connected lamps(1)
Turn on the switch,the bulb lights up or press the button switch and turn on the reed switch by magnet at the same time are all can light the bulb.

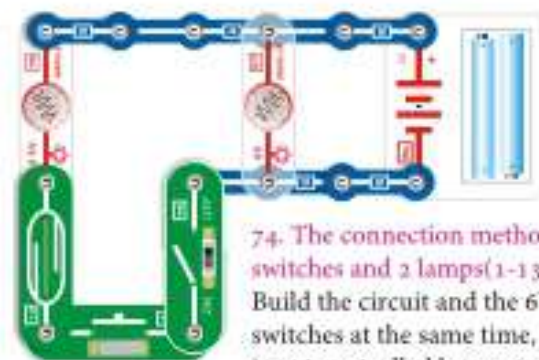

74. The connection methods for parallel-series control of 3 switches and 2 lamps(1-13)
Build the circuit and the 6V bulb lights; then turn on the 3 switches at the same time, the 2.5V bulb lights and the 6V bulb is not controlled by any switch.

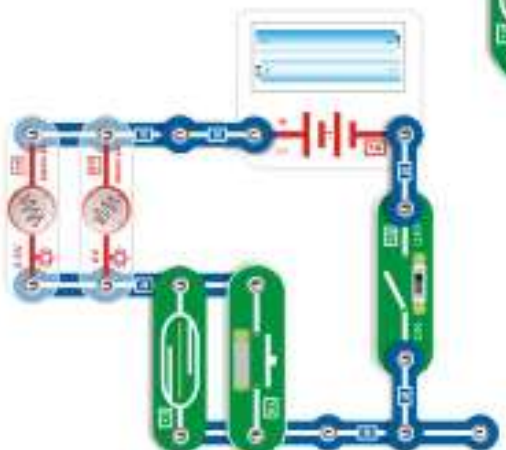

73. Three parallel-series switches control two parallel-connected lamps(2)
Turn on the switch, the bulb does not light; turn on the reed switch by magnet or press the button switch, the bulb lights; the bulb will go out after turn off the button switch and the reed switch at the same time or turn off the general switch.

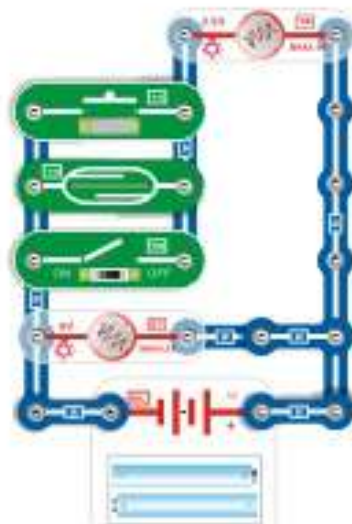

75. Parallel-series control(2)
Build the circuit and the 6V bulb lights at once; then turn on any one of the 3 switches, the 2.5V bulb lights and the 6V bulb is not controlled by any switch.



76. Parallel-series control(3)
Build the circuit and the 6V bulb lights at once; turn on the switch, then press the button switch or turn on the reed switch by magnet, the 2.5V bulb lights.

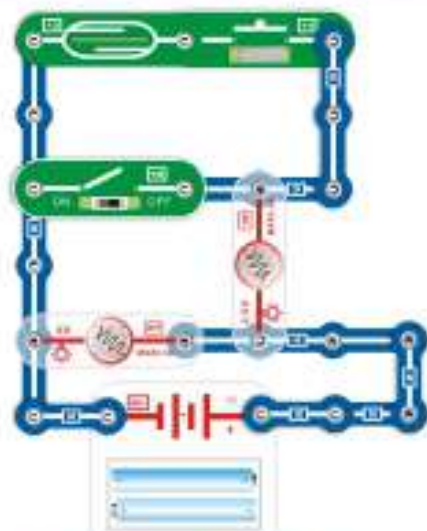

77. Parallel-series control(4)
Build the circuit and the 6V bulb lights at once; turn on the switch, then the 2.5V bulb lights; or it can light by turn on reed switch and the button switch.

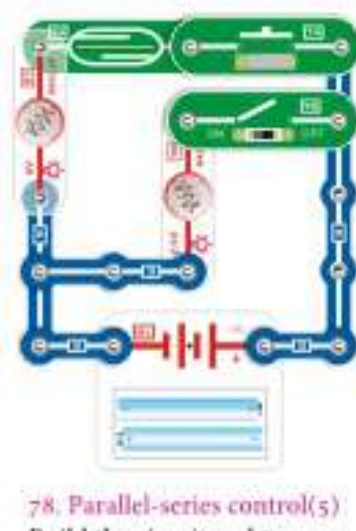

78. Parallel-series control(5)
Build the circuit and turn on the switch, the 2.5V bulb lights; 6V bulb also lights after pressing the button switch and turn on the reed switch by magnet. The two bulbs are controlled by respectively independent switch.

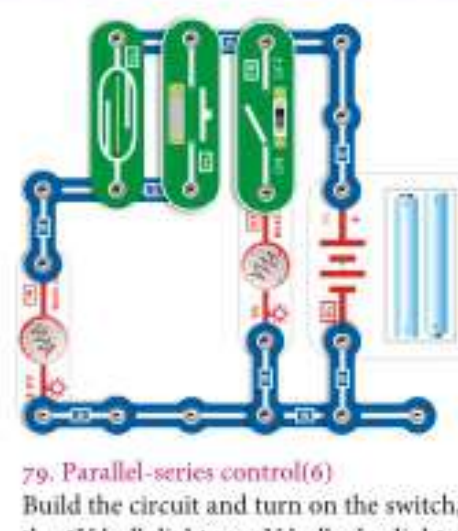

79. Parallel-series control(6)
Build the circuit and turn on the switch, the 6V bulb lights; 2.5V bulb also lights after pressing the button switch or turn on the reed switch by magnet. The two bulbs are controlled by respectively independent switch.



80. Parallel-series control(7)
Build the circuit and turn on the switch, the 2.5V bulb lights; 6V bulb also lights after pressing the button switch and turn on the reed switch by magnet, the two bulbs go out at the same time after turn off the switch.

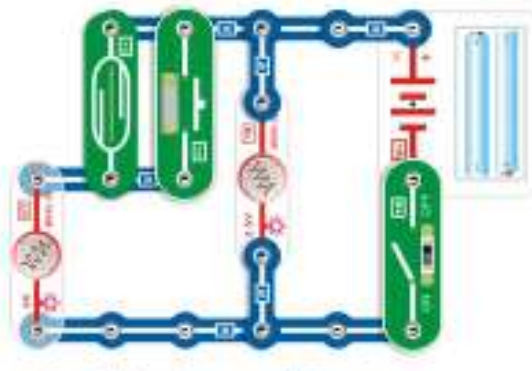

81. Parallel-series control(8)
Build the circuit and the bulbs do not light; turn on the switch, the 2.5V bulb lights; 6V bulb also lights after turn on the reed switch by magnet or pressing the button switch. The two bulbs go out at the same time after turn off the switch.

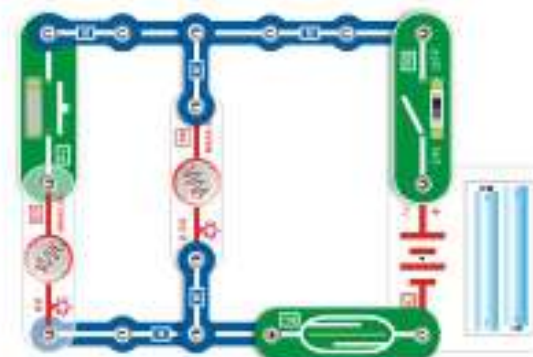

82. Parallel-series control(9)
2.5V bulb will light only after turn on the switch and reed switch at the same time; press the button switch, the 6V bulb lights; turn off the switch or reed switch, the two bulbs will go out.

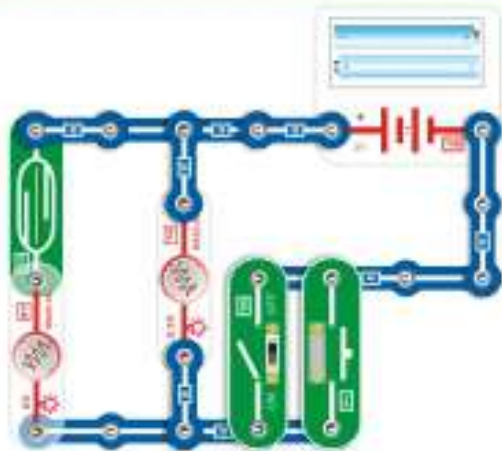

83. Parallel-series control(10)

Turn on the switch or pressing the button switch will make 2.5V bulb light; then turn on the reed switch, the 6V bulb will light; the two bulbs will both go out after turn off the switch and the button switch.

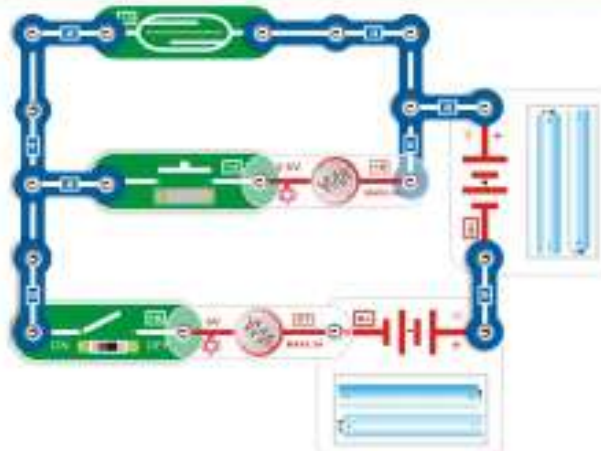

84. Parallel-series control(11)

After building the circuit and turn on the switch, the bulbs do not light; then press the button switch, both bulbs light at the same time; if turn off the reed switch, 2.5V bulb will go out and 6V bulb will become brighter.

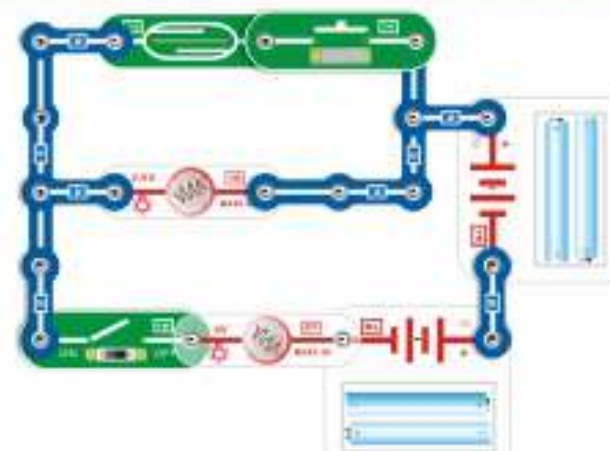

85. Parallel-series control(12)

After building the circuit and turn on the switch, both bulbs light at the same time; if turn on the button switch and reed switch, 2.5V bulb will go out and 6V bulb will become brighter.

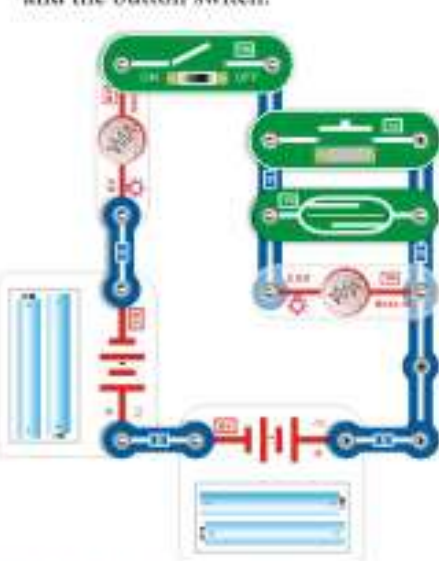

86. Parallel-series control(13)

After turn on the switch, both bulbs light at the same time; if turn on the reed switch or pressing the button switch, 2.5V bulb will go out and 6V bulb will become brighter.

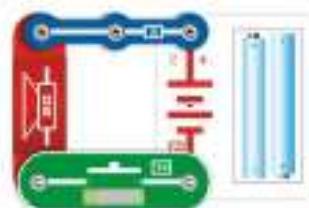

88. Function of loudspeaker

Press the button switch and the loudspeaker will give out weak sound, which is caused by the current passing through the loudspeaker. When the current is passing through the loudspeaker, which makes the paper cone vibrate and make sound.

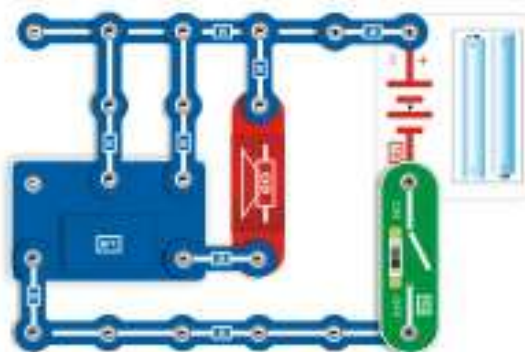

87. Birthday music

After build the circuit and turn on the switch, the loudspeaker will play beautiful birthday music; after playing for one time, it will start playing again after a short break and repeat it until the power is cut off.

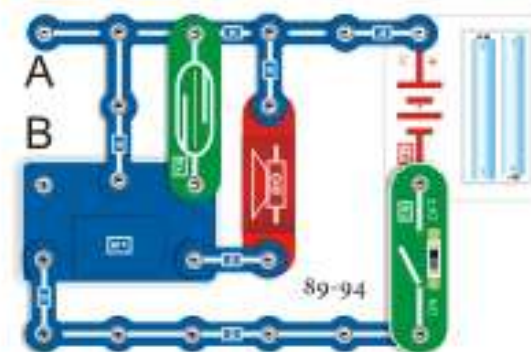

89. Magnet-controlled music doorbell

Turn on the switch and the loudspeaker will give out sound of music; when the music stops, by making the magnet turn on to the reed switch, the music will ring again; remove the magnet, the music will stop immediately; then turn on the reed switch by magnet again, the music will start again.

90. Hand-controlled music doorbell

Replace the reed switch with a button switch; when the music stops, the music can be

controlled by the button switch.

91. Light-controlled music doorbell

Replace the reed switch with a photosensitive resistor, you may use light to control the music doorbell. When there is light on the photosensitive resistor, the doorbell sounds. If the resistor is shaded from light, the music stops.

92. Water-controlled music doorbell

Replace the reed switch with touch plate, sound of music will be given out when water drips onto the touch plate.

93. Sound-controlled music doorbell

Connect a buzzer reed to terminals A and B. When music stops, if you clap your hands or speak aloud, the music will resume.

94. Motor-controlled music doorbell

Connect the motor to terminals A and B. When music stops, lightly turn the shaft of motor, the music plays again and stops automatically, lightly turn the shaft of motor once again, the music plays once again.

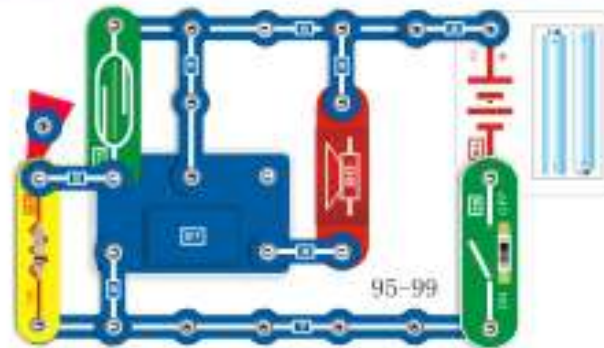

95. Magnet-controlled time delay music doorbell

Turn on the switch, the music will play; after it stops, turn on the reed switch by magnet and music will play again for one time before being stopped.

96. Hand-controlled time delay music doorbell

Replace the reed switch with a button switch, after music stops, press the button switch and release, music will play again for one time before being stopped.

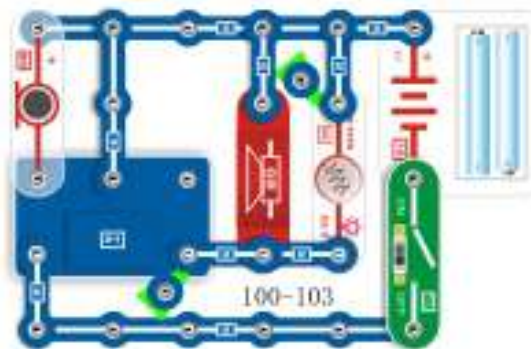

100. Sound-controlled time delay music doorbell with flash light 1

Turn on the switch, the loudspeaker produces music and bulb lights at the same time, after music stops, try blowing into the microphone or clapping your hand, the music will play again for one time before being stopped and bulb flash

synchronously once again.

101. Sound-controlled time delay music doorbell with flash light 2

Replace the microphone with a buzzer reed, the loudspeaker produces music and bulb lights at the same time, after music stops, try blowing into the buzzer reed or clapping your hand, the music will play again for one time and bulb flash synchronously once again.

102. Light-controlled time delay music doorbell with flash light

Replace the reed switch with a photosensitive resistor, the loudspeaker produces music and bulb lights at the same time, after music stops, music will play again and bulb flash synchronously once again as long as there is light on the photosensitive resistor.

103. Touch-controlled time delay music doorbell with flash light

Replace the reed switch with a touch plate, the loudspeaker produces music and bulb lights at the same time, try touching the touch plate by hand, music will play again and bulb flash synchronously once again.

97. Sound-controlled time delay music doorbell 1

Replace the reed switch with a button switch, after music stops, try blowing into the buzzer reed or clapping your hand, the music will play again for one time before being stopped.

98. Sound-controlled time delay music doorbell 2

Replace the reed switch with a buzzer reed, after music stops, try blowing into the buzzer reed or clapping your hand, the music will play again for one time before being stopped.

99. Touch-controlled time delay music doorbell 1

Replace the reed switch with a touch plate, after music stops, try touching the touch plate by hand, music will play again for one time before being stopped.

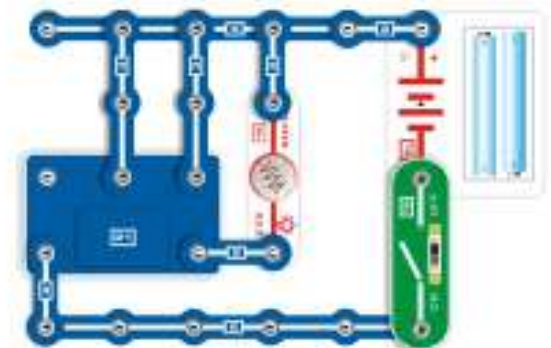

104. Flashing lamp

After building the circuit and turn on the switch, the bulb flashes. After stopping for a while, it will flash again until the power is cut off.

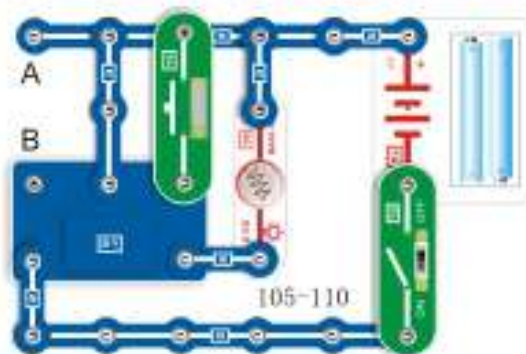

105. Hand-controlled flashing lamp

Turn on the switch. After lamp going out, the flashing lamp can be controlled by the button switch. Press the button switch, lamp lights; release the button switch, the lamp goes out immediately.

106. Magnet-controlled flashing lamp

Replace the button switch with a reed switch, and the flashing lamp can be controlled by the magnet.

107. Light-controlled flashing lamp

Replace the button switch with photosensitive resistor, and the flashing lamp can be controlled by the light after it going out. When there is light on the photosensitive resistor, the lamp lights; if no light, the lamp goes out.

108. Water-controlled flashing lamp

Replace the button switch with a touch plate, the lamp lights as long as the water drops on the touch plate.

109. Sound-controlled flashing lamp with time delay

Connect the buzzer to points A and B; after lamp going out, it will light again if clapping hands or talking loudly, and it will remain light for a while before going out.

110. Motor-controlled flashing lamp with time delay

Connect the motor to points A and B; after lamp going out, it will light again if turning the shaft of the motor slightly, and it will remain light for a while before going out.

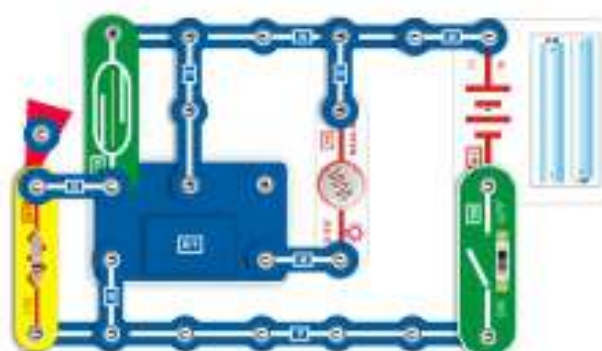

111. Magnet-controlled flashing lamp with time delay

Turn on the switch; after lamp going out, it will light again if turn on the reed switch by the magnet, and it will remain bright for a while before going out.

112. Hand-controlled flashing lamp with time delay

Replace the reed switch with a button switch. After lamp going out, the flashing lamp can light again by pressing the button switch and releasing it, and it will remain bright for a while before going out.

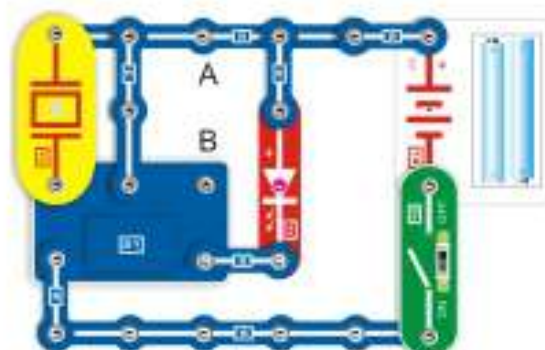

114. Time-delay sound-controlled LED

Turn on the switch, when LED goes out, clap your hands or speak aloud, the LED will light up again and go out after a period of time.

115. Time-delay motor-controlled LED

Replace the buzzer with motor, When LED goes out, turn the motor shaft lightly, the

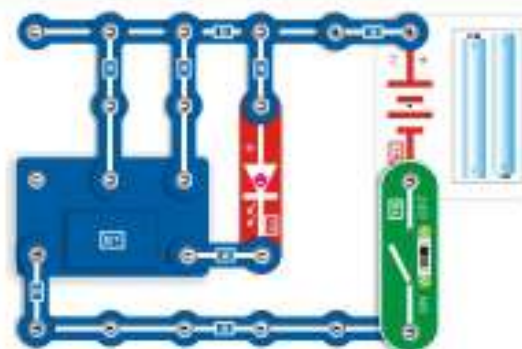

113. Intermittently flashing color lamp

After building the circuit and turn on the switch, the LED flashes and then goes out; after a while, it flashes again; the procedure is repeated until the power is cut off.

LED will light up again and go out after for a while.

116. Hand-controlled LED with light

Remove the buzzer or motor, connect the button switch between points A and B. When the LED goes out, it can be controlled with button switch.

117. Light-controlled LED (light emitting diode)

Connect a photosensitive resistor to terminals A and B, turn on the switch. After the LED goes out, it can be controlled by light.

118. Water-controlled LED

Connect the touch plate to terminals A and B. If water drips onto the touch plate, LED lights again.

119. Magnetic-controlled LED with light

Connect the reed switch between points A and B. When the LED goes out, it can be controlled with magnet.

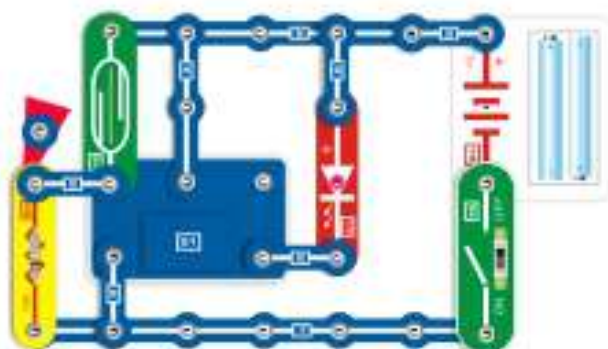

120. Magnetic-controlled time delay lamp

Turn on the switch, When the LED goes out, hold a magnet near the reed switch and then move the magnet away, the lamp will light up again and remain lighting up for some time.

121. Hand-controlled LED with time delay

Replace the reed switch with button switch, When the LED goes out, press the button then release, the lamp will light up again and remain lighting up for some time.



122. Light-controlled double flashing lamp

Turn on the switch. After LED and bulb goes out, LED and bulb can be controlled by light.

123. Water-controlled double flashing lamp

Replace the photosensitive resistor with a touch plate, and then you may use the water to control the double flashing lamp.

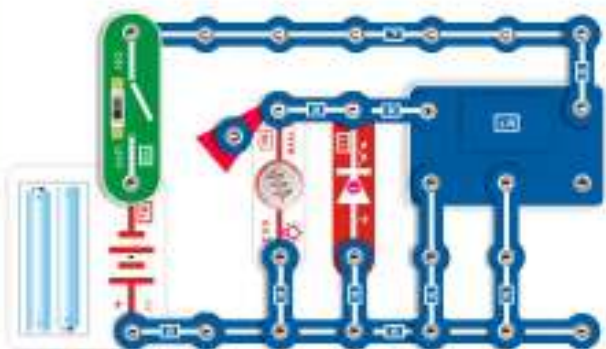

128. Intermittent double flashing lamp

Build the circuit and turn on the switch, the LED and bulb will both light up at the same time until the power is cut off.

Question: Remove anyone of the wire 3 in the circuit, will it keep the same effects as before?



129. Magnet-controlled double flashing lamp with time delay

Turn on the switch, the LED and bulb will light at the same time; after lamp going out, LED and bulb will light again if turn on the reed switch by the magnet, and they will stay on for a while before going out.

130. Hand-controlled double flashing lamp with time delay

Replace the reed switch with a button switch and after lamp going out, LED and bulb can light again by pressing the button switch and releasing it, and they will stay on for a while before going out.



131. Hand-controlled time-delay music motor

Turn on the switch and motor gives out weak music, after music stops, press the button switch and release it, the motor will sound of music again and stop after playing a song.

132. Magnet-controlled time-delay music motor

Replace the button switch with a reed switch, after music stops, turn on the reed switch by the magnet, the motor will sound of music again and stop after playing a song.

124. Magnet-controlled double flashing lamp

Replace the photosensitive resistor with a reed switch, the double flashing lamp can be controlled by the magnet.

125. Hand-controlled double flashing lamp

Replace the photosensitive resistor with a button switch, the double flashing lamp can be controlled by hand.

126. Sound-controlled double flashing lamp with time delay

Connect the buzzer to points A and B; after lamp going out, LED and bulb will light again if clapping hands or talking loudly, and it will remain light for a while before going out.

127. Motor-controlled double flashing lamp with time delay

Connect the motor to points A and B; after lamp going out, LED will light again if turning the shaft of the motor slightly, and it will remain light for a while before going out.

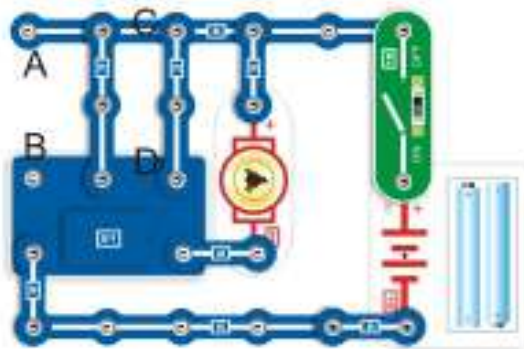

133. Singing motor

Turn on the switch, and the motor gives out weak music.

134. Light-controlled music motor

Replace the wire 3 between points C and D with a photosensitive resistor, and music motor can be controlled by the light.

135. Water-controlled music motor

Replace the wire 3 between points C and D with a touch plate, and music motor can be controlled by the water drop.

136. Magnet-controlled music motor

Replace the wire 3 between points C and D with a reed switch, and music motor can be controlled by the magnet.

137. Hand-controlled music motor

Replace the wire 3 between points C and D with a button switch, and music motor can be controlled by the hand.

138. Sound-controlled music motor

Remove the wire 3 between points C and D, connect the buzzer with points A and B, and music motor can be controlled by the hand.

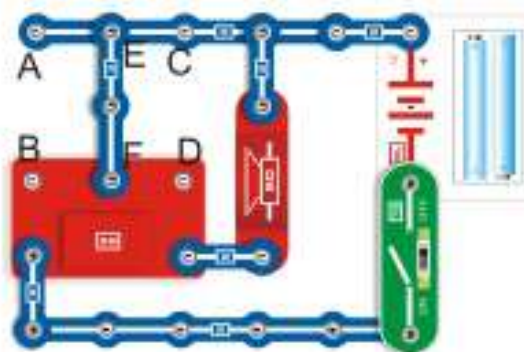

139. Sound of patrol wagon

Turn on the switch, the loudspeaker will give out the sound of patrol wagon.

140. Sound of machine gun

Connect C to D and E to F separately, the loudspeaker will give out the sound of machine gun.

141. Sound of fire engine

Connect A to B and E to F separately, the loudspeaker will give out the sound of fire engine.

142. Sound of ambulance

Connect E to F and B to G separately, the loudspeaker will give out the sound of ambulance.

143. Buddha laugh

Connect E to F and B to D separately, the loudspeaker will give out the sound of Buddha laugh.

144. Magnet-controlled sound of patrol wagon

145. Magnet-controlled sound of machine gun

146. Magnet-controlled sound of fire engine

147. Magnet-controlled sound of ambulance

148. Magnet-controlled sound of Buddha laugh

(144-148) According to the link way of (139-142).

Replace the switch with the reed switch, upwards five sound can be controlled by magnet.

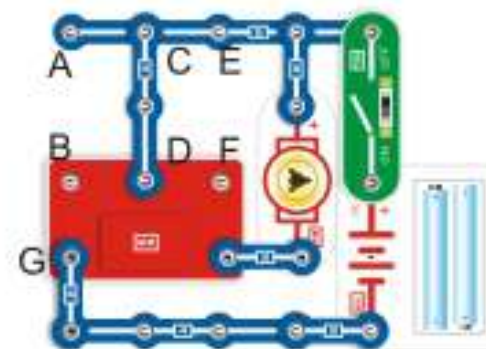

149. Moto-controlled sound of patrol wagon

Built the circuit, turn on the switch, the motor will produce weak sound of patrol wagon.

150. Motor-controlled sound of machine gun

Connect C to D and E to F, turn on the switch, the motor will produce small sound of machine gun.

151. Motor-controlled sound of fire engine

Connect A to B and C to D, turn on the switch, the motor will produce small sound of fire engine.

152. Motor-controlled sound of ambulance

Connect C to D and B to G, turn on the switch, the motor will produce small sound of ambulance.

Notes: In this circuit, if the motor rotates but no sound, can hold the shaft of motor by hand after the motor stop rotating and place the magnet close to the reed switch at the same time, then motor will produce sound. (Warning: Do not touch the motor during operation. Do not lean over the motor.)

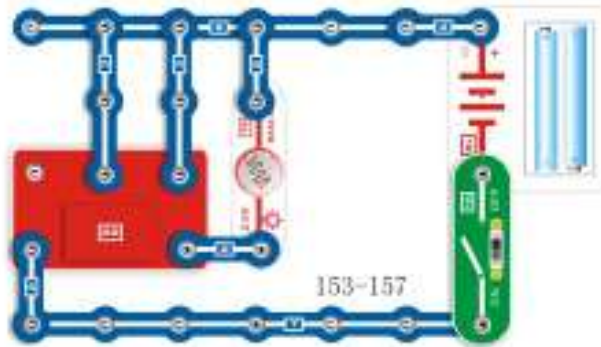

153. Intermittently flashing lamp

Turn on the switch and the lamp flashes.

154. Magnet-controlled intermittently flashing lamp

Replace the switch with a reed switch, place the magnet close to the reed switch, the bulb flashes or goes out repeatedly; remove the magnet and the bulb goes out.

155. Flashing LED

Replace the bulb with a LED, turn on the switch and the LED flashes and goes out repeatedly.

156. Magnet-controlled flashing LED

Replace the switch with a reed switch, the flashing LED will flash can be controlled with magnet.

157. Button switch-controlled flashing LED

Replace the switch with a button switch, the flashing LED can be controlled by button switch.

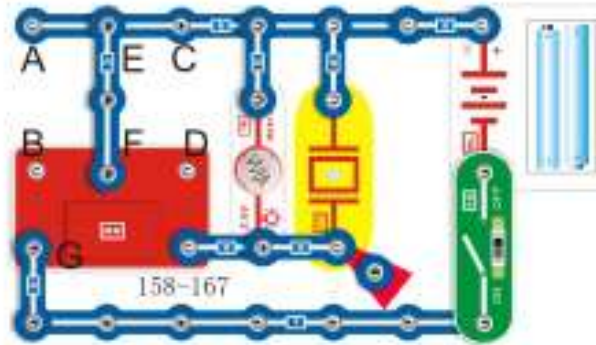

158. Acousto-optic buzz police wagon sound

Turn on the switch, the buzzer gives out the sound of police wagon, and lamp lights at the same time.

159. Acousto-optic buzz sound of machine gun

Connect E to F and C to D respectively, the buzzer will give out the sound of machine gun.

160. Acousto-optic buzz sound of fire engine

Connect E to F and A to B respectively, the buzzer will give out the sound of fire engine.

161. Acousto-optic buzz sound of ambulance

Connect E to F and B to G respectively, the buzzer will give out the sound of ambulance.

162. Acousto-optic buzz sound of Buddha laugh

Connect E to F and B to D respectively, the buzzer will give out the sound of Buddha laugh.

163. Magnet-controlled acousto-optic buzz sound of police wagon

164. Magnet-controlled acousto-optic buzz sound of machine gun

165. Magnet-controlled acousto-optic buzz sound of fire engine

166. Magnet-controlled acousto-optic buzz sound of ambulance

167. Magnet-controlled acousto-optic buzz sound of Buddha laugh

163-167: Connect according the connection methods of 158-162, then replace the switch with a reed switch, and the above 5 sounds can be controlled by the magnet.

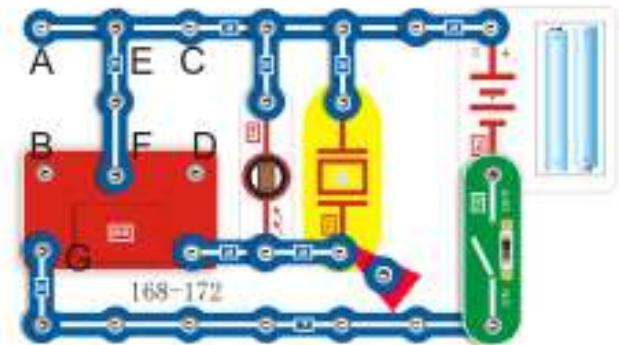

168. Light-controlled buzz volume sound of police wagon

Turn on the switch, when there is light on the photosensitive resistor, the buzzer will give out the sound of police wagon, and the intensity of the light will determine the volume.

169. Light-controlled buzz volume sound of machine gun

Connect E to F and C to D respectively, and the intensity of the light will determine the volume of machine gun.

170. Light-controlled buzz volume sound of fire engine

Connect E to F and A to B respectively, and the intensity of the light will determine the volume of fire engine.

171. Light-controlled buzz volume sound of ambulance

Connect E to F and B to G respectively, and the intensity of the light will determine the volume of ambulance.

172. Light-controlled buzz volume sound of Buddha laugh

Connect E to F and B to D respectively, and the intensity of the light will determine the volume of sound of Buddha laugh.

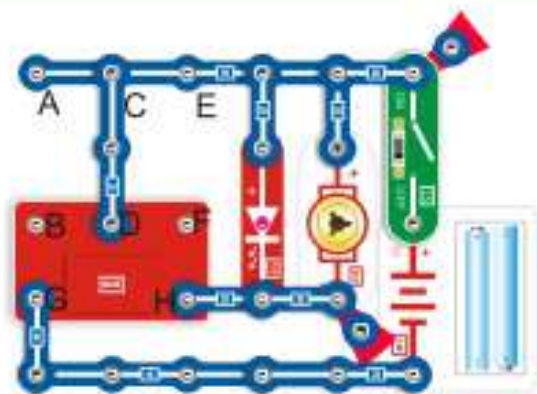

173. Red light motor-controlled sound of patrol wagon

Build the circuit, turn on the switch, the motor will produce small sound of patrol wagon. The brightness of led vary with changes of the sound at the same time.

174. Red motor-controlled sound of machine gun
Connect C to D and E to F, turn on the switch, the motor will produce small sound of machine gun. The brightness of led vary with changes of the sound at the same time.

175. Motor-controlled sound of fire engine
Connect A to B and C to D, turn on the switch, the motor will produce small sound of fire engine. The brightness of led vary with changes of the sound at the same time.

176. Red light motor-controlled sound of ambulance
Connect C to D and B to G, turn on the switch, the motor will produce small sound of ambulance. The brightness of led vary with changes of the sound at the same time.

177. Red light motor-controlled sound of Buddha laugh

Connect C to D and B to F, turn on the switch, the motor will produce small sound of Buddha laugh. The brightness of led vary with changes of the sound.

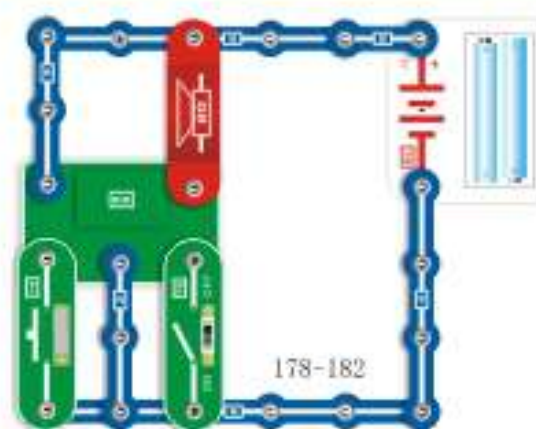

178. Hand-controlled space war

Operate the switch and the button with hands, you will have sounds of various weapons as if a space war is under way.

179. Magnet-controlled space war
Replace the switch with a reed switch, the space war can be controlled with a magnet.

180. Light-controlled space war
Replace the switch with a photosensitive resistor. If shield the photosensitive resistor from light by hand repetitively, you can control the space war.

181. Touch-controlled space war
Replace the button with a touch plate. If you touch the touch plate repeatedly, you can control the space war.

182. Water-controlled space war
Replace the loudspeaker with a red LED and the switch with a touch plate; as long as water drops on the touch plate, the loudspeaker will play the sound of space war.

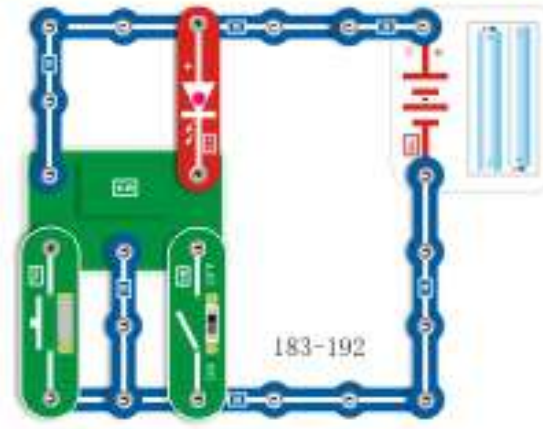

183. Hand-controlled flashing LED

Touch the switch or button switch, the LED will flash.

184. Magnet-controlled flashing LED
Replace the switch with reed switch, the LED can be controlled by magnet.

185. Light-controlled flashing LED
Replace the switch with photosensitive resistor, shield the photosensitive resistor from light by hand, the LED is controlled by the photoresistor.

186. Touch-controlled flashing LED
Replace the reed switch with touch plate, press the touch plate then release, the LED is controlled by touch.

187. Rain-controlled flashing LED
Replace the button switch with touch plate, If there is rain dripping onto the touch plate, the LED will flash.

188. Hand-controlled flashing lamp

189. Magnet-controlled flashing lamp

190. Light-controlled flashing lamp

191. Touch-controlled flashing lamp

192. Rain-controlled flashing lamp

188-192, Replace the LED with 2.5V bulb, the rest operations are the same as above, it can be controlled the flashing lamp.

Question: Whether sound controll or not? Please have a try.

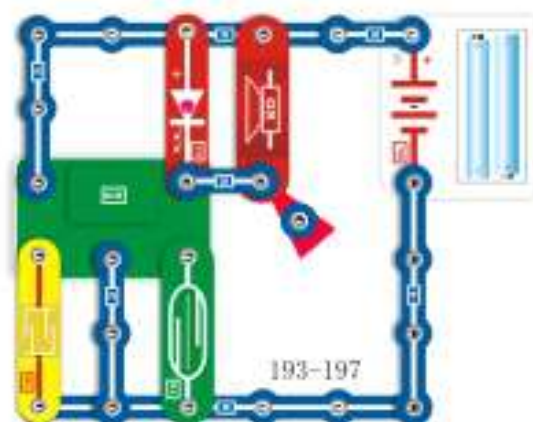

193. Touch-controlled acousto-optic space war
Build the circuit, touch the touch plate repeatedly, all kinds of sounds of space war will be given out, and LED will flash at the same time.

194. Magnet-controlled acousto-optic space war
Turn on the reed switch repeatedly by the magnet, the loudspeaker will give out all kinds of sounds, and LED will flash.

195. Water-controlled acousto-optic space war
Interchange the positions of touch plate and reed switch, when water drops on the touch plate, the loudspeaker will give out all kinds of sounds of space war, and LED will flash at the same time.

196. Light-controlled acousto-optic space war
Connect the photosensitive resistor in the original position of the reed switch, when there is light on photosensitive resistor, the loudspeaker will give out all kinds of sounds of space war, and LED will flash at the same time.

197. Hand-controlled acousto-optic space war
Replace the touch plate with a button switch, and the acousto-optic space war can be controlled by the hand.

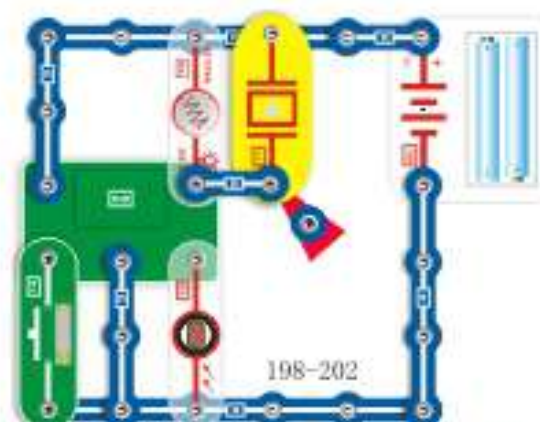

198. Light-controlled buzz acousto-optic space war
Build the circuit, when there is light on photosensitive resistor, the buzzer will give out all kinds of sounds of space war, and the lamp will light at the same time.

199. Magnet-controlled buzz acousto-optic space war
Replace the photosensitive resistor with a reed switch, and the acousto-optic space war can be controlled by the magnet.

200. Water-controlled buzz acousto-optic space war
Replace the photosensitive resistor with a touch plate, when water drops on the touch plate, the buzzer will give out all kinds of sounds of space war, and the lamp will light at the same time.

201. Hand-controlled buzz acousto-optic space war
Press the button switch by hand directly, the buzzer will give out all kinds of sounds of space war, and the lamp will light at the same time.

202. Touch-controlled buzz acousto-optic space war
Replace the button switch with a touch plate, and touch the touch plate repeatedly, the buzzer will give out all kinds of sounds of space war, and the lamp will light.

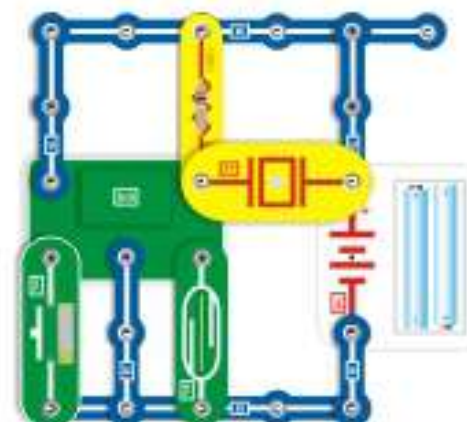

203. Magnet-controlled buzz space war
Place the magnet close to the reed switch, the buzzer will give out the sound of space war.

204. Light-controlled buzz space war
Replace the reed switch with photosensitive resistor, when there is light on photosensitive resistor, the buzzer will give out the sound of space war.

205. Hand-controlled buzz space war
Press the button switch by hand directly, the buzzer will give out the sound of space war.

206. Touch-controlled buzz space war
Replace the button switch with a touch plate, and touch the touch plate, the buzzer will give out the sound of space war.

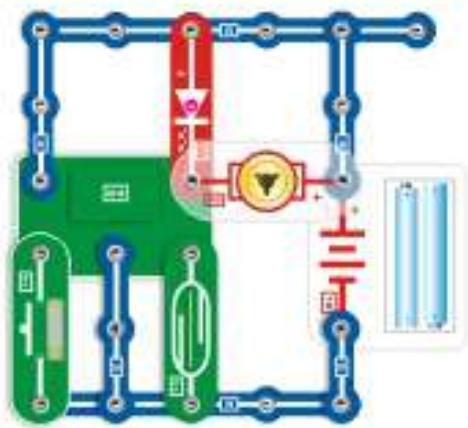

207. Magnet-controlled motor activated acousto-optic space war

Turn on the reed switch by the magnet, the motor will give out weak sound of space war and LED will give out weak light at the same time.

208. Light-controlled motor activated acousto-optic space war

Replace the reed switch with a photosensitive, when there is light on photosensitive resistor, the loudspeaker will give out all weak sounds of space war, and LED will give out weak light at the same time.

209. Hand-controlled motor activated acousto-optic space war

Press the button switch by hand, the motor will give out the weak sound of space war, and LED will give out weak light at the same time.

210. Touch-controlled motor activated acousto-optic space war

Replace the button switch with a touch plate, touch the touch plate by hand, the motor will give out weak sounds of space war, and LED will give out weak light at the same time.

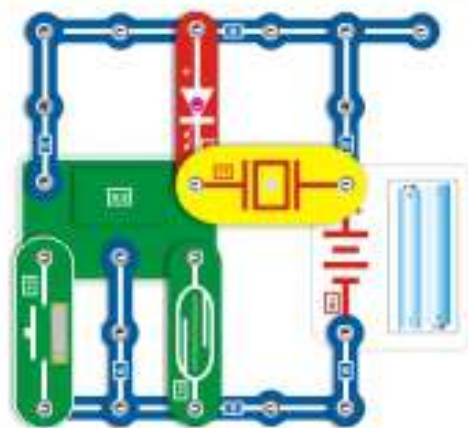

211. Magnet-controlled buzz space war with light

Place the magnet close to the reed switch, the buzzer will give out the sound of space war and the led lights at the same time.

212. Light-controlled buzz space war with light

Replace the reed switch with photosensitive resistor, when there is light on photosensitive resistor, the buzzer will give out the sound of space war and the led lights at the same time.

213. Hand-controlled buzz space war with light

Press the button switch by hand directly, the buzzer will give out the sound of space war and the led lights at the same time.

214. Touch-controlled buzz space war with light

Replace the button switch with a touch plate, and touch the touch plate by hand, the buzzer will give out the sound of space war and the led lights at the same time.

216. Amplifying effect of PNP triode

Assemble the circuit as shown, slowly adjust the varistor downward. When the LED lights, the bulb also lights up. This is because of the amplifying effect of triode, i.e. when a small current flows through base B of the triode, there is a higher current flowing through emitter E and collector C. This is the current amplifying function of a triode.

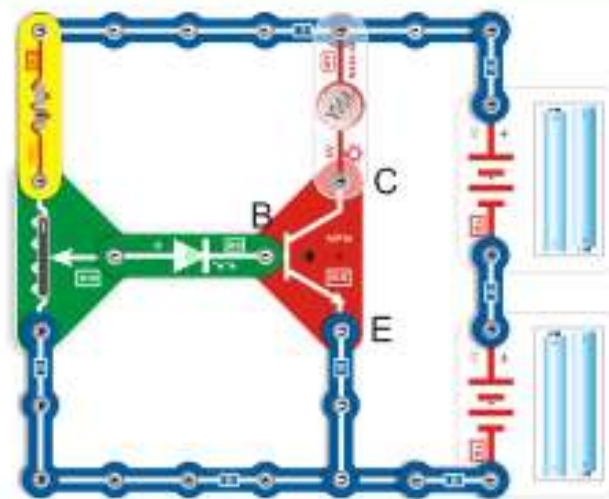

215. Amplification effect of NPN triode

A triode has 3 poles and they are called emitter, base and collector respectively. If there is a small current passing through base B of a triode, there will be higher current flowing through emitter E and collector C. This is the amplifying effect of a triode. Assemble the circuit as shown, slowly adjust the varistor in upward direction. When the LED lights, the bulb also lights up. There is a small current flowing through base B but a higher current flowing through collector C.

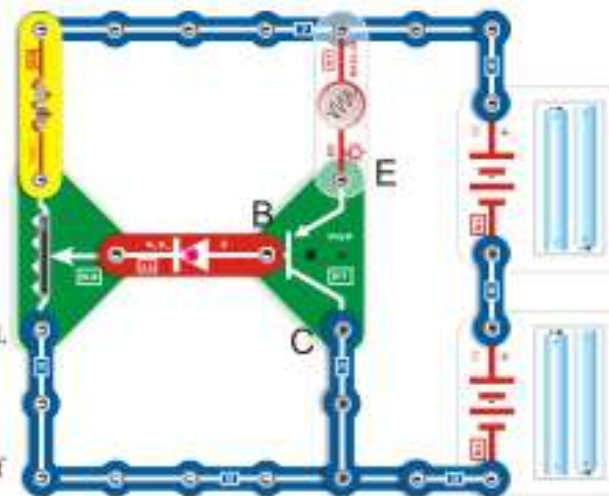

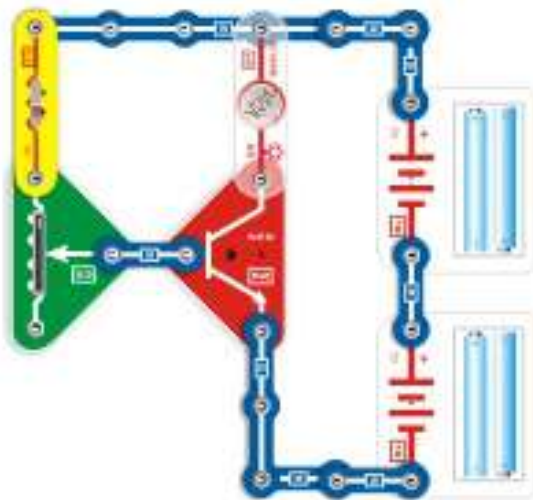

217. Single variable luminosity lamp(1)
 218. Single variable speed fan(1)
 219. Magnet-controlled single variable luminosity lamp(1)
 220. Magnet-controlled single variable speed fan(1)

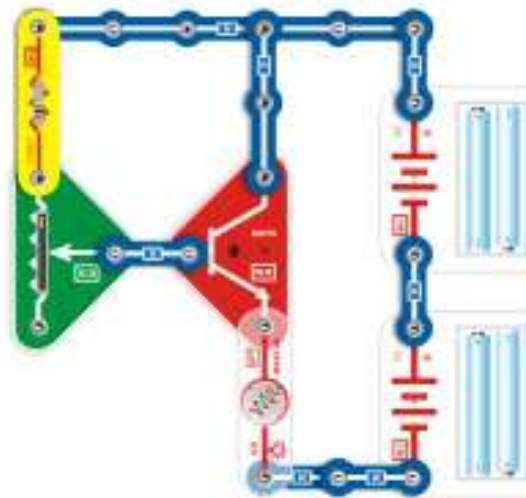

225. Single variable luminosity lamp(3)
 226. Single variable speed fan(3)
 227. Magnet-controlled single variable luminosity lamp(3)
 228. Magnet-controlled single variable speed fan(3)

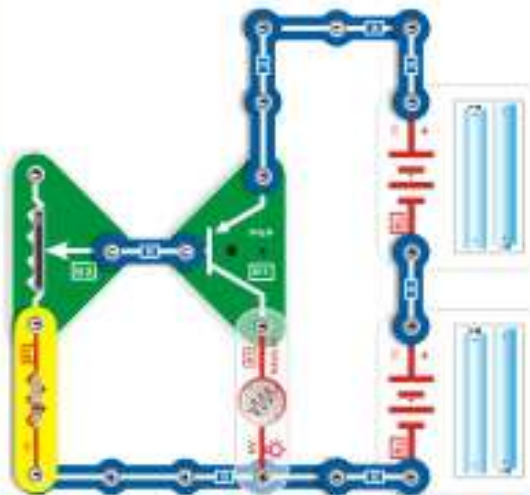

221. Single variable luminosity lamp(2)
 222. Single variable speed fan(2)
 223. Magnet-controlled single variable luminosity lamp(2)
 224. Magnet-controlled single variable speed fan(2)

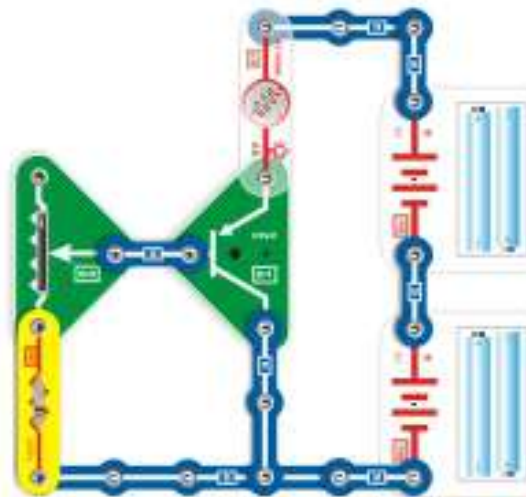

229. Single variable luminosity lamp(4)
 230. Single variable speed fan(4)
 231. Magnet-controlled single variable luminosity lamp(4)
 232. Magnet-controlled single variable speed fan(4)

216/220/224/228/The functions and operations of these variable luminosity lamps are the same; turn on the switch, slowly adjust the variable resistor, the luminosity of the lamp will change accordingly.

217/221/226/229 Replace the bulb with a motor and install the fan blade. When adjusting the variable resistor slowly, the rotation speed of the fan will change accordingly.

218/221/226/230 Replace the switch with a reed switch. When adjusting the brightness of the bulb, the bulb will light or go out under the control of magnet.

219/223/227/231 Replace the switch with a reed switch and the bulb with a motor. When adjusting the rotation speed of the fan, they fan will rotate or stop under the control of magnet.



233. Touch switch-controlled LED

Replace the bulb with a LED, the LED lights when touch the touch plate by hand.

234. Touch -controlled lamp

Build the circuit as shown in the diagram, turn on the switch, the LED lights when touch the touch plate by hand.

235. Light-controlled lamp

Replace the touch plate with a photosensitive resistor, the bulb will light when there is light on the photosensitive resistor.

236. Light-controlled LED

Replace the touch plate with a photosensitive resistor, the LED will light when there is light on the photosensitive resistor.

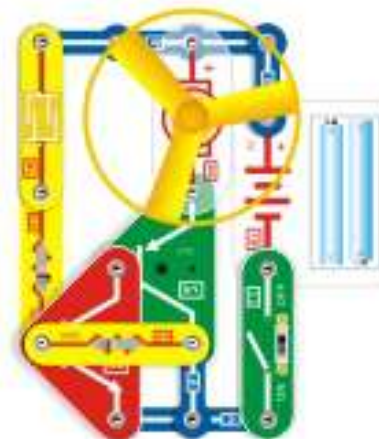

237. Touch -controlled fan

Build the circuit as shown in the diagram, turn on the switch, the fan will spin when touch the touch plate by hand.

238. Light-controlled fan

Replace the touch plate with a photosensitive resistor, the fan will spin when there is light on the photosensitive resistor.

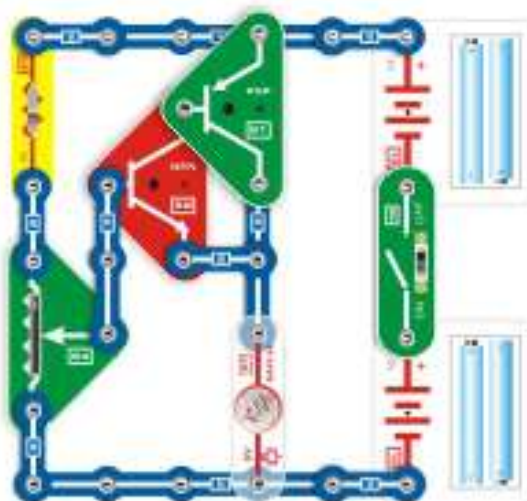

239. Combined-transistors variable luminosity lamp(1)

240. Combined-transistors variable speed fan(1)

241. Combined-transistors variable luminosity lamp(2)

242. Combined-transistors variable speed fan(2)

239/241 These two lamps are of the same function and operation, turn on the switch, slowly adjust the varistor, luminosity of the lamp will vary accordingly; this different from single variable luminosity lamp, this circuit provides equal variation in luminosity of lamp.

240/242 Replace the bulb with motor, install fan blade. Slowly adjust the varistor, fan speed will vary in equal accordingly.

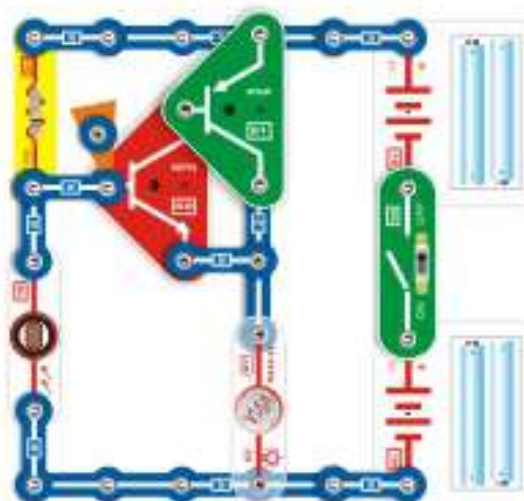

243. Simple automatic street lamp(1)

244. Simple automatic electric fan(1)

245. Simple light-controlled lamp(1)

246. Simple light-controlled electric fan(1)

243/247 Turn on the switch. The street lamp will light automatically at night and will go out automatically with dawn coming.

244/246 Replace the bulb with the motor and install the fan blade, then turn on the switch. The fan will start rotating at night and stop rotating automatically with dawn coming.

245/251 Interchange the position of the photosensitive resistor and the 100K resistor, shield the photosensitive resistor from light by hand, the bulb goes out. If there is light on the photosensitive resistor, the bulb will light up.

246/252 Replace the bulb with the motor, when there is light on the photosensitive resistor, the fan will rotate. Shield the photosensitive resistor from light by hand, the fan stops.



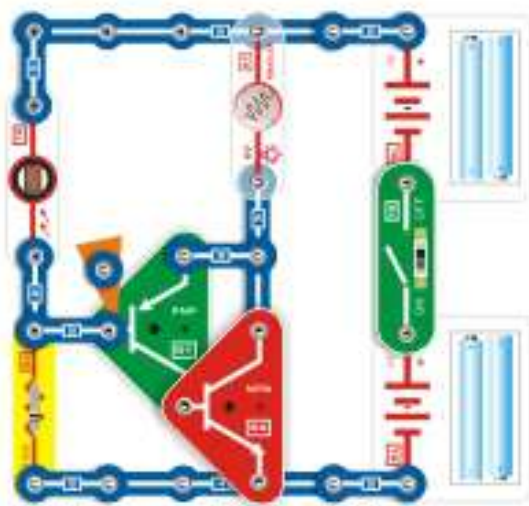

247. Simple electric street lamp(2)

248. Simple automatic electric fan(2)

249. Simple light-controlled lamp(2)

250. Simple light-controlled electric fan(2)

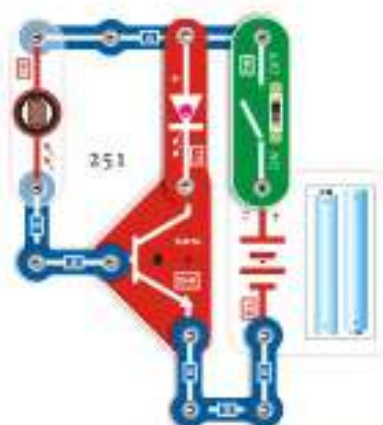

251. Light-activated LED(1)

252. Light-activated LED(2)

251-252, Turn on the switch. As long as there is light on the photosensitive resistor, the LED will light.

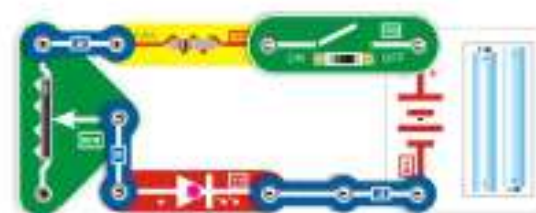
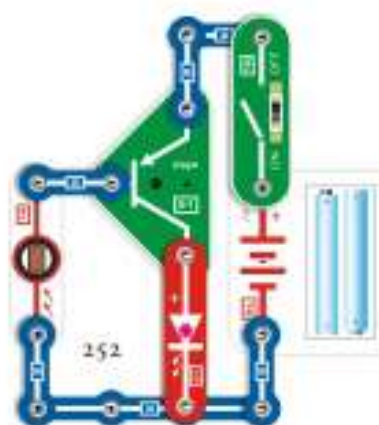

255. LED of adjustable luminosity

Turn on the switch, adjust the variable resistor and the luminosity of LED will be varied.



253. Dark-activated LED(1)

254. Dark-activated LED(2)

253/254 Turn on the switch, shield the photosensitive resistor from light by hand, and the LED will light; when there is light on the photosensitive resistor, the LED will go out.



256. Time-delay lamp(1)

Build the circuit and press the button switch, the lamp will light after some delay.

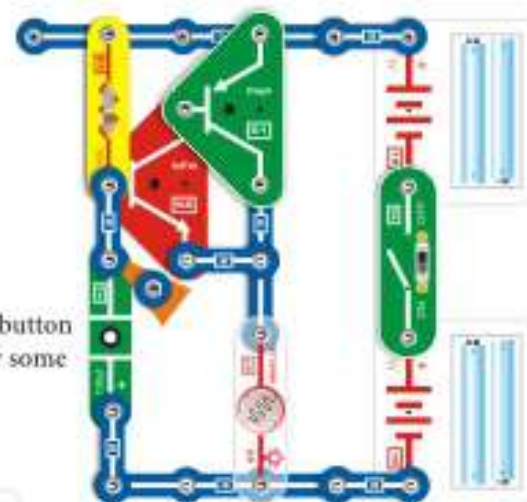
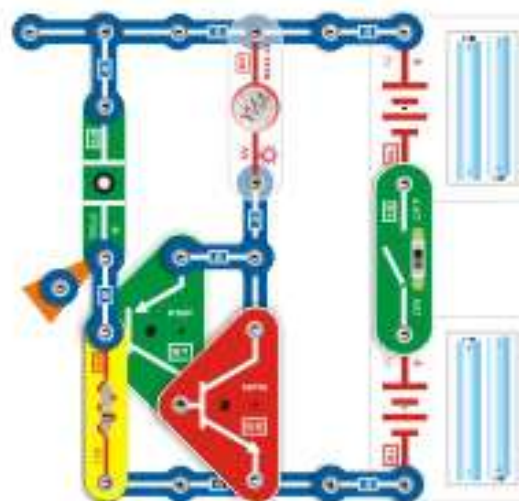

257. Time-delay lamp(2)

Build the circuit and press the button switch, the lamp will light after some delay.

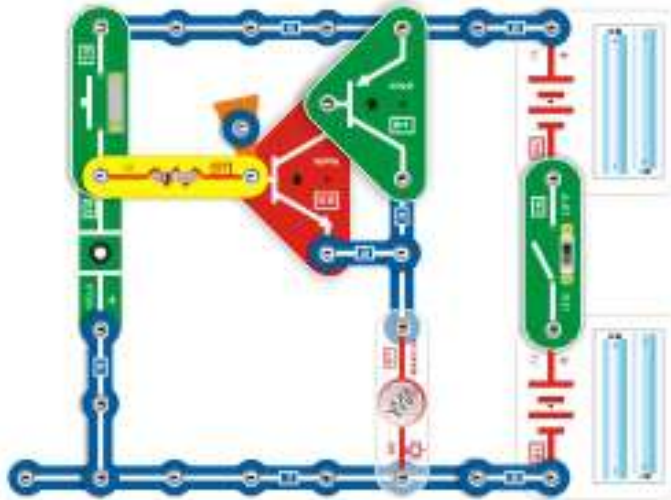

258. Timed beside lamp(1)

259. Simple timed electric fan(1)

259/261 Replace the bulb with a motor, put on the blade, press the button switch, the motor start rotating, the fan runs on slowly but stays on for a while after you release the button switch. You can change the delay time with the adjustable resistor.



260. Timed beside lamp(2)

261. Simple timed electric fan(2)

262. Unresponsive lamp(1)

Turn on the switch, press the button switch, the bulb lights after a delay; release the button switch, the bulb goes out also after a delay.

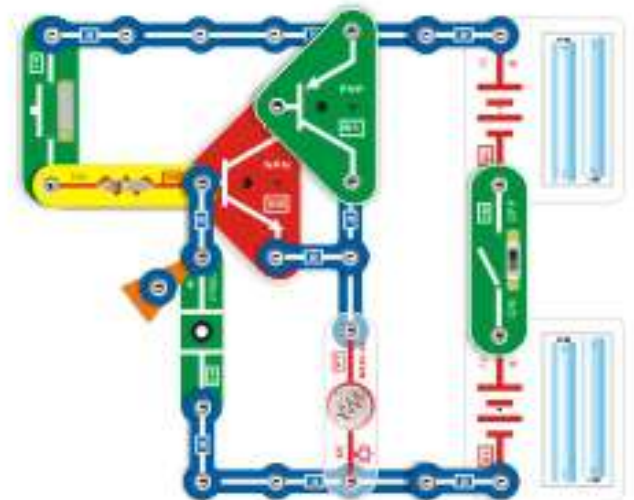
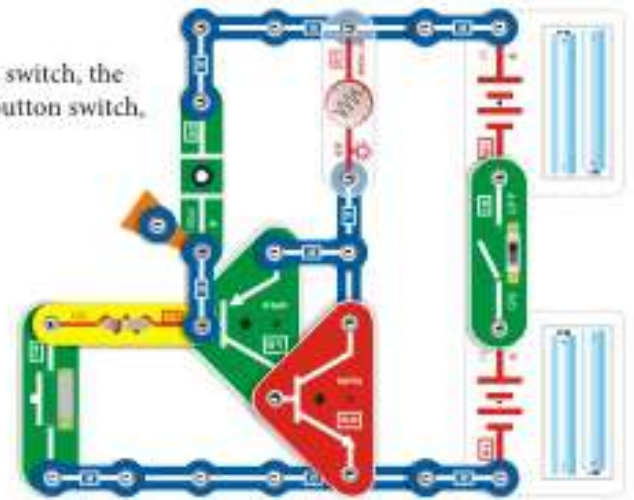

263. Unresponsive lamp(2)

Turn on the switch, press the button switch, the bulb lights after a time delay; release the button switch, the bulb goes out also after a time delay.

Question: If replace the button switch with the wire 3 or reed switch, what will be happened?

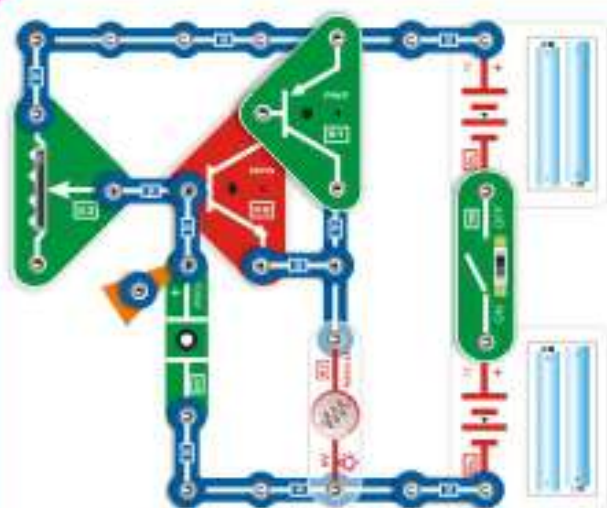

264. Adjustable timed lamp(1)

264/265 Press the button switch, the lamp will light after some delay; you can change the delay time with the adjustable resistor.

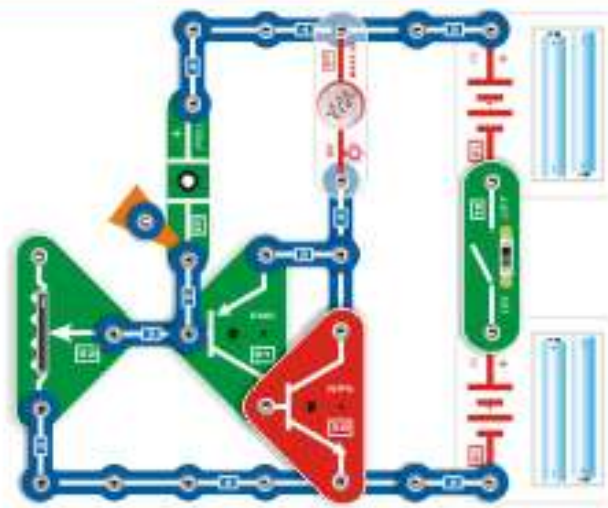

265. Adjustable timed lamp(2)

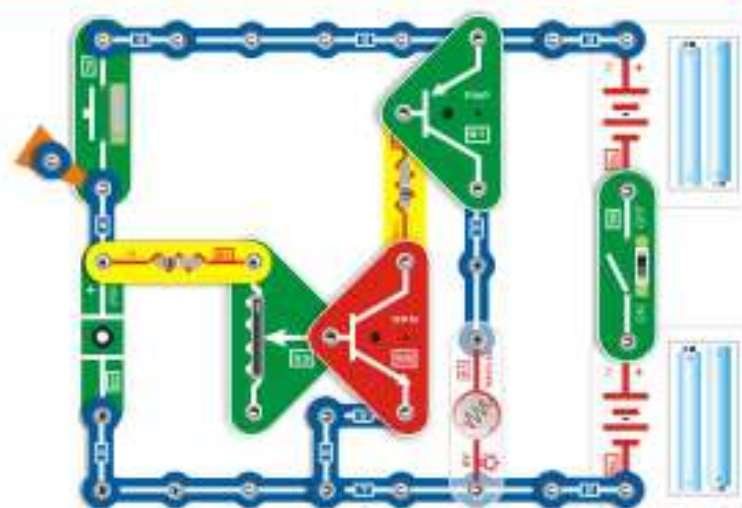

266. Adjustable Timed lamp(1)

267. Adjustable timed fan(1)

266/268: Turn on the switch and press the button switch, the bulb lights; the bulb will stay on for a while after you release the button switch. you can change the delay time with the adjustable resistor.

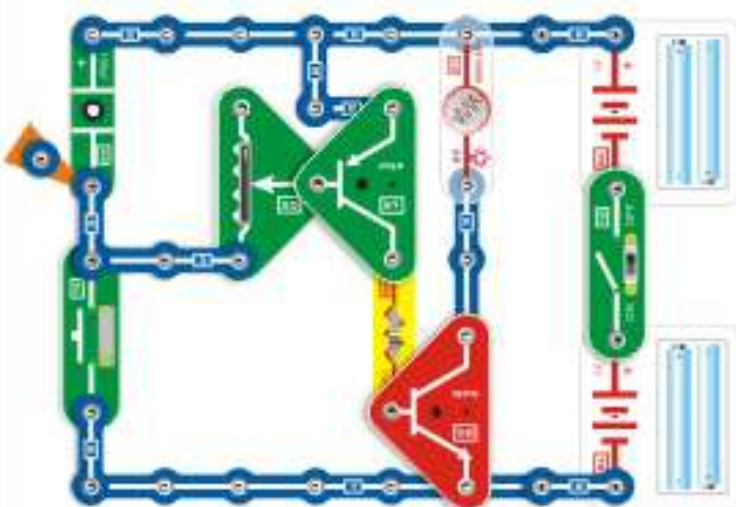

268. Adjustable Timed lamp(2)

269. Adjustable timed fan(2)

267/269 Replace the lamp with a motor, install the fan blade, press the button switch, the fan rotates; the fan stays on for a while after you release the button switch, you can change the delay time with the adjustable resistor.

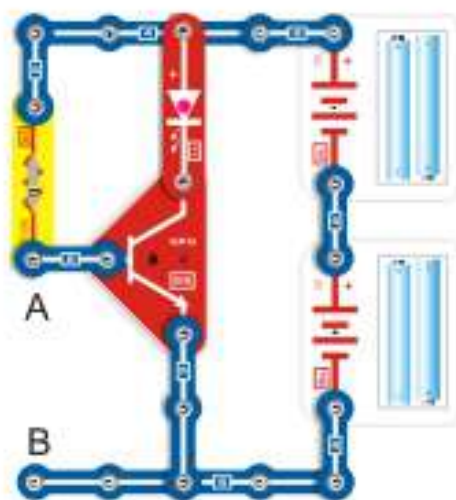

270. Single anti-theft alarm lamp(1)

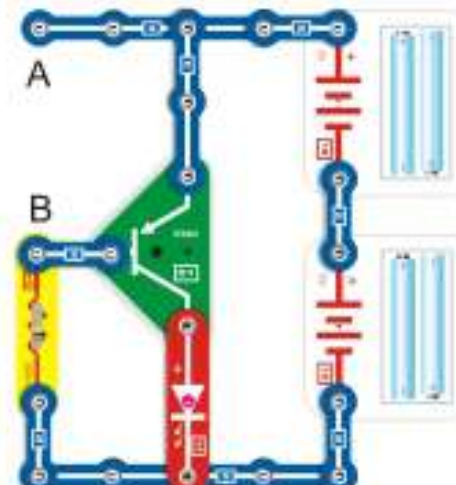

271. Single anti-theft alarm lamp(2)

270/271: Use a long and thin lead go through the bicycle, motorcycle, car, door or window, then connect the two ends of the lead with points A and B, which can defend against the theft. When the thief breaks the lead, the LED will light and alarm immediately.

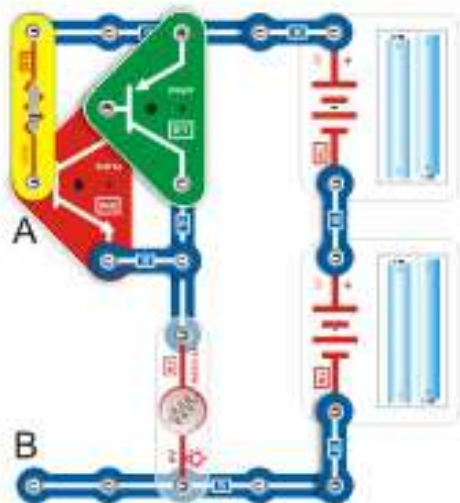

272. Combined-transistors anti-theft alarm lamp(1)

The operation method is the same as 239-240: When the thief breaks the lead, the LED will light and alarm immediately. Question! Interchange the position of No.52 and No.53, is it the same effects?

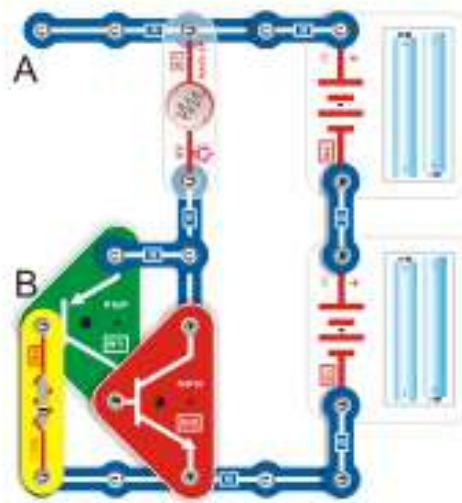

273. Combined-transistors anti-theft alarm lamp(2)

The operation method is the same as 270-271: When the thief breaks the lead, the LED will light and alarm immediately.

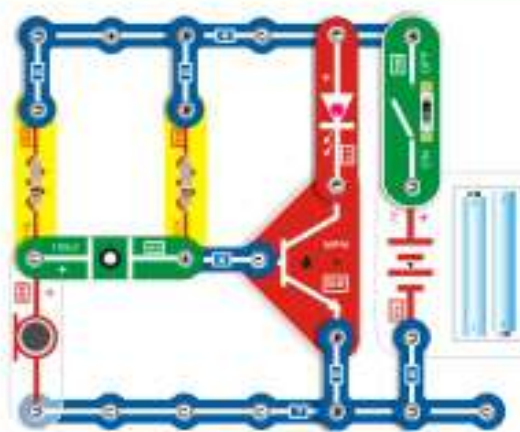

274. Sound-controlled flashing color lamp

Turn on the switch, the LED light weakly, then blow to the microphone or put the microphone near the TV, radio, loudspeaker of acoustic, LED will flash according to the volume of sound.

275. Motor-controlled flashing color lamp

Replace the microphone with a motor, turn the shaft of motor, LED will flash.



276. Blow out the lamp

Build the circuit, the lamp lights up. If you blow to the microphone, the lamp will go out for a second and then will light up again.

277. Lamp that goes out but lights again(1)

Replace the microphone with a photosensitive resistor, when lamp lights, if shield the photosensitive resistor from light by hand, the lamp goes out for a second and then lights up again.

278. Instant stop lamp(1)

Replace the photosensor with a button switch, press the button switch and release it, the lamp goes out but lights after a while.

279. Instant stop electric fan(1)

Replace the lamp with the motor, press the button switch and release it, the rotate speed of the electric fan is slow down, but the rotate speed is change quickly after a while.

280. Lamp that goes out but lights again(2)

Interchange the position of the 10K resistor and the loudspeaker. Remove the loudspeaker and install the photosensitive resistor, shield the photosensitive resistor from light by hand and then move hand away quickly, when there is light on the photosensitive resistor, the lamp goes out but lights after a while.



281. Instant stop lamp(2)

According to the diagram, replace the photosensitive resistor with the button switch, press the button switch, the lamp goes out but lights after a while.

282. Instant stop electric fan(2)

According to the diagram, replace the lamp with the electric fan, press the button switch, the rotate speed is slow down, it is change quickly after a while.

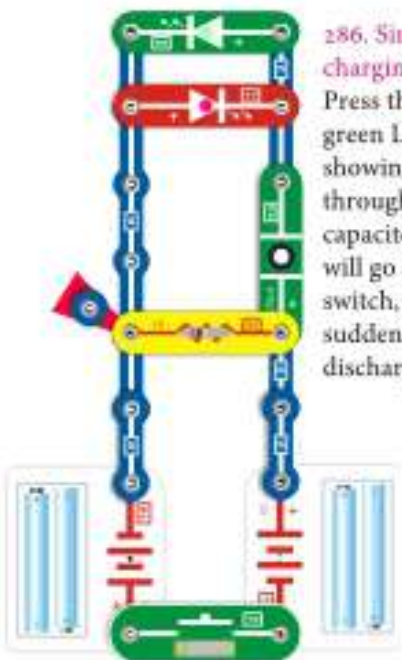

286. Simple way of electric charging and discharging

Press the button switch, only green LED lights suddenly, showing the current is flowing through the LED; after the capacitor is fully charged, LED will go out; turn off the button switch, only red LED will flash suddenly because of electricity discharging.

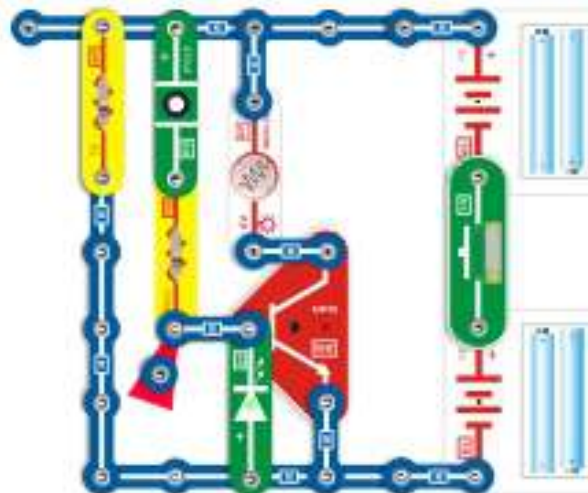

283. Electrical-optic gun

Press the button switch, the bulb flickers for a second; press again, the bulb flickers for another time; this circuit can be used in the electrical-optic gun.

284. One flashing Lamp

Switch off the 1K resistor and press the button switch, the bulb flickers for a second and goes out at once.

285. Lazy fan

Replace the bulb with a motor, press the button switch and the fan will be on for a few turns. press again after stop, and the fan will make a few more turns.

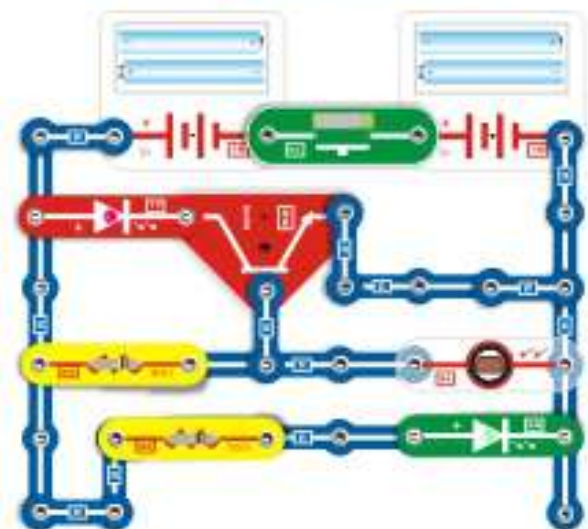

287. Electronic mail box reminder

Turn on the switch. If there is light on the photosensitive resistor, the red LED will not light. If shield the photosensitive resistor from light, the red LED will light. Using this principle, a simple mail box system can be made. Install the green LED and the photosensitive resistor inside the mailbox facing each other, when there is mail, the light is blocked from the photosensitive resistor and the red LED turns on.

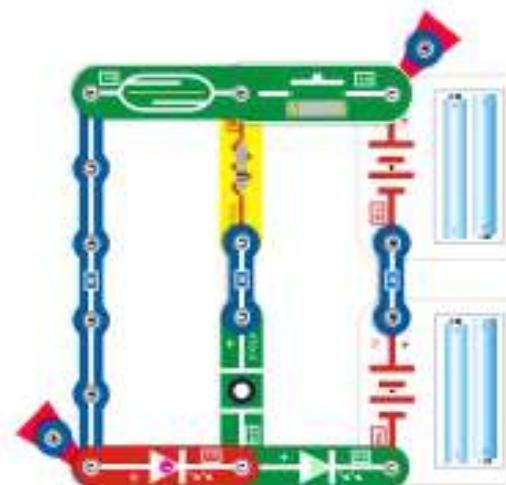

288. The charging and discharging of capacitor

Charging: Press the button switch, the battery will charge the capacitor via the resistor. The green LED lights suddenly, meaning the current is flowing through it; when the LED gradually becomes weaker in luminosity or even goes out, charging finished and release the button switch to cut off the current.

Discharging: Use the magnet to turn on the reed switch, the red LED lights and goes out after a while, indicating that the charged capacitor discharges electricity through the resistor and that there is discharging current flowing through the LED, but the discharge is completely discharged.

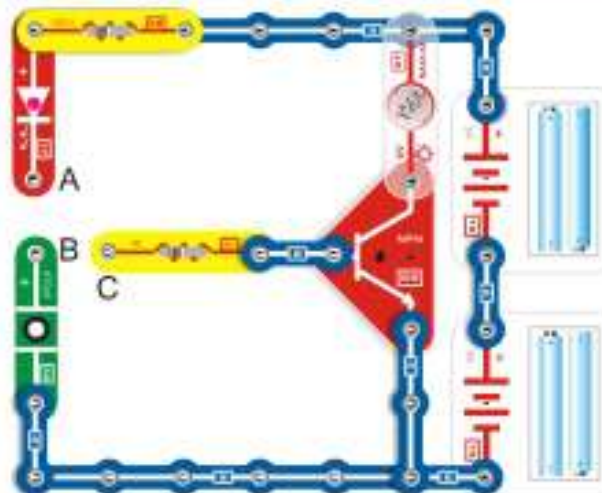

289. Power stored lamp
Build the circuit, connect the wire 2 to terminals A and B, the red LED will flash, meaning that the capacitor is being charged; remove the wire between A and B and connect it to terminals B and C, you can see the 6V bulb flashes when the capacitor discharges to the base of triode through the resistor.

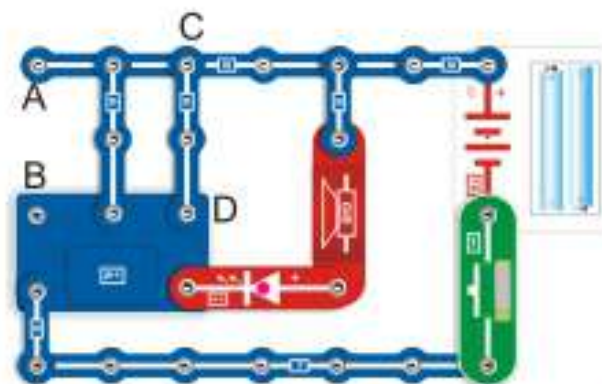

293. Soft music

Build the circuit and turn on the switch, the music plays and LED flickers along with the music.

294. Hand-controlled soft music

Replace the wire 3 between points C and D with a button switch, and after music stops, the soft music can be controlled by the hand.

295. Magnet-controlled soft music

Replace the wire 3 between points C and D with a reed switch, and after music stops, the soft music can be controlled by the magnet.

296. Sound-controlled time-delay soft music

Remove the wire 3 between points C and D,

connect the buzzer with points A and B, after music stops, it will play again if clapping or yelling, and stops after playing a song; and the LED lights at the same time.

297. Motor-activated time-delay soft music

Remove the wire 3 between points C and D, connect the motor with points A and B; after music stops, the light music will sound again if turning the shaft of the motor slightly, and stops after playing a song.

298. Light-controlled soft music

Replace the wire 3 between points C and D with a photosensitive resistor, and after music stops, the soft music can be controlled by the light.

299. Water-controlled soft music

Replace the wire 3 between points C and D with a touch plate, and after music stops, when water drops on the touch plate, the music will play again and LED lights at the same time.

Question: Remove the wire 3 between points C and D, connect points A and B, how about it?

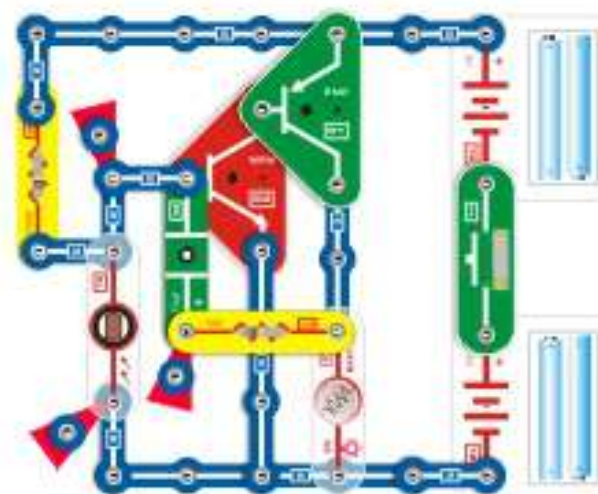

290. Automatic navigation lamp

At night, navigation lamps in rivers can automatically light up. With dawn coming, they will go out automatically. As shown in the diagram, turn on the switch, if there is light on the photosensitive resistor, the lamp will not light. If you shield the photosensitive resistor from light by hand, the bulb will light automatically.

291. Simple metronome

Remove the photosensitive resistor and replace the bulb with the loudspeaker. When the switch is turned on, the loudspeaker will produce sound at a given rhythm.

292. Flashing bulb

Remove the photosensitive resistor and turn on the switch, the bulb will flash.

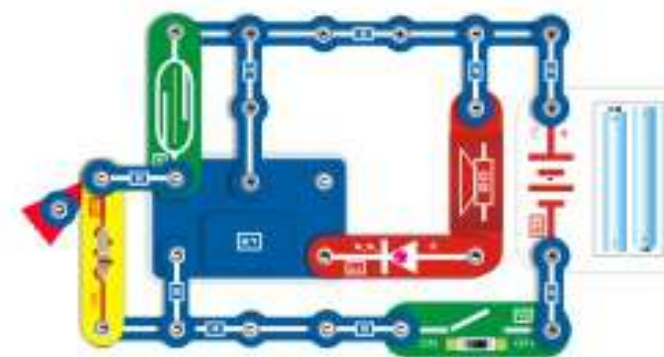

300. Magnet-controlled time-delay soft music

Build the circuit and turn on the switch, after music stops, turn on the reed switch by magnet and removing it, the light music will sound again and stop after playing a song.

301. Hand-controlled time-delay soft music

Replace the reed switch with a button switch, after music stops, press the button switch and release it, the light music will sound again and stop after playing a song.

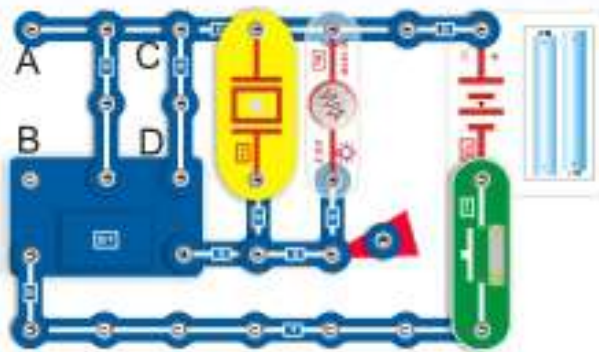

302. Acousto-optic buzzer music doorbell

Build the circuit and turn on the switch. The buzzer plays music and the lamp lights at the same time.

303. Hand-controlled sound of music give outted by an acousto-optic buzzer

Replace the wire 3 between points C and D with a button switch; when music stops, you may use the button switch to control the sound of music.

304. Magnet-controlled sound of music give outted by an acousto-optic buzzer

Replace the wire 3 between points C and D with a reed switch; when the music stops, you may use a magnet to control the sound of music.

305. Light-controlled sound of music give outted by an acousto-optic buzzer

Replace the wire 3 between points C and D with a photosensitive resistor and then you may use the light to control the sound of music.

306. Water-controlled sound of music give outted by an acousto-optic buzzer

Replace the wire 3 between points C and D with a touch plate and then you may use the water drop to control the sound of music.

307. Motor-controlled sound of music give outted by an acousto-optic buzzer with a time delay

Remove the wire 3 between points C and D and connect the motor to points A and B; after music stops, the music will be played again as long as you turn the shaft of the motor slightly, and the lamp will light at the same time for a while before going out.

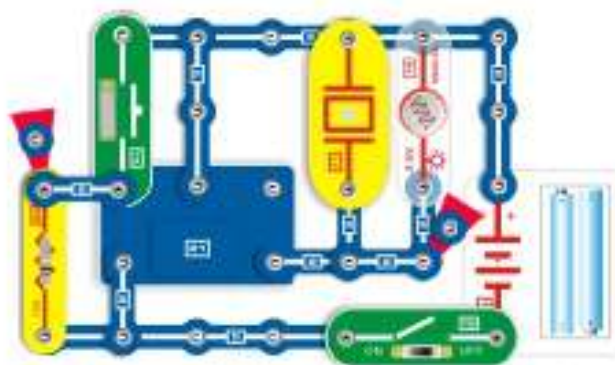

308. Hand-controlled sound of music give outted by an acousto-optic buzzer with a time delay

Turn on the switch and the music will stop after a while. When you press the button switch, the music will be played again and the lamp will light at the same time, which will stay on for a while before going out.

309. Magnet-controlled sound of music give outted by an acousto-optic buzzer with a time delay

Replace the button switch with a reed switch. When the music stops, turn on the reed switch by magnet and the music will be played again; the lamp will light at the same time, which will stay on for a while before going out.

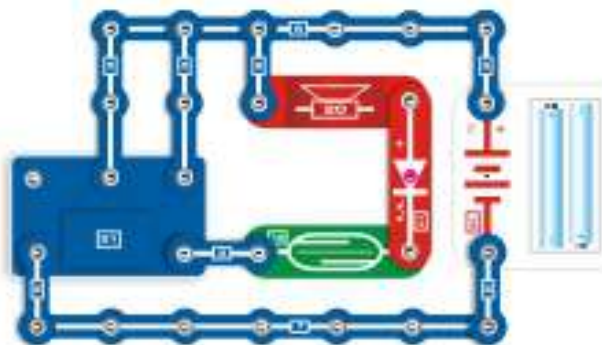

310. Hand-controlled intermittent acousto-optic buzzer doorbell

Build the circuit, press the button switch according to certain rhythm, the buzzer will give out the intermittent music, and the bulb intermittent flicker at the same time.

311. Magnet-controlled intermittent acousto-optic buzz doorbell

Replace the button switch with a reed switch, move the magnet above the reed switch back and forth, the buzzer will give out the intermittent music, and the bulb intermittent shines at the same time.

312. Magnet-controlled intermittent soft music

Build the circuit, move the magnet above the reed switch back and forth, the loudspeaker will give out the intermittent light music.

313. Hand-controlled intermittent soft music

Replace the reed switch with a button switch, press the button switch according to certain rhythm, the loudspeaker will give out the intermittent light music.

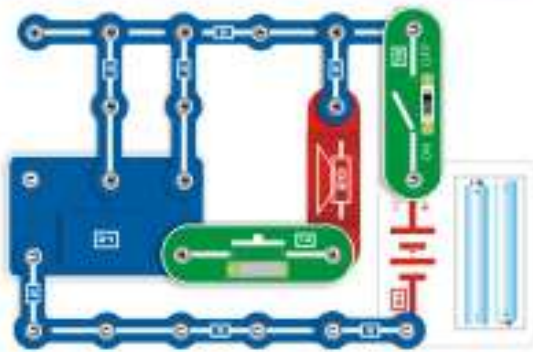

314. Hand-controlled intermittent music doorbell

Turn on the switch, press the button switch according to certain rhythm, the loudspeaker will give out the intermittent music doorbell.

315. Magnet-controlled intermittent music doorbell

Replace the button switch with a reed switch, move the magnet above the reed switch back and forth, the loudspeaker will give out the intermittent music doorbell.

Question: Replace switch with a photosensitive resistor, can it become light-controlled intermittent music doorbell? Why?

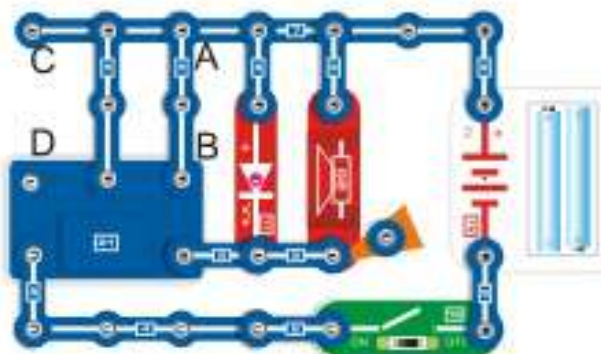

316. Color lamp doorbell

Turn on the switch, the loudspeaker will give out the music and LED flickers at the same time.

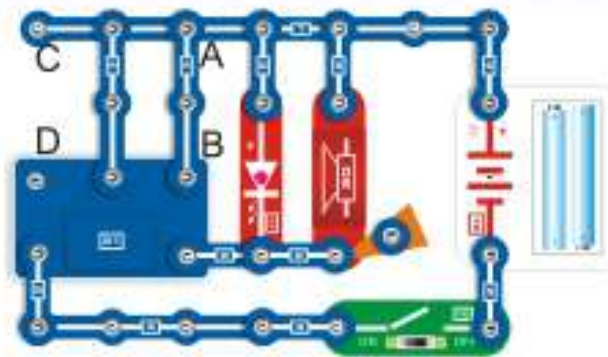

317. Light-controlled color lamp doorbell

Replace the wire 3 between points A and B with a photosensitive resistor, and music color lamp doorbell can be controlled by the light.

318. Water-controlled color lamp doorbell

Replace the wire 3 between points A and B with a touch plate, and music color lamp doorbell can be controlled by the water.

319. Magnet-controlled color lamp doorbell

Replace the wire 3 between points A and B with a reed switch, and music color lamp doorbell can be controlled by the magnet.

320. Hand-controlled color lamp doorbell

Replace the wire 3 between points A and B with a button switch, and music color lamp doorbell can be controlled by the hand.

321. Sound-controlled time-delay color lamp doorbell

Remove the wire 3 between points A and B, connect the buzzer with points C and D, after music stops, it will play again if clapping or yelling, and the LED lights at the same time and stays on for a while before going out.

322. Motor-activated time-delay color lamp doorbell

Remove the wire 3 between points A and B, connect the motor with points C and D, after music stops, it will play again if turning the shaft of the motor, and the LED lights at the same time and stays on for a while before going out.

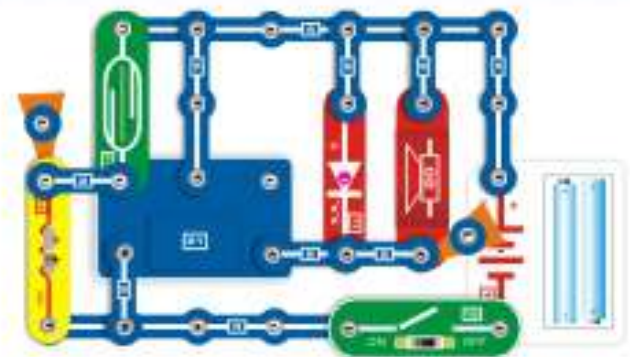

323. Magnet-controlled time-delay color lamp doorbell

Turn on the switch, after music stops, it will play again if turn on the reed switch by magnet, and the lamp lights at the same time and stays on for a while before going out.

324. Hand-controlled time-delay color lamp doorbell

Replace the reed switch with a button switch, after music stops, it will play again if pressing the button switch, and the lamp lights at the same time and stays on for a while before going out.

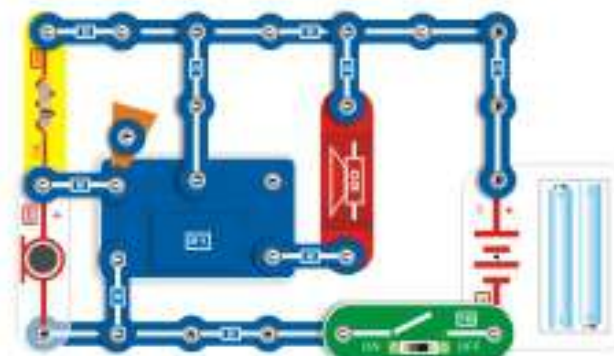

325. High-sensitivity sound-controlled music doorbell

Turn on the switch, after the music stops, it will be played again by clapping hands or whistling a few feet away; the sensitivity of it is higher than buzzer.

326. High-sensitivity sound-controlled lamp with a time delay

Replace the loudspeaker with a 2.5V bulb, turn on the switch and after lamp goes out, it will light again by clapping hands or whistling a few feet away, and will stay on for a while before going out.

327. High-sensitivity sound-controlled LED with time delay

Replace the loudspeaker with LED, turn on the switch and after lamp goes out, LED will light again by clapping hands or whistling a few feet away, and will stay on for a while before going out.

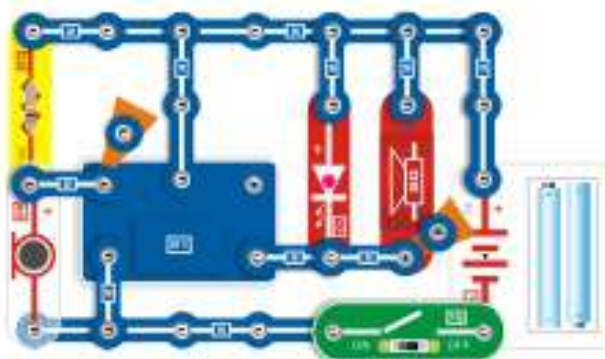

328. High-sensitivity sound-controlled doorbell with color lamp

Turn on the switch and after music stops, it will play again by clapping hands or whistling a few feet away, the LED lights at the same time and it will stay on for a while before going out.

329. High-sensitivity sound-controlled delay double flashing lamp

Replace the loudspeaker with a 2.5V bulb, turn on the switch and after lamp and LED goes out, they will light again by clapping hands or talking loudly a few feet away, and will stay on for a while before going out.

330. High-sensitivity sound-controlled acousto-optic doorbell

Replace the loudspeaker with a 2.5V bulb and the LED with a buzzer, turn on the switch and after the lamp goes out, the music will play again by clapping hands or whistling a few feet away, and the lamp will stay on for a while before going out.

331. High-sensitivity sound-controlled soft music

Connect the LED and the loudspeaker in series (the anode of LED is connected with the anode of power supply of the circuit), and turn on the switch; after music stops, the soft music will play again by clapping hands or whistling a few feet away.

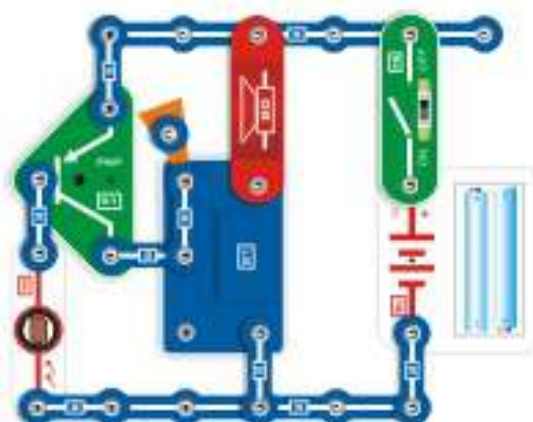

332. Dawn light-controlled sound of music

Turn on the switch. If there is light on the photosensitive resistor, sound of music will be given on. If you shield the photosensitive resistor from light by hand, the music will stop.

333. Dawn light-controlled flashing lamp

Replace the loudspeaker with a 2.5V bulb and you can control the lamp in the same way as above.

334. Dawn light-controlled flashing LED

Replace the loudspeaker with the LED and you can control the LED in the same way as above.

335. Dawn light-controlled sound of music motor

Replace the loudspeaker with the motor and you can control the motor in the same way as above.

Question: Replace the PNP with the NPN, is it ok?



336. Dawn light-controlled double flashing lamps

Turn on the switch. If there is light on the photosensitive resistor, the bulb and LED will light at the same time. If you shield the photosensitive resistor from the light by hand, the bulb and LED will go out at the same time.

337. Dawn light-controlled sound of acousto-optic doorbell

Replace the LED with the buzzer; you can control the acousto-optic doorbell in the same way as above.

338. Dawn light-controlled sound of color lamp doorbell

Replace the bulb with the loudspeaker and keep the LED; you can control the color lamp doorbell in the same way as above.

339. Dawn light-controlled light music

Install the circuit, turn on the switch at night and there is no music. With dawn coming, when there is light on the photosensitive resistor, the loudspeaker will give out light music and the LED will be flashing.



340. Darkness-controlled light music

Turn on the switch, with the night coming or shield the photosensitive resistor from light by hand, the loudspeaker will give out music.

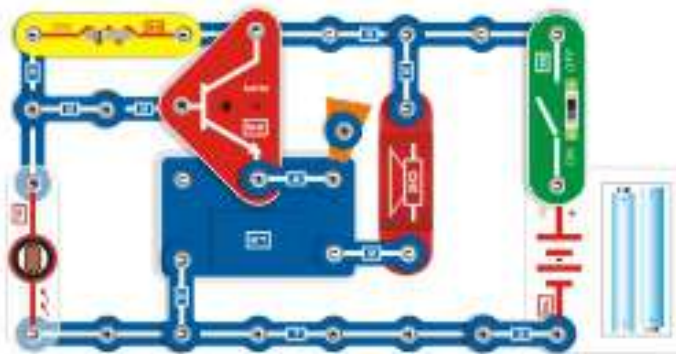

341. Darkness reminder

Turn on the switch, when it is dark or shield the photosensitive resistor from light by hand, the loudspeaker will produce music. This circuit may be used for darkness alarm.

342. Darkness-controlled LED

Replace the loudspeaker with LED. When it is dark, the LED will light.



345. Darkness-controlled sound of color lamp doorbell

Turn on the switch. When it is dark or shield the photosensitive resistor from light by hand, the loudspeaker will give out sound of doorbell ring, and the LED will light at the same time.

346. Darkness-controlled of double color flashing lamp

Replace the loudspeaker with the green LED. When it is dark, the red and green LEDs will flash the color gleam.



347. Red-green flashing lamp

Turn on the switch, the red-green LED shows color light. It stop after a time delay and intermittently flashes until the power is cut off.

348. Magnet-controlled red-green flashing lamp

Replace the wire 3 between points C and D with a reed switch, place the magnet close to the reed switch, the color lamp flickers; remove the reed switch, the color lamp goes out.

349. Light-controlled red-green flashing lamp

Replace the wire 3 between points C and D with a

photosensitive resistor, and the double color lamp can be controlled by the light.

350. Water-controlled red-green flashing lamp

Replace the wire 3 between points C and D with a touch plate, and the double color lamp can be controlled by the water.

351. Hand-controlled red-green flashing lamp

Replace the wire 3 between points C and D with a button switch, and the double color lamp can be controlled by the hand.

352. Sound-controlled red-green flashing lamp with time delay

Remove the wire 3 between points C and D, connect the buzzer with points A and B, after color lamp goes out, it will flicker again if clapping or yelling.

353. Motor-controlled red-green flashing lamp with time delay

Remove the wire 3 between points C and D, connect the motor to points A and B, and the double color lamp can be controlled by the electricity.

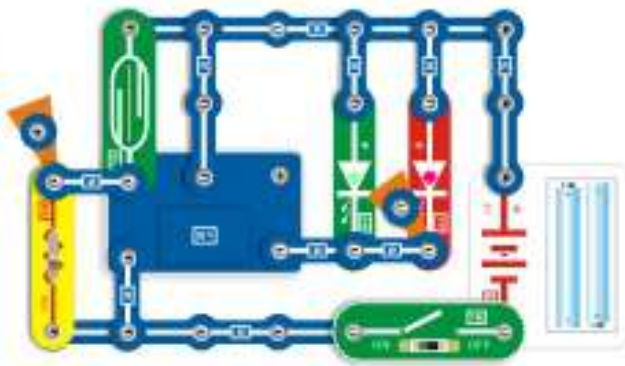

354. Magnet-controlled red-green flashing lamp with time delay

Turn on the switch, after color lamp goes out, turn on the reed switch by magnet, the lamp will flicker again and go out after a while.

355. Hand-controlled red-green lamp with time delay

Replace the reed switch with a button switch, and the color lamp can be controlled by the hand.

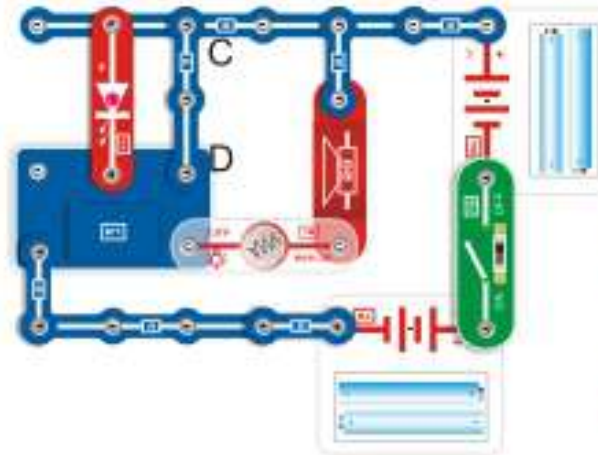

356. Sound & doorbell with medium pitch sound

Turn on the switch, the loudspeaker plays the doorbell and the bulb flashes; the sound is louder than original one; it is a doorbell with medium pitch sound.

357. Magnet-controlled acousto-optic doorbell with medium pitch sound

Replace the wire 3 between points C and D with a reed switch, and the acousto-optic doorbell with medium pitch sound can be controlled by the magnet.

358. Light-controlled acousto-optic doorbell with medium pitch sound

Replace the wire 3 between points C and D with a photosensitive resistor, and the acousto-optic doorbell with medium pitch sound can be controlled by the light.

359. Water-controlled acousto-optic doorbell with medium pitch sound

Replace the wire 3 between points C and D with a touch plate, and the acousto-optic doorbell with medium pitch sound can be controlled by the water drop.

360. Hand-controlled acousto-optic doorbell with medium pitch sound

Replace the wire 3 between Points C and D with a button switch, and the acousto-optic doorbell with medium pitch sound can be controlled by the hand.

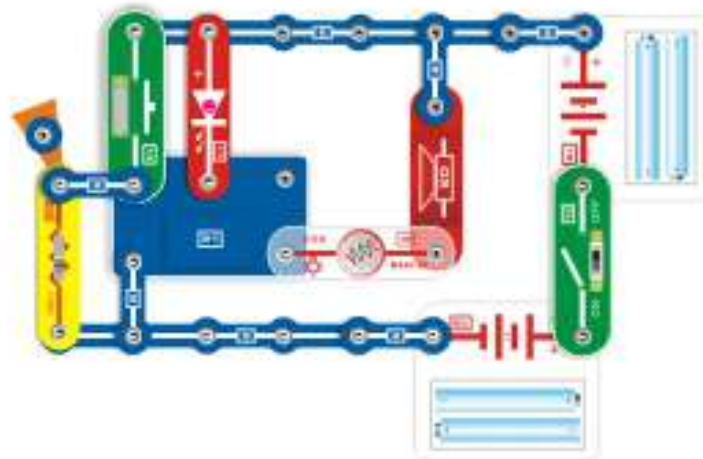

361. Hand-controlled acousto-optic doorbell with medium pitch sound and time delay

Turn on the switch, after music stops, the acousto-optic doorbell with medium pitch sound can be controlled by the button switch, and can stay on for a while before stopping.

362. Magnet-controlled acousto-optic doorbell with medium pitch sound and time delay

Replace the button switch with a reed switch, after music stops, turn on the reed switch by magnet and the music will play again.

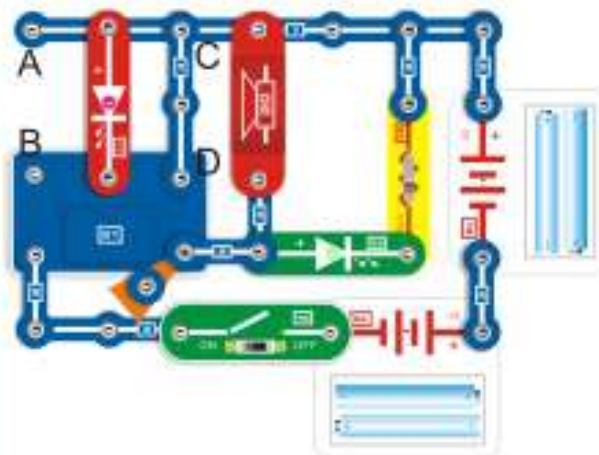

363. Doorbell with color lamp and high pitch sound

Turn on the switch, the loudspeaker plays doorbell with high pitch sound and the LED flashes.

364. Light-controlled doorbell with color lamp and high pitch sound

Replace the wire 3 between points C and D with a photosensitive resistor, and the doorbell with high pitch sound can be controlled by the light.

365. Water-controlled doorbell with color lamp and high pitch sound

Replace the wire 3 between points C and D with a touch plate, and the doorbell with high pitch sound can be controlled by the water.

366. Hand-controlled doorbell with color lamp and high pitch sound

Replace the wire 3 between points C and D with a button switch, and the doorbell with high pitch sound can be controlled by the hand.

367. Magnet-controlled doorbell with color lamp and high pitch sound

Replace the wire 3 between points C and D with a reed switch, and the doorbell with high pitch sound can be controlled by the magnet.

368. Sound-controlled doorbell with color lamp

and high pitch sound

Remove the wire 3 between points C and D, connect the buzzer with points A and B; after music stops, the music will sound again if clapping hands or yelling, and the LED will flash.

369. Motor-controlled doorbell with color lamp and high pitch sound

Remove the wire 3 between points C and D, connect the motor with points A and B, and the doorbell with high pitch sound can be controlled by the electricity.

Question: Connect the microphone to points A and B, can it become sound-controlled?

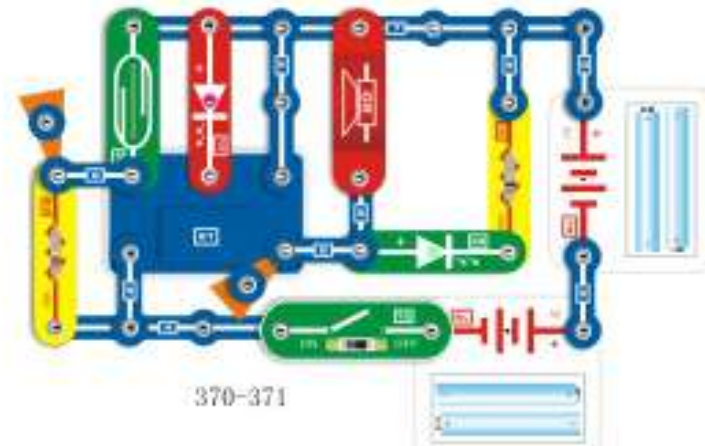

370-371

370. Magnet-controlled time-delay doorbell with color lamp and high pitch sound

Turn on the switch, after the high pitch sound stops, the doorbell with high pitch sound will sound again if turn on the reed switch by the magnet, and the color lamp will light and stay on for a while before stopping.

371. Hand-controlled time-delay doorbell with color lamp and high pitch sound

Replace the reed switch with a button switch, press the button switch and the music integrated circuit will be activated, and the music will play again.

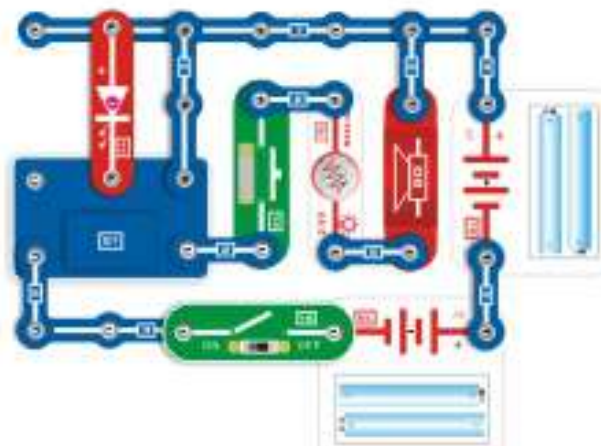

372. Hand-controlled intermittent acousto-optic doorbell with medium pitch sound

Turn on the switch, press the button switch according to certain rhythm, the loudspeaker will play intermittent sound of doorbell with medium pitch sound, and the bulb will flash.

373. Magnet-controlled intermittent acousto-optic doorbell with medium pitch sound

Replace the button switch with a reed switch, move the magnet on the reed switch back and forth, the loudspeaker will play intermittent sound of doorbell with medium pitch sound, and the bulb will flash intermittently.

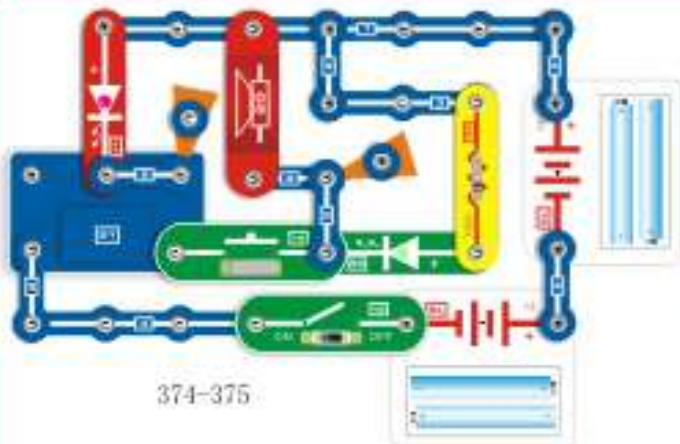

374-375

374. Hand-controlled intermittent doorbell with color lamp and high pitch sound

Turn on the switch, press the button switch according to certain rhythm, the loudspeaker will play intermittent sound of doorbell with high pitch sound, and the bulb will flash intermittently.

375. Magnet-controlled intermittent doorbell with color lamp and high pitch sound

Replace the button switch with a reed switch, and the doorbell with color lamp and high pitch sound can be controlled by the magnet.

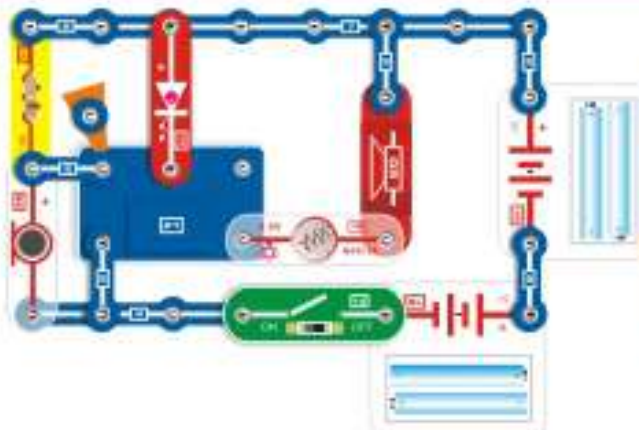

377. High-sensitivity sound-controlled acousto-optic doorbell with medium pitch sound

Turn on the switch and wait until the music stops. Clap or whistle a few feet away and the music plays again and bulb lights up at the same time.

378. High-sensitivity sound-controlled doorbell with high pitch sound

Replace the 2.5V bulb with the wire 3 and the doorbell with high pitch sound can be controlled by the sound.

Question: Is it ok if replace the 10k resistor to 100 Ω resistor?



379. Light-activated red-green color lamp

Turn on the switch, when there is light on the photosensitive resistor, the color lamp lights; shield the photosensitive resistor from light, the color lamp goes out.



376. High-sensitivity sound-controlled red-green double color lamp

Turn on the switch, red-green double color lamp flashes and wait until the light goes out. Clap or whistle a few feet away, the color lamp lights again.

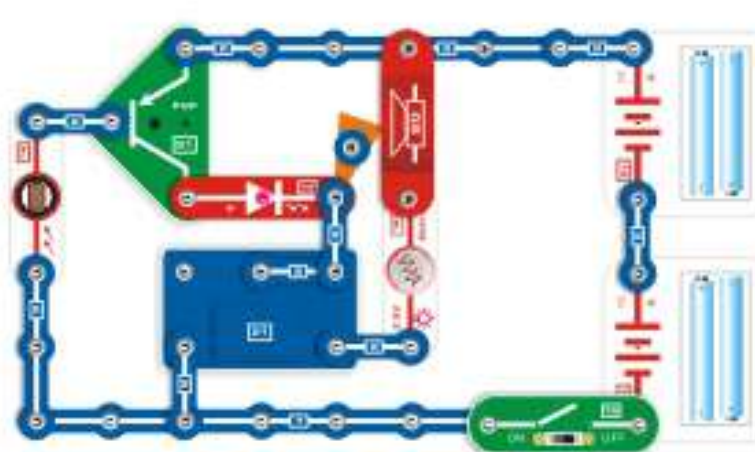

380. Light-activated acousto-optic doorbell with medium pitch sound

Turn on the switch, when there is light on the photosensitive resistor, the doorbell sounds and lamp lights; shield the photosensitive resistor from light, the doorbell stops and lamps goes out.

381. Daybreak-activated doorbell with high pitch sound

Replace the 2.5V bulb by wire 3, turn on the switch at night, when daybreak in the next day, the loudspeaker gives out loud doorbell with high pitch sound, hurrying you to get up.



382. Sad birthday blessing

Turn on the switch, the loudspeaker gives out slow music like playing a sad birthday blessing.

Question: What will happen if replacing the 10k resistor with smaller resistor?



383. Lazy music

Turn on the switch and photosensor gives out lazy music.

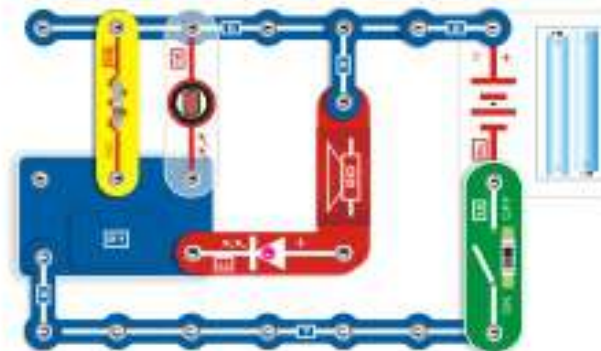

384. Motor birthday candle

Place the circuit in a dark room, turn on the switch and place the birthday cake aside; when lighting the birthday candle in the cake, the birthday music plays at once and will not stop until the candle is puffed out by the person whose birthday is being celebrated.



385. Day break-activated lazy alarm clock

In the night, turn on the switch, when day breaks in the next day, the loudspeaker gives out lazy music, reminding you of getting up.

386. Gentle blessing at dark

Interchange the positions of 100K resistor and the photosensitive resistor, then place this circuit in the room; at night, the circuit plays gentle blessing sound in darkness.

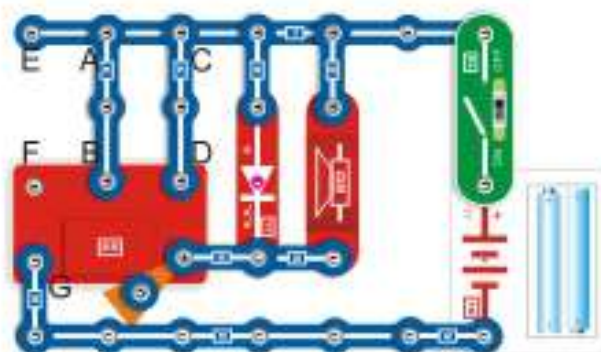

387. Red light warning sound of police wagon

Turn on the switch, the loudspeaker gives out the sound of police wagon, and LED gives out the warning of red light to show reality.

388. Red light warning sound of machine gun

Just connect C to D and A to B respectively.

389. Red light warning sound of fire engine

Just connect E to F and A to B respectively.

390. Red light warning sound of ambulance

Just connect A to B and F to G respectively.

391. Red light warning sound of Buddha laugh

Just connect A to B and D to F respectively.

392. Magnet-controlled red light warning sound of police wagon

393. Magnet-controlled red light warning sound of machine gun

394. Magnet-controlled red light warning sound of fire engine

395. Magnet-controlled red light warning sound of ambulance

396. Magnet-controlled red light warning sound of Buddha laugh

392-396: Connect according the connection methods of 387-391, then replace the switch with a reed switch, and the above 5 sounds can be controlled by the magnet.

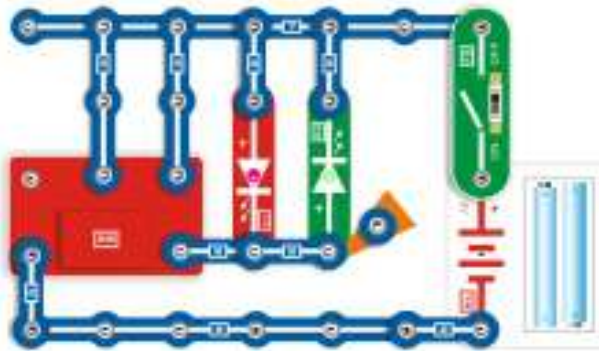

397. Flashing red-green double alarm lamps

Turn on the switch, the red and green LEDs light and go out repeatedly.

398. Magnet-controlled flashing red-green double alarm lamps

Replace the switch with a reed switch, place the magnet close to the reed switch, the red and green LEDs flickers at the same time.

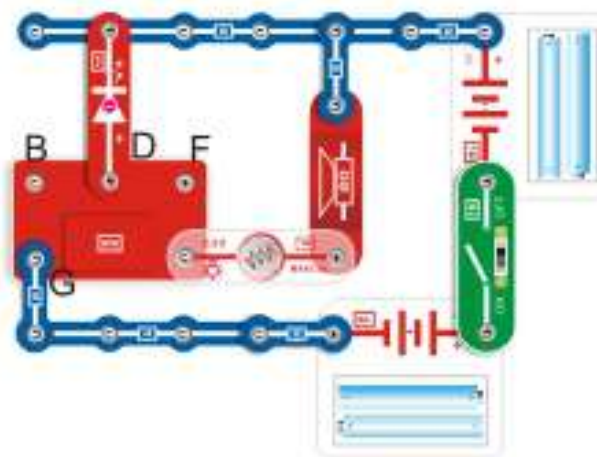

403. Acousto-optic low pitch sound of Buddha laugh

Just need to connect C to D and B to F separately.

404. Magnet-controlled acousto-optic low pitch sound of police wagon

405. Magnet-controlled acousto-optic low pitch sound of machine gun

406. Magnet-controlled acousto-optic low pitch sound of fire engine

407. Magnet-controlled acousto-optic low pitch sound of ambulance

408. Magnet-controlled acousto-optic low pitch sound of Buddha laugh

404-408: According to the connection method of 399-403, replace the switch with a reed switch, the above 5 sounds can be controlled by the magnet.

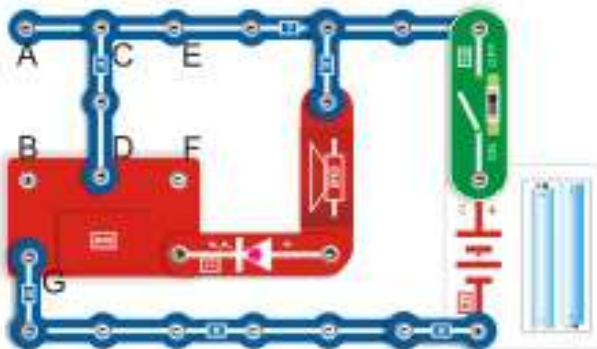

399. Acousto-optic low sound of police wagon

Turn on the switch, the loudspeaker gives out a low pitch sound of police wagon and the LED lights at the same time.

400. Acousto-optic low pitch sound of machine gun
Just need to connect C to D and E to F separately.

401. Acousto-optic low pitch sound of fire engine
Just need to connect C to D and A to B separately.

402. Acousto-optic low pitch sound of ambulance
Just need to connect C to D and B to G separately.

409. Acousto-optic medium pitch sound of police wagon
Turn on the switch, the loudspeaker gives out medium pitch sound of police wagon, and the bulb lights.

410. Acousto-optic medium pitch sound of machine gun
Just need to connect D to F.

411. Acousto-optic medium pitch sound of fire engine
Just need to connect B to D independently.

412. Acousto-optic medium pitch sound of ambulance
Just need to connect B to G independently.

413. Acousto-optic medium pitch sound of Buddha laugh

Just need to connect B to F independently.

414. Magnet-controlled acousto-optic medium pitch sound of police wagon

415. Magnet-controlled acousto-optic medium pitch sound of machine gun

416. Magnet-controlled acousto-optic medium pitch sound of fire engine

417. Magnet-controlled acousto-optic medium pitch sound of ambulance

418. Magnet-controlled acousto-optic medium pitch sound of Buddha laugh

414-418: According to the connection method of 409-413, replace the switch with a reed switch, the above 5 sounds can be controlled by the magnet.

Question: How about it if replacing the red LED with 2.5v bulb?



419. Amplified sound of police wagon
Turn on the switch, the loudspeaker plays the amplified sound of police wagon.

420. Amplified sound of machine gun
Just need to connect C to D and E to F.

421. Amplified sound of fire engine
Just need to connect C to D and A to B.

422. Amplified sound of ambulance
Just need to connect C to D and B to G.

423. Amplified Sound of Buddha laugh
Just need to connect C to D and B to F.

424. Amplified sound of light machine gun
Just need to connect C to D and F to H.

425. Amplified sound of heavy machine gun
Connect F to H independently.

426. Amplified sound of clash
Just need to connect F to H and B to G.

427. Magnet-controlled amplified sound of police wagon

428. Magnet-controlled amplified sound of machine gun

429. Magnet-controlled amplified sound of fire engine

430. Magnet-controlled amplified sound of ambulance

431. Magnet-controlled amplified Sound of Buddha laugh

432. Magnet-controlled amplified sound of light machine gun

433. Magnet-controlled amplified sound of heavy machine gun

434. Magnet-controlled amplified sound of whomp

427-434: According to the connection method of 419-426, replace the switch with a reed switch, the above 8 sounds can be controlled by the magnet.

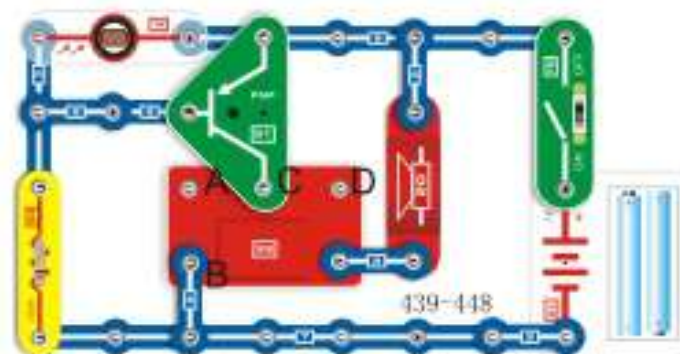

439. Dark activated alarming sound of police wagon
Turn on the switch, when at dark, the loudspeaker gives out the sound of police wagon.

440. Dark activated alarming sound of machine gun
Just connect C to D alone.

441. Dark activated alarming sound of fire engine
Just connect A to C alone.

442. Sound of ambulance that alarms at dark
Just connect A to B alone.

443. Dark activated alarming sound of Buddha laugh
Just connect A to D alone.

444. Sound of police wagon that fears the magnet

445. Sound of machine gun that fears the magnet

446. Sound of fire engine that fears the magnet

447. Sound of ambulance that fears the magnet

448. Sound of Buddha laugh that fears the magnet

444-448: According to the connection methods of 439-443, replace the photosensitive resistor with a reed switch, the sound will stop once when place the magnet close to the reed switch.

Question: Is it ok if replace the 100k resistor with wire 3?

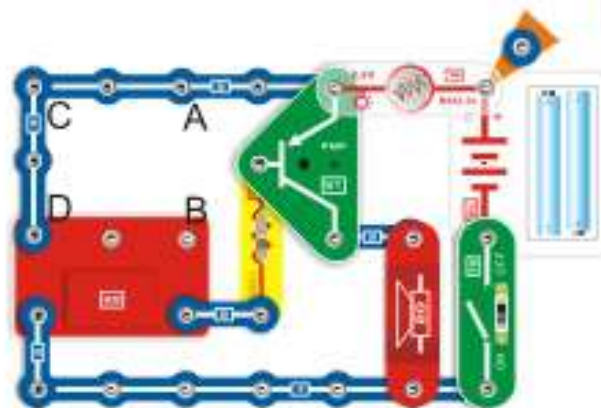

435. Amplified sound of game machine
Turn on the switch, the loudspeaker plays the amplified sound of game machine (the bulb does not light here is designed special to achieve stable sound of game machine).

436. Amplified slow sound of machine gun
Connect the wire 3 from between points C and D to between points A and B, and the loudspeaker plays slow sound of machine gun.

437. Magnet-controlled amplified sound of game machine

Replace the switch with a reed switch, and the sound of game machine can be controlled by the magnet.

438. Magnet-controlled amplified slow sound of machine gun

Connect the wire 3 from between points C and D to between points A and B, and replace the switch with a reed switch, the slow sound of machine gun can be controlled by the magnet.

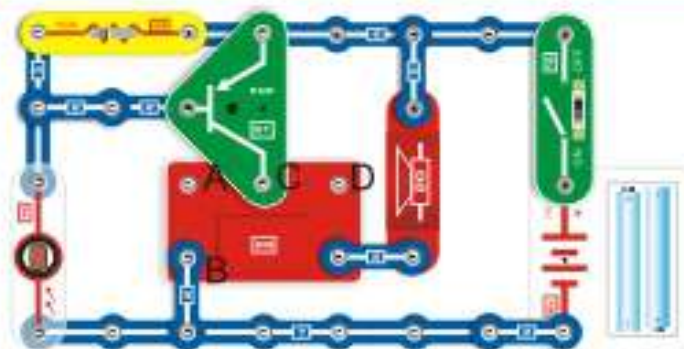

449. Dawn light-activated alarming sound of police wagon
Turn on the switch when it get dark and the loudspeaker makes no sound. With dawn coming, the loudspeaker will give out sound of police wagon.

450. Dawn light-activated alarming sound of machine gun
Only connect Points C to D alone.

451. Dawn light-activated alarming sound of fire engine
Only connect A to C alone.

452. Dawn light-activated alarming sound of ambulance
Only connect points A to B alone.

453. Dawn light-activated alarming sound of Buddha laugh
Only connect A to D together.

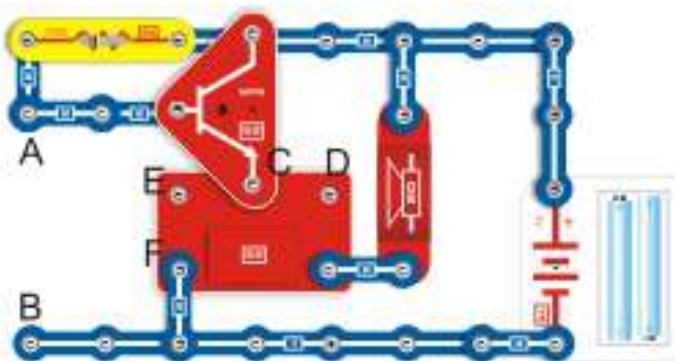

459. Anti-theft sound of police wagon activated by wire breaking(1)

Built the circuit and the loudspeaker will give out alarming sound of police wagon. If points A and B are connected by a wire, the alarming sound will stop. For anti-theft, a long thin wire may be used to thread through bicycle, motorcycle, car, door, window, etc. Then connect the ends of the thin wire to points A and B. If a burglar breaks the

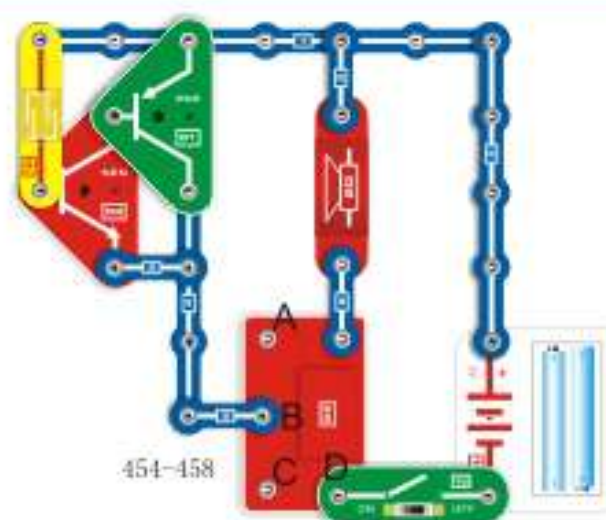

454. Combined-transistors touch-controlled sound of police wagon

Turn on the switch and touch the touch plate, the loudspeaker will play the sound of police wagon.

455. Combined-transistors touch-controlled sound of machine gun

Connect A to B independently, and touch the touch plate, the loudspeaker will play the sound of machine gun.

456. Combined-transistors touch-controlled sound of fire engine

Connect B to C independently, and touch the touch plate, the loudspeaker will play the sound of fire engine.

457. Combined-transistors touch-controlled sound of ambulance

Connect C to D independently, and touch the touch plate, the loudspeaker will play the sound of ambulance.

458. Combined-transistors touch-controlled sound of Buddha laugh

Connect A to C independently, and touch the touch plate, the loudspeaker will play the sound of Buddha laugh.

wire, the loudspeaker will give out alarming sound of police wagon.

460. Anti-theft sound of machine gun activated by wire breaking(1)
Only connect points C to D.

461. Anti-theft sound of fire engine activated by wire breaking(1)
Only connect E to C.

462. Anti-theft sound of ambulance activated by wire breaking(1)
Only connect E to F.

463. Anti-theft sound of Buddha laugh activated by wire breaking(1)
Only connect E to D.

464. Anti-theft alarming flash LED activated by wire breaking(1)

Connect points C to D and replace the loudspeaker with the 2.5V bulb, and then connect points A to B by a thin wire. If a burglar breaks the thin wire, the LED will light for alarming.

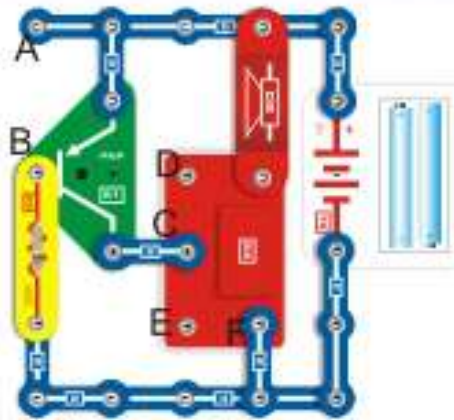

465. Anti-theft sound of police wagon activated by wire breaking(2)
 466. Anti-theft sound of machine gun activated by wire breaking(2)
 467. Anti-theft sound of fire engine activated by wire breaking(2)
 468. Anti-theft sound of ambulance activated by wire breaking(2)
 469. Anti-theft sound of Buddha laugh activated by wire breaking(2)
 470. Anti-theft alarming flash LED activated by wire breaking(2)
 The operation and connection mode of 434-439 are the same as those of 426-433. The difference is that these circuits adopt PNP triode to control.

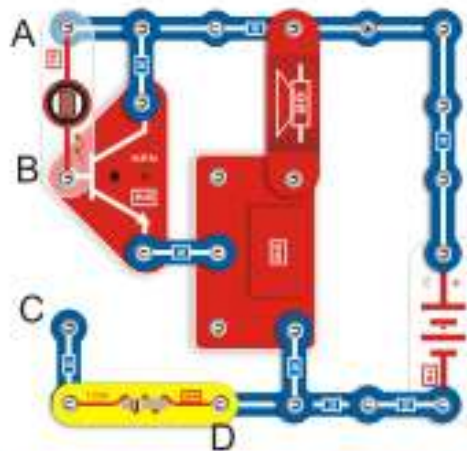

471. Light-controlled anti-theft alarm(1)
 Install the circuit. Place it in darkness after you turn off the lamp at night. If a burglar enters the room and strikes light, the loudspeaker will give out alarming sound immediately.
 472. Light-controlled anti-theft alarming lamp(1)
 Replace the loudspeaker with LED. If there is light, the LED will light immediately for alarming.
 473. Magnet-controlled anti-theft alarm(1)
 Install the loudspeaker back to its initial position.

Then install reed switch and magnet to the doorframe and door respectively. Make sure that when the door is close, the reed switch will turn on. Then lead the ends of the reed switch out by wires and connect the wires to the points B and D of the circuit. Once a burglar opens the door, the loudspeaker will give out alarming sound immediately.

474. Magnet-controlled anti-theft alarm lamp(1)
 Replace the loudspeaker with LED. Once a burglar opens the door, the LED will light immediately for alarming.
 475. Light-controlled anti-theft alarm(2)
 Replace the NPN triode with the PNP triode and connect the photosensitive resistor to points B and C instead. If there is light, the loudspeaker will give out alarming sound immediately.
 476. Light-controlled anti-theft alarm lamp(2)
 Replace the loudspeaker with the LED. Once a burglar opens the door, the LED will light immediately for alarming.
 477. Magnet-controlled anti-theft alarm(2)
 Install the reed switch and magnet to the doorframe and door respectively. Make sure that when the door is close, the reed switch will turn on. Then lead the reed switch out by wires and connect the wires to points A and B. Once a burglar open the door, the loudspeaker will give out alarming sound immediately.
 478. Magnet-controlled anti-theft alarm lamp(2)
 Replace the loudspeaker with LED. If a burglar open the door, the LED will light immediately for alarming.



479. Alarming sound of patrol wagon with time delay
 Turn on the switch. Press the button then release. The loudspeaker will give out sound of patrol wagon and stays on for a while before stop.
 480. Alarming sound of machinegun with time delay
 Connect A to B. The rest operations are the same as above.
 481. Alarming sound of fire machine with time delay
 Connect B to C. The rest operations are the same as above.
 482. Alarming sound of ambulance with time delay
 Connect C to D. The rest operations are the same as above.
 483. Alarming sound of Buddha laugh with time delay
 Connect A to C. The rest operations are the same as above.
 484. Magnet-controlled sound of patrol wagon with time delay
 485. Magnet-controlled sound of machinegun with time delay
 486. Magnet-controlled sound of fire machine with time delay
 487. Magnet-controlled sound of ambulance with time delay
 488. Magnet-controlled sound of Buddha laugh with time delay
 484-488. According to line way of 479-483. Replace the button switch with the reed switch, above five sounds with time delay can be controlled by magnet.



489. Funny police wagon sound of game machine

Turn on the switch, the loudspeaker gives out the sound of police wagon, then press the button switch, you will find that there are many funny game machine sounds among the sound of police wagon, release the button switch, and the sound of police wagon will sound again.

490. Magnet-controlled funny police wagon sound of game machine

Replace the button switch with a reed switch, and the sound of police wagon can be controlled by the magnet.

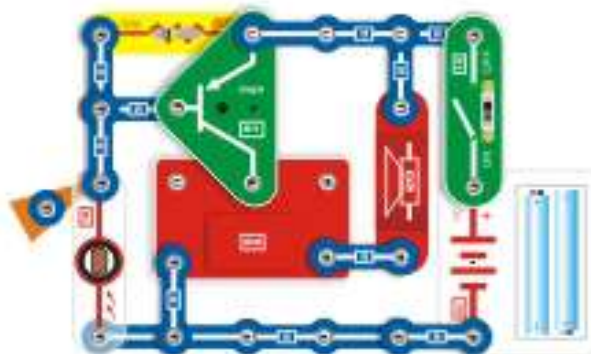

491. Urging device for lamp switching off

Build the circuit in a room where timely lamp switching off is requested (for example collective dormitory or hostel). Lead the switch in the circuit to the duty room of the administrator by use of two thin wires. At the time of lamp switching off at night, the administrator needs only to turn on the switch for knowing the condition in the room monitored and give urging signal for lamp switch off, while no such signal will be heard in the rooms where lamps had already been turned off.

492. Lighting bulb monitor

Move the photoconductor to the place to be lit by use of two thin wires. With the switch turn on, when the bulb lights normally, the circuit will have no reaction. If the bulb is damaged (this may be simulated by taking down the bulb), an alarm will be given to remind you to repair.

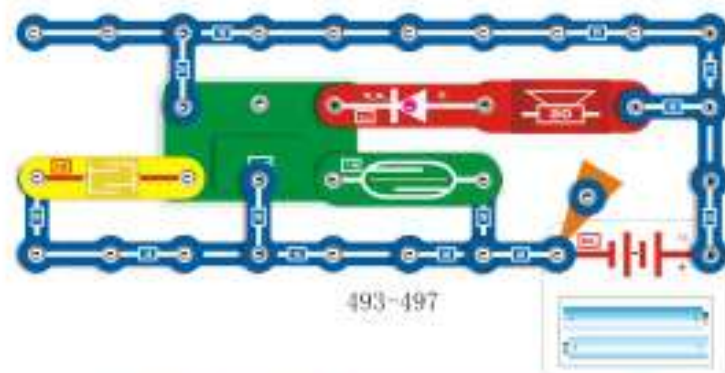

493-497

493. Touch-controlled acousto-optic space war with low pitch sound

Build the circuit and touch the touch plate repeatedly until the loudspeaker plays the space war with low pitch sound and the LED flashes.

494. Magnet-controlled acousto-optic space war with low pitch sound

The loudspeaker can play various of sounds by turn on the reed switch through the magnet repeatedly, and the LED will flash.

495. Light-controlled acousto-optic space war with low pitch sound

Replace the reed switch with a photosensitive resistor and the acousto-optic space war with low pitch sound can be controlled by the light.

496. Hand-controlled acousto-optic space war with low pitch sound

Replace the touch plate with a button switch and the acousto-optic space war with low pitch sound can be controlled by the hand.

497. Water-controlled acousto-optic space war with low pitch sound

Interchange the positions of reed switch and the touch plate, the space war can be controlled by the water.

Question: Is it possible to controlled by the sound if replacing the touch plate with buzzer?

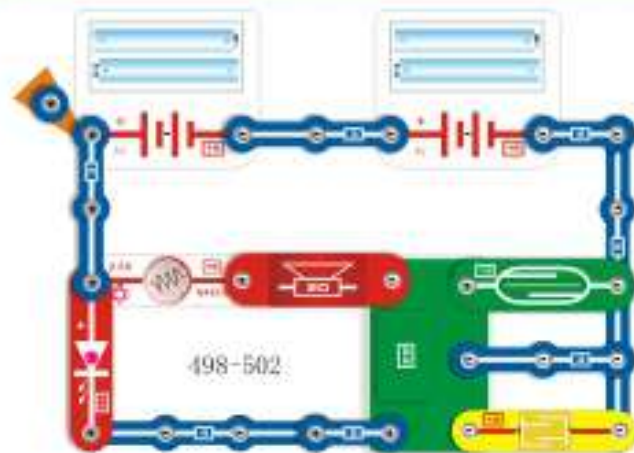

498. Magnet-controlled space war with light and medium pitch sound

Build the circuit and touch the touch plate repeatedly until the loudspeaker plays the space war with medium pitch sound and the lamp lights.

499. Light-controlled space war with light and medium pitch sound

Replace the photosensitive resistor with reed switch, space war with light and medium pitch sound will be controlled with light.

500. Hand-controlled space war with light and medium pitch sound

Replace the switch with reed switch, space war with medium pitch sound will be controlled with hand.

501. Touch-controlled space war with light and medium pitch sound

Replace the switch with touch pad, various medium pitch sound of space war will be heard if repeat touch the touch plate by hand and the lamp lights up.

502. Water-controlled acousto-optic space war with medium pitch sound

Interchange the positions of reed switch and the touch plate; as long as the water drops on the touch plate, the loudspeaker will play all kinds of space war with medium pitch sound, and the lamp will light.

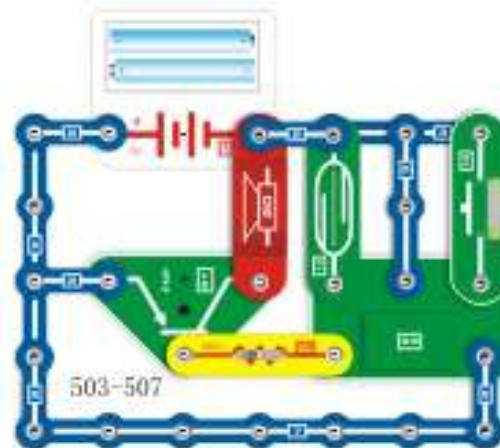

503. Hand-controlled amplified space war

Build the circuit; as long as you press the button switch, the loudspeaker will play the amplified sound of space war.

504. Magnet-controlled amplified space war

The loudspeaker plays the amplified sound of space war by turn on the reed switch through the magnet repeatedly.

505. Light-controlled amplified space war

Replace the reed switch with a photosensitive resistor and the amplified sound of space war can be controlled by the light.

506. Touch-controlled amplified space war

Replace the button switch with a touch plate and touch the touch plate repeatedly until the loudspeaker plays the amplified sound of space war.

507. Water-controlled amplified space war

Replace the button switch with a touch plate; as long as the water drops on the touch plate, the loudspeaker will play the amplified sound of space war.

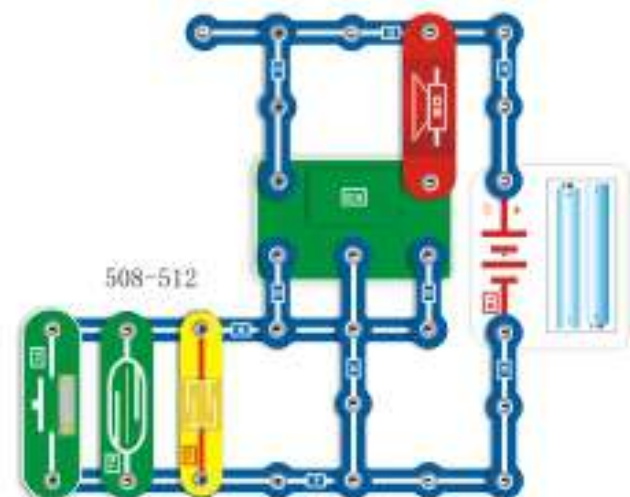

508. Hand-controlled space dogfight

Build the circuit, press the button switch repeatedly by hand, the loudspeaker gives out all kinds of sounds of ferocious space war.

509. Magnet-controlled space dogfight

Turn on the reed switch by magnet repeatedly, the loudspeaker gives out all kinds of sounds of ferocious space war.

510. Touch-controlled space dogfight

Touch the touch plate repeatedly and the loudspeaker gives out all kinds of sounds of ferocious space war.

511. Water-controlled space dogfight

When water drops on the touch plate, the loudspeaker gives out all kinds of sounds of ferocious space war.

512. Light-controlled space dogfight

Replace the touch plate with a photosensitive resistor, the space dogfight can be controlled by the light.

Question: Do you know how to change this circuit of magnet-controlled circuit?

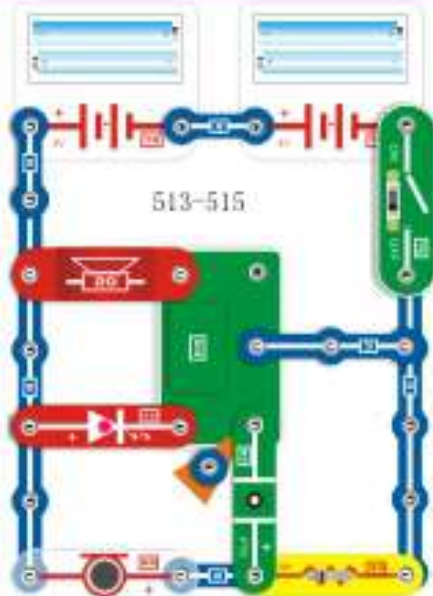

513. Blowing space war in high volume
Turn on the switch, when blowing into the microphone, the loudspeaker plays loud sound of space war.

514. Flashing lamp that may be lighted by air blowing
Replace the loudspeaker with a 6V bulb, it will flicker if blowing into the microphone.

515. LED that may be lighted by air blowing
Replace the loudspeaker with a green LED, it will flicker if blow into the microphone.

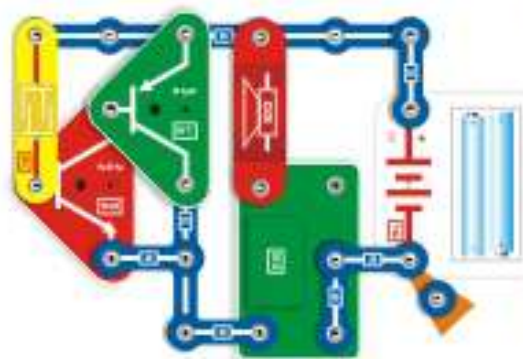

516. Combined-transistors touch-controlled space war
Build the circuit and touch the touch plate, the buzzer will give out the sound of space war; release the hand, the sound stops.

517. Combined-transistors water-controlled space war
When water drops on the touch plate, the buzzer will give out the sound of space war.

518. Combined-transistors magnet-controlled space war
Replace the touch plate with a reed switch, the sound of space war can be controlled by the magnet.

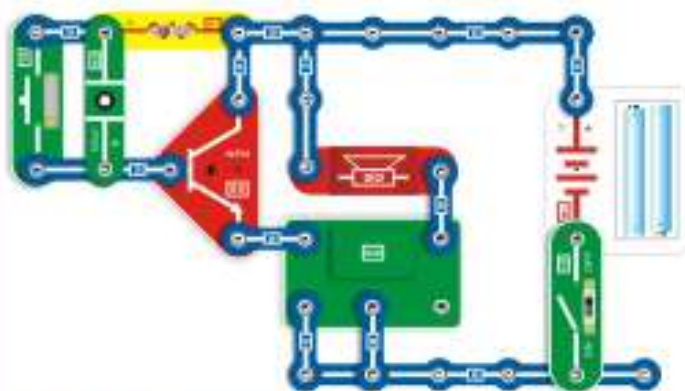

519. Time-delay space war

Turn on the switch, press the button switch, the loudspeaker will give out the sound of space war; release the button switch, the sound will stop after a time delay.

520. Magnet-controlled time-delay space war

Replace the button switch with a reed switch, and the time delay space war can be controlled by the magnet.

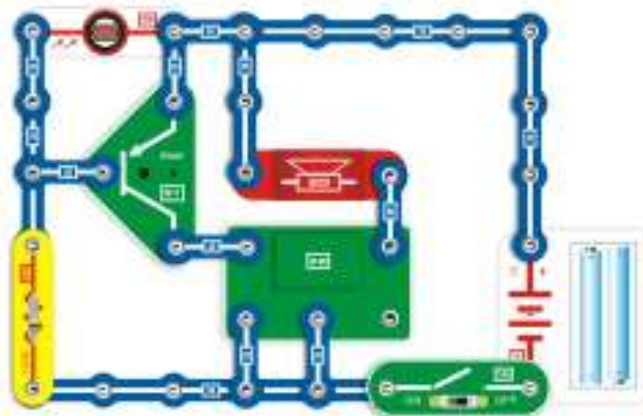

521. Darkness-controlled sound of space war
Turn on the switch. If it is dark or you shield the photosensitive resistor from light by hand, the loudspeaker will give out sound of space war.

522. Dawn light-controlled sound of space war
Interchange the position of the 100K resistor and the photosensitive resistor. Turn on the switch at night. With dawn coming, the loudspeaker will give out sound of space war.



523. Anti-theft sound of tangled space war activated by wire breaking (1)

Build the circuit, and the loudspeaker will give out sound of tangled space war if you connect points A and B together by a wire, the sound will stop. For anti-theft, a long thin wire may be used to thread through bicycle, motorcycle, car, door, window, etc. Then connect the ends of the thin wire to points A and B. If a burglar breaks the wire, the loudspeaker will give out alarming sound of tangled space war immediately.

524. Light-controlled anti-theft sound of tangled space war (1)

Replace the 100K resistor with the photosensitive

resistor. Place it in dark after you turn off the lamp at night. Once a burglar enters the room and strikes light, the loudspeaker will give on alarming sound of tangled space war immediately.

525. Magnet-controlled anti-theft sound of tangled space war(1)

Install a reed switch and a magnet to the doorframe and the door respectively. Make sure that when the door is close, the reed switch is turn on. Then lead the ends of the reed switch out by wires and connect the wires to points A and B of the circuit. If a burglar opens the door, the loudspeaker will give out alarming sound of tangled space war immediately.

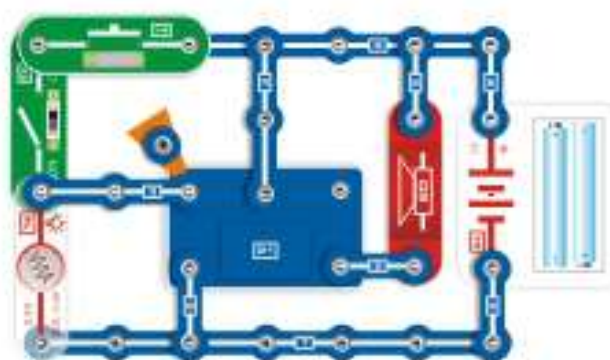

529. Bidirectional doorbell that can transmit information

Build the circuit. Lead the button switch and bulb out by flexible wire and installed them outside the door, and install the switch in the house. When the host is at home, turn on the switch. If a guest presses the button switch, the doorbell will ring to remind the host; meanwhile, the bulb outside the door will light, informing the guest that there is someone at home. When the host is out, turn off the switch. If a guest presses the button switch, the doorbell will not ring, and the bulb will not light, informing the guest that there is no one at home.

530. Magnet-controlled bidirectional music doorbell

Replace the button switch with the reed switch, and the bidirectional music doorbell can be controlled by a magnet.

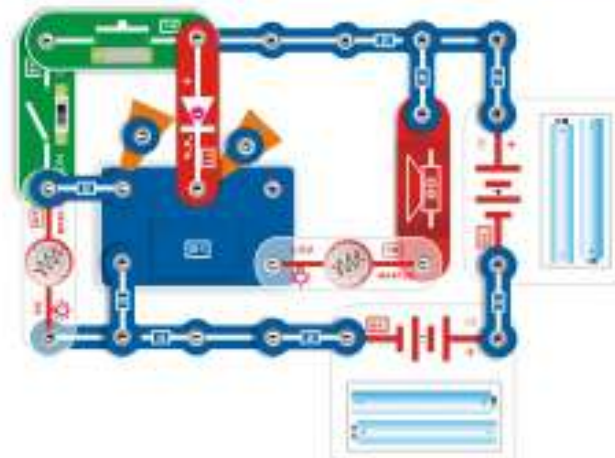

533. Bidirectional medium volume acousto-optic doorbell that can transmit information

The operating principle of this circuit is basically the same as those of the above mentioned bidirectional doorbells, but the volume is a bit higher.

534. Magnet-controlled bidirectional medium volume acousto-optic doorbell

Replace the button switch with the reed switch, and the bidirectional medium volume acousto-optic doorbell can be controlled by a magnet.

535. Bidirectional high volume doorbell that can transmit information

Replace the 2.5V bulb with wire 3, and then it will become bidirectional high volume doorbell.

536. Magnet-controlled bidirectional high volume doorbell

Replace the button switch with the reed switch, and the high volume doorbell can be controlled by a magnet.

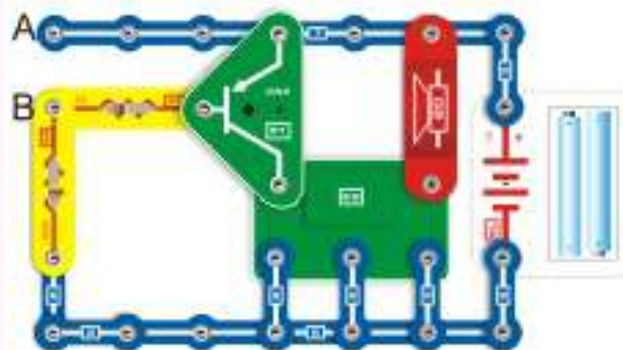

526. Anti-theft sound of tangled space war activated by wire breaking(2)

527. Light-controlled anti-theft sound of tangled space war(2)

528. Magnet-controlled anti-theft sound of tangled space war(2)

The operation and function of 526-528 are the same as those of 523-525. The difference is that these circuits use PNP triode to take control.

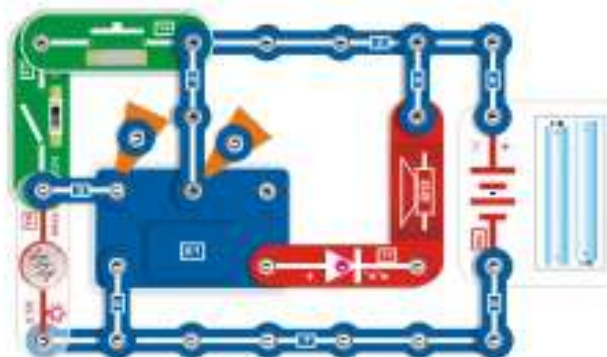

531. Bidirectional low volume doorbell that can transmit information

Compared with the previously mentioned bidirectional doorbell, the volume of this one is lower, applicable for quiet houses.

532. Magnet-controlled bidirectional low volume doorbell

Replace the button switch with the reed switch, and the bidirectional low volume doorbell can be controlled by a magnet.

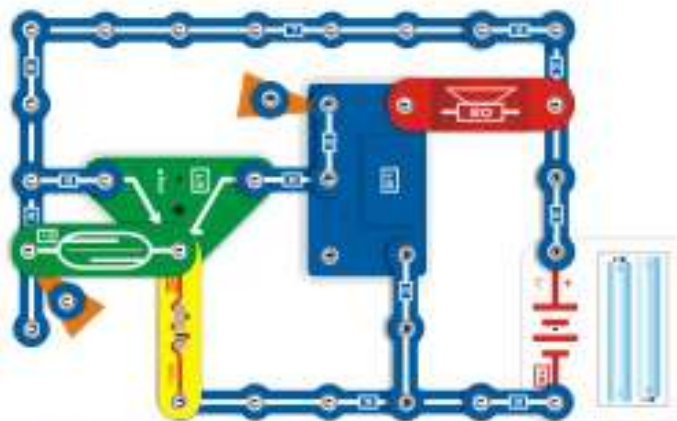

537. Reminder for closing the door of a refrigerator

Install the reed switch of the circuit on one side of the door of the refrigerator, and place the magnet on the other side of the door of the refrigerator. When the door is open, the reed switch is turned on and the loudspeaker makes no sound. When the door is closed, or you forget to close it, the loudspeaker will give out sound of music to remind you to close the door. The music will stop only when the door is closed.

538. Reminding lamp for closing the door of a refrigerator

Replace the loudspeaker with the bulb. When the door of the refrigerator is open, the lamp will light all along to remind you.

Question: Can you build a reminder for closing the door according to the principle of this circuit?

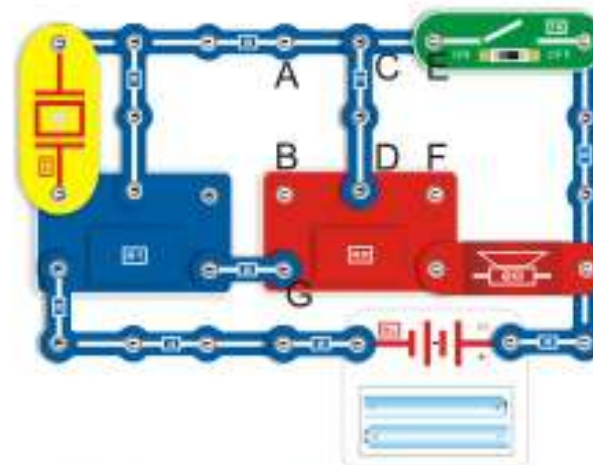

539. Sound-controlled reverberant sound of music police wagon

Build the circuit, turn on the switch, the loudspeaker gives out the reverberant sound of music and police wagon; after sound stops, if clapping or yelling, the reverberant sound will play again and stop after a while.

540. Sound-controlled reverberant sound of music machine gun

Connect C to D and E to F respectively, and the reverberant sound of music machine gun can be controlled by the sound.

541. Sound-controlled reverberant sound of music ambulance

Connect C to D and B to G respectively.

542. Sound-controlled reverberant sound of music fire engine

Connect C to D and A to B respectively.

543. Sound-controlled reverberant sound of music Buddha laugh

Connect C to D and B to F respectively.

544. Motor-controlled reverberant sound of music police wagon

545. Motor-controlled reverberant sound of music machine gun

546. Motor-controlled reverberant sound of music ambulance

547. Motor-controlled reverberant sound of music fire engine

548. Motor-controlled reverberant sound of music Buddha laugh

544-548: Replace the buzzer with a motor, then according to the connection method of 539-543, after music stops, turn the shaft of the motor, the above 5 reverberant sounds can be controlled by the electricity.

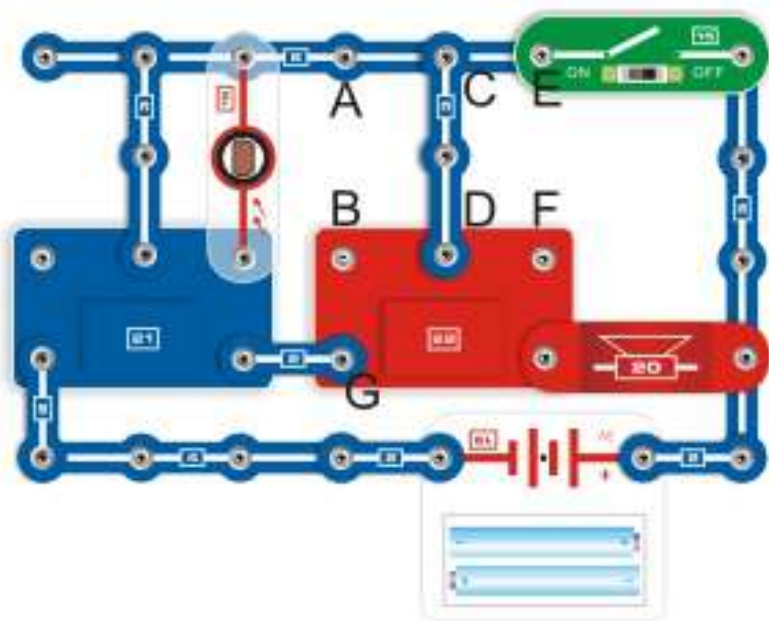

- 549. Light-controlled reverberant sound of music police wagon
- 550. Light-controlled reverberant sound of music machine gun
- 551. Light-controlled reverberant sound of music ambulance
- 552. Light-controlled reverberant sound of music fire engine
- 553. Light-controlled reverberant sound of music Buddha laugh
- 554. Rain-controlled reverberant sound of music police wagon
- 555. Rain-controlled reverberant sound of music machine gun
- 556. Rain-controlled reverberant sound of music ambulance
- 557. Rain-controlled reverberant sound of music fire engine
- 558. Rain-controlled reverberant sound of music Buddha laugh
- 559. Magnet-controlled reverberant sound of music police wagon
- 560. Magnet-controlled reverberant sound of music machine gun
- 561. Magnet-controlled reverberant sound of music ambulance
- 562. Magnet-controlled reverberant sound of music fire engine
- 563. Magnet-controlled reverberant sound of music Buddha laugh

549-553: According to the connection method of 539-543, after music stops, the reverberant sound can be controlled by the light: when there is light, the loudspeaker gives out the music; when there is no light, the music stops.

554-558: Replace the photosensitive resistor with a touch plate, according to the connection method of 539-543, when rain drops on the touch plate, the music will sound.

559-563: replace the photosensitive resistor with a reed switch, according to the connection method of 539-543, the reverberant sound can be controlled by the magnet. Turn on the reed switch by the magnet, the music sounds, remove the magnet, the music stops.

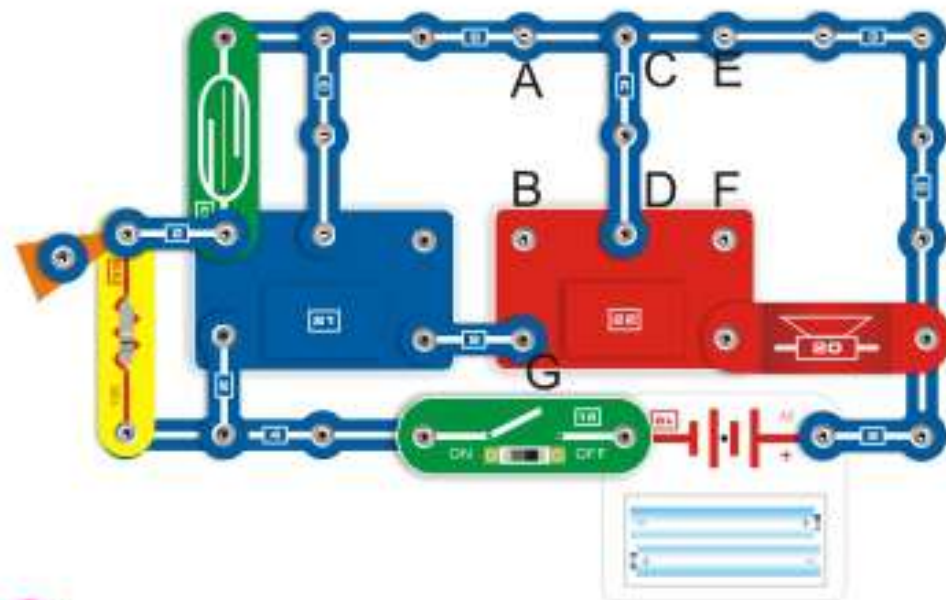

- 564. Magnet-controlled time-delay reverberant sound of music police wagon
- 565. Magnet-controlled time-delay reverberant sound of music machine gun
- 566. Magnet-controlled time-delay reverberant sound of music ambulance
- 567. Magnet-controlled time-delay reverberant sound of music fire engine
- 568. Magnet-controlled time-delay reverberant sound of music Buddha laugh
- 569. Hand-controlled time-delay reverberant sound of music police wagon
- 570. Hand-controlled time-delay reverberant sound of music machine gun
- 571. Hand-controlled time-delay reverberant sound of music fire engine
- 572. Hand-controlled time-delay reverberant sound of music ambulance
- 573. Hand-controlled time-delay reverberant sound of music Buddha laugh

564-568: Turn on the switch, after music stops, according to the connection method of 539-543, the time delay reverberant sound can be controlled by the magnet. Turn on the reed switch through magnet by the magnet, the reverberant music sounds and stays on for a while before stop.

569-573: Replace the reed switch with a button switch, according to the connection method of 539-543, the all kinds of above reverberant sounds can be controlled by the button switch. After music stops, press the button switch, the reverberant music sounds and stays on for a while before stop.

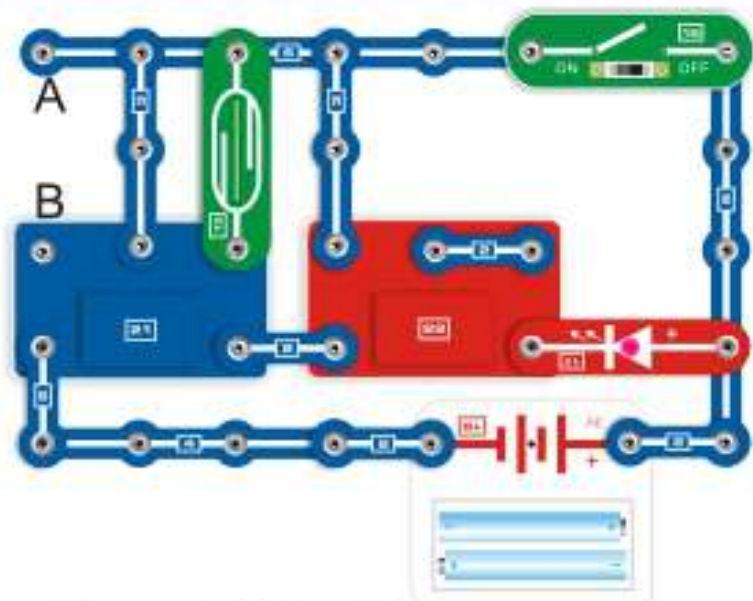

574. Magnet-controlled flashing LED

Turn on the switch, LED lights and goes out repeatedly; after a while, the LED goes out; when place the magnet close to the reed switch, LED flickers again; remove the magnet, the LED goes out.

575. Light-controlled flashing LED

Replace the reed switch with a photosensitive resistor, and the flashing LED can be controlled by the light.

576. Water-controlled flashing LED

Replace the reed switch with a touch plate, and the flashing LED can be controlled by the water.

577. Hand-controlled flashing LED

Replace the reed switch with a button switch, and the flashing LED can be controlled by the hand.

578. Sound-controlled flashing LED

Connect the buzzer to points A and B, wait until the LED go out, it will light again if clapping or whistling, and stays on for a while before go out.

579. Sound-controlled flashing LED with time delay

Connect the buzzer to points A and B, wait until the LED go out, it will light again if clapping or whistling, and stays on for a while before go out.

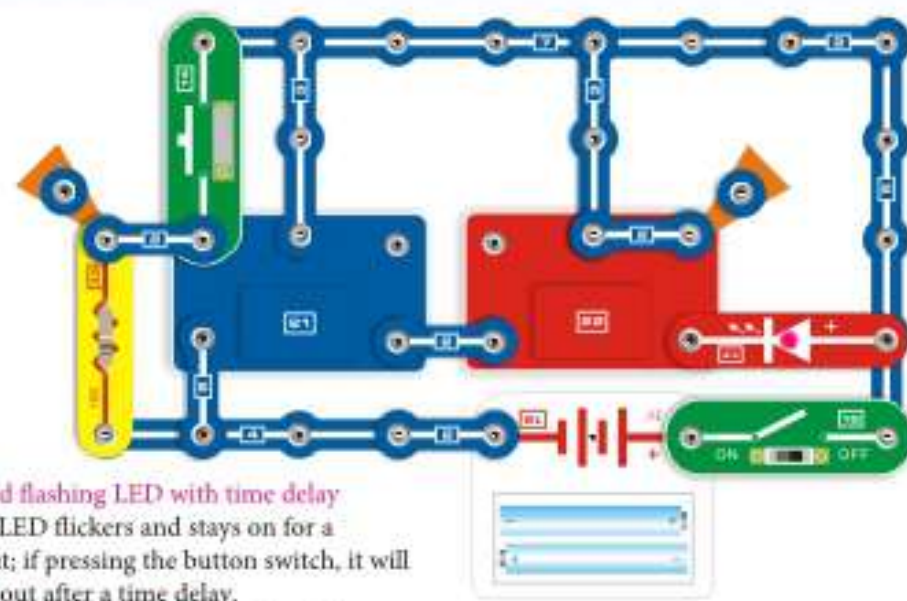

580. Hand-controlled flashing LED with time delay

Turn on the switch, LED flickers and stays on for a while, then it goes out; if pressing the button switch, it will light again and goes out after a time delay.

581. Magnet-controlled flashing LED with time delay

Replace the button switch with a reed switch, after LED goes out, turn on the reed switch by the magnet, the LED will light again and goes out after a time delay.

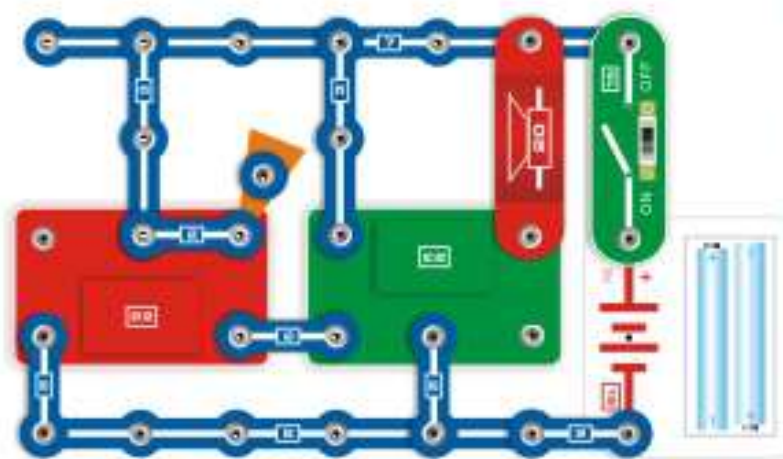

582. Automatic tangled space war

Turn on the switch, the loudspeaker will automatically give out all kinds of sounds of space war, just like a ferocious tangled space war.

583. Space flashing lamp

Replace the loudspeaker with a 2.5V bulb, turn on the switch, the bulb will automatically flash.

584. Magnet-controlled space flashing lamp

Replace the switch with a reed switch, and the space flashing lamp can be controlled by the magnet.

585. Magnet-controlled space dogfight

Install the loudspeaker in the original place, replace the switch with a reed switch, and the tangled space war can be controlled by the magnet.

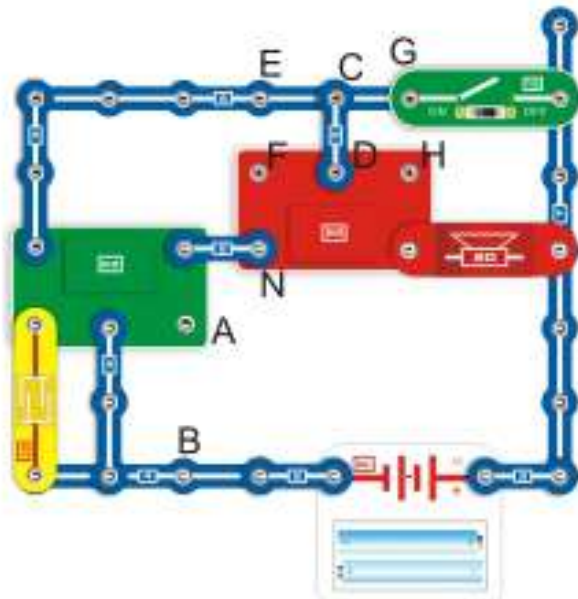

586. Touch-controlled reverberant utensil of space police wagon

Turn on the switch, and touch the touch plate repeatedly, the loudspeaker will give out all kinds of reverberant sounds of space war and police wagon.

587. Touch-controlled reverberant utensil of space machine gun

Connect C to D and G to H respectively, and touch the touch plate repeatedly, the loudspeaker will give out all kinds of reverberant sounds of space war and machine gun.

588. Touch-controlled reverberant utensil of space fire engine

Connect C to D and F to E respectively, and operate according to the above methods.

589. Touch-controlled reverberant utensil of space ambulance

Connect C to D and F to N respectively, and operate according to the above methods.

590. Touch-controlled reverberant utensil of space Buddha laugh

Connect C to D and F to H respectively, and operate according to the above methods.

591. Rain-controlled reverberant utensil of space police wagon

592. Rain-controlled reverberant utensil of space machine gun

593. Rain-controlled reverberant utensil of space fire engine

594. Rain-controlled reverberant utensil of space ambulance

595. Rain-controlled reverberant utensil of space Buddha laugh

591-595: Connect the touch plate to points A and B, then according to the connection method of 586-590, when rain drops on the touch plate, above 5 reverberant sounds can be heard.

596. Hand-controlled reverberant utensil of space police wagon

597. Hand-controlled reverberant utensil of space machine gun

598. Hand-controlled reverberant utensil of space fire engine

599. Hand-controlled reverberant utensil of space ambulance

600. Hand-controlled reverberant utensil of space Buddha laugh

596-600: Connect the button switch to points A and B, then according to the connection method of 586-590, if pressing the button switch repeatedly, the above 5 reverberant sounds can be heard.

601. Magnet-controlled reverberant utensil of space police wagon

602. Magnet-controlled reverberant utensil of space machine gun

603. Magnet-controlled reverberant utensil of space fire engine

604. Light-controlled reverberant utensil of space ambulance

605. Light-controlled reverberant utensil of space Buddha laugh

601-605: Connect the reed switch to points A and B, then according to the connection method of 586-590, if turn on the reed switch by the magnet repeatedly, the above 5 reverberant sounds can be heard.

606. Light-controlled reverberant utensil of space police wagon

607. Light-controlled reverberant utensil of space machine gun

608. Light-controlled reverberant utensil of space fire engine

609. Light-controlled reverberant utensil of space ambulance

610. Light-controlled space Sound of Buddha laugh reverberant utensil

606-610: Connect the photosensitive resistor with points A and B, then according to the connection method of 586-590, if shading the light by hand repeatedly, the above 5 reverberant sounds can be heard.

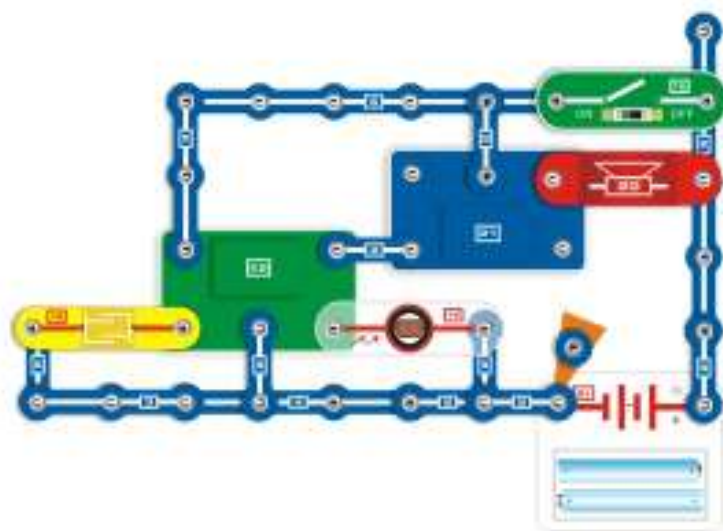

611. Light-controlled reverberant utensil of space music

Turn on the switch, when there is light on the photosensitive resistor, the reverberant sound of space music can be heard; shield the light, the reverberant sound stops.

612. Touch-controlled reverberant utensil of space music

Remove the photosensitive resistor and touch the touch plate by hand repeatedly, the reverberant sound of space war and music can be heard.

613. Water-controlled reverberant utensil of space music

Replace the photosensitive resistor with the touch plate, when water drops on the touch plate, the reverberant sound of space war and music can be heard.

614. Hand-controlled reverberant utensil of space music

Replace the photosensitive resistor by the button switch, when pressing the button switch repeatedly, the reverberant sound of space war and music can be heard.

615. Magnet-controlled reverberant utensil of space music

Replace the photosensitive resistor with the reed switch, when turn on the reed switch by the magnet, the reverberant sound of space war and music can be heard.

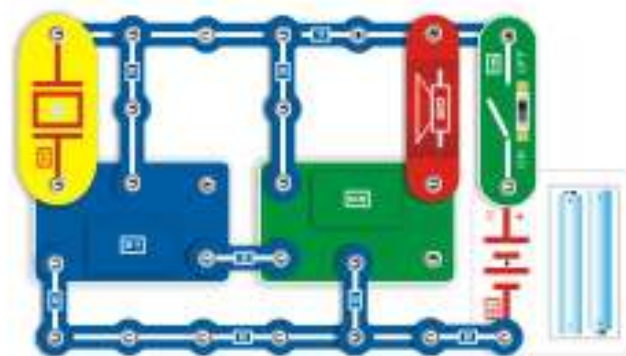

616. Sound-controlled time-delay space war

Turn on the switch, the loudspeaker will give out the sound of space war; after the sound stops, if clapping or yelling, the sound of space war will sound again and stays on for a while, then stop

617. Motor-controlled time-delay space war

Replace the buzzer with a motor; wait until the sound stops, if turning the shaft of the motor, the sound of space war will sound again and stays on for a while before stop.

618. Sound-controlled time-delay space flashing lamp

Resume the buzzer, replace the loudspeaker with a 2.5V bulb, if clapping or yelling, the bulb will light and flash again, and go out after a while.

619. Sound-controlled time-delay space flashing LED

Resume the buzzer, replace the loudspeaker with a LED, if clapping or yelling, the LED will light and flash again, and go out after a while.

620. Motor-controlled time-delay space flashing lamp

Replace the buzzer with a motor and replace the loudspeaker with a 2.5V bulb; if turning the shaft of the motor, the bulb will light again and go out after a while.

621. Motor-controlled time-delay space flashing LED

Replace the buzzer with a motor and replace the loudspeaker with a LED; if turning the shaft of the motor, the bulb will light again and goes out after a while.

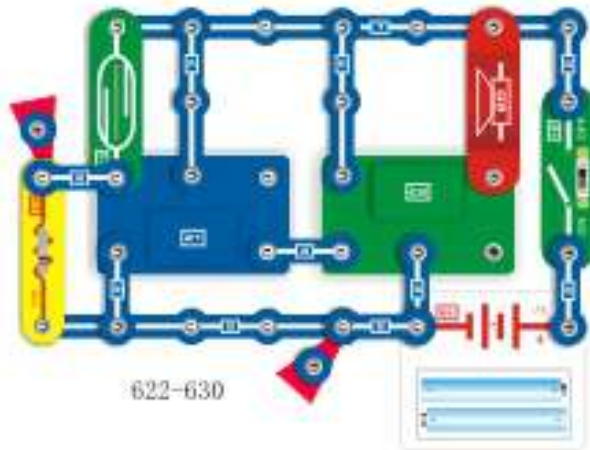

622. Magnet-controlled time-delay space war

Turn on the switch, the loudspeaker will give out the sound of the space war; after sound stops, turn on the reed switch by the magnet, the sound of space war will sound again, and stop after a while.

623. Magnet-controlled time-delay space flashing lamp

Replace the loudspeaker with a 2.5V bulb, turn on the reed switch by the magnet, the bulb will light again and goes out after a while.

624. Magnet-controlled time-delay space flashing LED

Replace the loudspeaker with a LED, turn on the reed switch by the magnet, the LED will light again and goes out after a while.

625. Hand-controlled time-delay space war

626. Hand-controlled time-delay space flashing lamp

627. Hand-controlled time-delay space flashing LED

625-627: Replace the reed switch with a button switch, can control the above circuit by hand, the effects of it can be achieved.

628. High-sensitivity sound-controlled time-delay space war

629. High-sensitivity sound-controlled time-delay space flashing lamp

630. High-sensitivity sound-controlled space flashing LED

628-630: Replace the reed switch with a photosensor(anode is upward), when clapping or whistling a few feet away, the above circuit effects can be achieved.

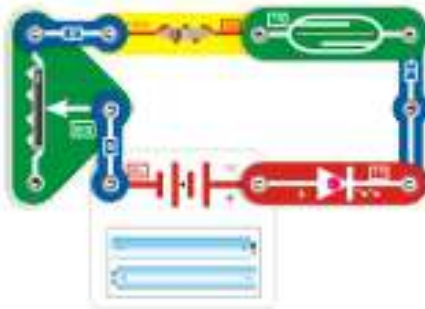

631. Magnet-controlled changeable LED

Build the circuit, turn on the reed switch by the magnet, then adjust the variable resistor, the brightness of the LED will change accordingly; remove the magnet, LED goes out.

632. Button switch-controlled variable LED

Replace the reed switch with a button switch, adjust the variable resistor to different positions, and the brightness of LED can be controlled by the button switch.

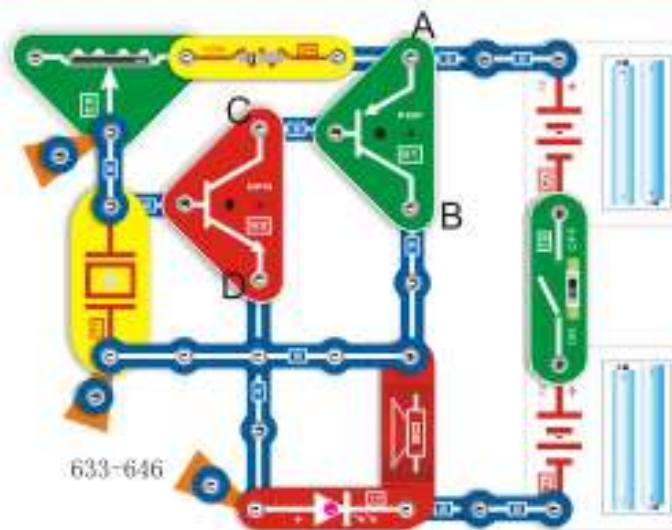

633. Multi-tone generator

Turn on the switch, adjust the variable resistor, the loudspeaker will give out all kinds of tones.

634. Light-controlled electronic piano

Replace the 100K resistor with photosensitive resistor. Adjust the varistor to suitable position. Snap your fingers over the photosensitive resistor or shade it with your fingers, the loudspeaker will give out different tones.

635. Ticks of touching

Replace the 100K resistor with touch plate. If you touch the touch plate, the loudspeaker will tick.

636. Electronic cicada

Reinstall the 100K resistor. Parallely connect a 0.02 μ F capacitor above the buzzer reed. The buzzer will give out the sound of cicada.

637. Light-controlled electronic cicada

Just replace the 100K resistor with photosensitive resistor, then you have a light-controlled electronic cicada.

638. Sound of motor ship

Parallely connect a 0.1 μ F capacitor to the buzzer reed, the loudspeaker will give out sound of motor ship.

639. Light-controlled sound of motor ship

Just replace the 100K resistor with photosensitive resistor, then you have a light-controlled sound of

motor ship.

640. Adjustable electronic metronome

Connect a 10 μ F capacitor in parallel with the buzzer (anode is upward), the loudspeaker will give out a sound of beat. The speed of beat is adjustable.

641. Adjustable electronic flashing lamp

Remain the 10 μ F capacitor, change the loudspeaker with a 6V bulb, which will flicker and the flicker speed can be adjusted.

642. Sound of steamship

Replace the 100K resistor with a photoconductor, the sound of motor ship may be controlled optically.

643. Sound of mosquito

Connect the 10 μ F capacitor to C and D (anode is upward). The loudspeaker will give out sound of mosquito.

644. Flash sound and light lamp

Connect the 10 μ F capacitor in parallel with the top of the buzzer (anode is upward), the 470 μ F capacitor in parallel with 100K resistor to regulate the variable resistor to a certain position. The LED fast flash and the loudspeaker will give out sounds.

645. Sound of Suona

Replace the 100K resistor with the 10K resistor, adjustable variable resistor, the loudspeaker will give out sound of suona.

646. Water-controlled electronic metronome

Replace the 100K resistor with the touch pad, as long as there are water drops in the touch pad, the loudspeaker will give out playing sound of metronome.

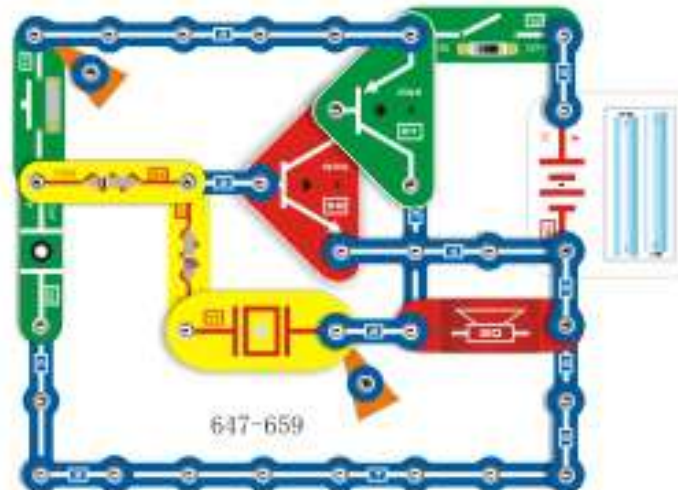

647. Time-delay high-pitch doorbell

Turn on the switch. Press the button switch once then release, high-pitch sound given by the loud speaker will last for some time.

648. Time-delay metronome

Connect a 10 μ F capacitor in parallel with the buzzer and above it. Press the button switch, the loudspeaker will give out time beating sound that lasts for some time.

649. Time-delay flash light

Leave the 10 μ F capacitor as it is. Replace the loudspeaker with a 2.5V bulb. When the button switch is pressed, the flash light will work for some time.

650. Sound of airplane

Connect the buzzer in parallel with the 0.1 μ F capacitor, replace the 100 μ F capacitor with the 470 μ F, press the button switch, the loudspeaker will give out the sound of airplane.

651. Sound of motorcycle

Connect the buzzer in parallel with the 0.1 μ F capacitor, press the button switch, the loudspeaker will give out the sound of motorcycle.

652. Sound of telegraph transmitter

Connect the buzzer in parallel with the 0.1 μ F capacitor, disconnect 100 μ F capacitor, fast pressing the button switch, it give out sound of telegraph transmitter.

653. Creaking of the wooden door

Connect the buzzer in parallel with the 0.1UF capacitor, replace the 100UF capacitor with the 10UF, press the button switch, the loudspeaker will give out the creaking of the wooden door.

654. Magnet-controlled time-delay doorbell with high pitch sound

655. Magnet-controlled time-delay metronome

656. Magnet-controlled sound of airplane

657. Magnet-controlled sound of motorcycle

658. Magnet-controlled sound of telegraph transmitter

659. Magnet-controlled sound of creaking of the wooden door

654-659. Replace the button switch with reed switch, then place the magnet close to the reed switch, it can get a sound effects in the circuit corresponding to the above 647-653.



660. Magnet-controlled anti-theft alarm with high pitch sound

Install the reed switch and the magnet on the door leaf and doorframe respectively, and they shall be connected with points A and B by thin wire; when door is close, the reed switch is turn on; as long as thief open the door, the loudspeaker will give out high pitch sound of alarming.

661. High pitch sound generator

When the switch is turn on, and the loudspeaker gives out high pitch sound.

662. Medium pitch sound generator

Parallely connect a 0.02UF capacitor to the buzzer. The loudspeaker will give the medium pitch sound.

663. Low pitch sound generator

Parallely connect the 0.1UF capacitor to the buzzer. The loudspeaker will give out low pitch sound.

664. Simple electronic metronome

Parallely connect a 10UF capacitor to the buzzer(the anode is in left). The loudspeaker will give out sound of rhythm beater.

665. Simple flashing light

Leave the parallel connection between the 10UF capacitor and the buzzer as it is, Replace the loudspeaker with a 2.5V bulb, which will flash.

666. Low sound of mosquito

Leave the bulb as it be. Remove the 10UF capacitor. The buzzer will give out low sound of mosquito.

667. Anti-theft alarm with high pitch sound

Install the loudspeaker to original place, and connect AB by thin wire; as long as the thief breaks the wire, the loudspeaker will give out high pitch sound of alarming.

668. Anti-theft alarm with medium pitch sound

Based on the 635 circuit, add a 0.02UF capacitor to parallely connect it to the buzzer.

669. Magnet-controlled anti-theft alarm with medium pitch sound

Based on the 636 circuit, add a 0.02UF capacitor to parallely connect it to the buzzer.

670. Anti-theft alarm with low pitch sound

Based on the 635 circuit, add a 0.01UF capacitor to parallely connect it to the buzzer.

671. Magnet-controlled anti-theft alarm with low pitch sound

Based on the 636 circuit, just need add a 0.1UF capacitor to parallely connect it to the buzzer.

672. Flashing anti-theft alarm lamp

Parallely connect a 10UF capacitor to the buzzer (the anode is in left), then replace the loudspeaker with a 2.5V bulb, connect AB by thin wire; as long as the thief breaks the wire, the bulb will flicker for alarming.

673. Magnet-controlled flashing anti-theft alarm lamp

According to the principle above, connect the both ends of the reed switch to points A and B.

Question: What's the reaction of parallely connect a capacitor to the 100k resistor?

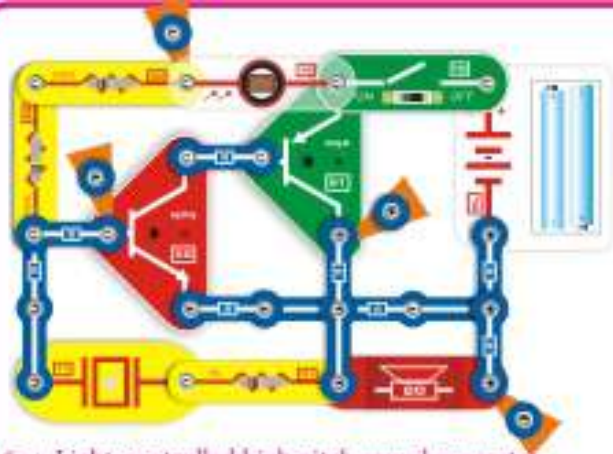

674. Light-controlled high pitch sound generator

Turn on the switch. If you shield the photosensitive resistor from light back and forth by hand, the loudspeaker will give out the high pitch sound of varying tone.

675. Touch-controlled high pitch sound generator

Replace the photosensitive resistor with a touch plate, and the loudspeaker will give out high pitch sound if touching the touch plate.

676. Light-controlled medium pitch sound generator

Based on the 643 circuit, add a 0.02UF capacitor to parallelly connect it to the buzzer.

677. Touch-controlled medium pitch sound generator

Keep the 0.02UF capacitor, and replace the photosensitive resistor with a touch plate.

678. Light-controlled low pitch sound generator

Based on the 643 circuit, add a 0.1UF capacitor to parallelly connect it to the buzzer.

679. Touch low pitch sound generator

Keep the 0.1UF capacitor, and replace the photosensitive resistor with a touch plate.

680. Light-controlled flashing alarm lamp

Resume the original circuit, use a 10UF capacitor to parallelly connect it to the buzzer (the anode is in left), then replace the loudspeaker with a 2.5V bulb, when there is light, the bulb lights.

681. Magnet-controlled high pitch sound generator

Based on the 643 circuit, replace the photosensitive resistor with a reed switch.

682. Magnet-controlled medium pitch sound generator

Based on the 645 circuit, replace the photosensitive resistor with a reed switch.

683. Magnet-controlled low pitch sound generator

Based on the 647 circuit, replace the photosensitive resistor with a reed switch.

684. Magnet-controlled flashing lamp

Based on the 649 circuit, replace the photosensitive resistor with a reed switch.

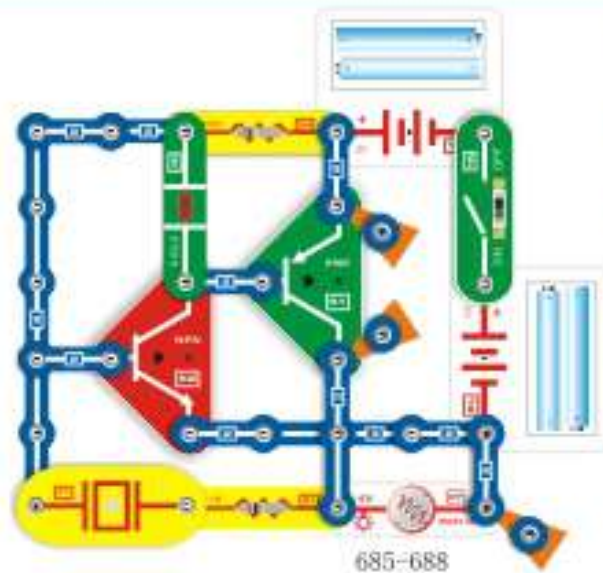

685. Sound of big mosquito

Install the circuit, the buzzer will give out the sound of big mosquito.

686. Flashing lamp

Connect a 10μf capacitor in parallel with the buzzer (anode is left), the lamp flashes.

687. Electronic metronome

Reserve the 10μf capacitor, replace the bulb with the loudspeaker, the loudspeaker will give off a sound of time beating.

688. High-pitch oscillator

Reserve the loudspeaker, remove the 100μf capacitor, the loudspeaker will give out sound of high-pitch.

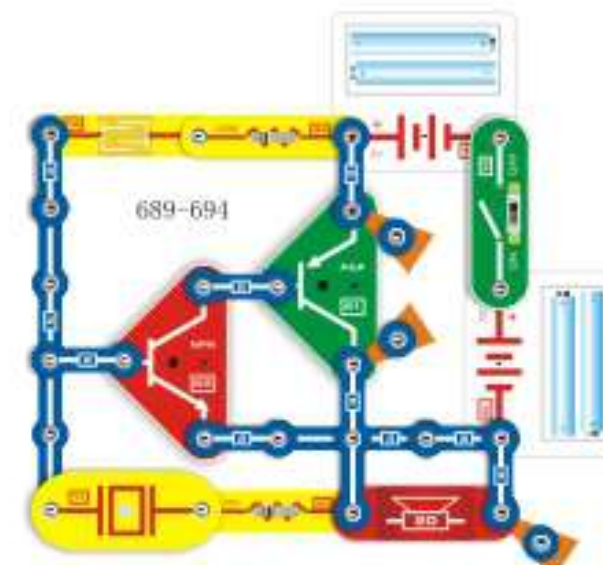

689. Touch-controlled high-pitch oscillator

Touch the touch plate, the loudspeaker will give out sound of high-pitch oscillation.

690. Light-controlled high-pitch oscillator

Replace the touch plate with the photosensitive resistor, the sound of oscillation can be controlled by light.

691. Light-controlled sound of mosquito

Replace the loudspeaker with the 6V bulb, the sound of mosquito can be controlled by light.

692. Touch-controlled sound of mosquito

Reserve the 6V bulb, replace the photosensitive resistor with the touch plate, touch it by hand, the buzzer will give out sound of mosquito.

693. Magnet-controlled sound of mosquito

Reserve the 6V bulb, replace the touch plate with reed switch.

694. Magnet-controlled high-pitch oscillator

Only in the 659 circuit, replace the touch plate with the reed switch.



695. Variable high-pitch generator

Adjust the variable resistor, the loudspeaker will give out variable high-pitch.

696. Light-controlled variable high-pitch

Replace the 100K resistor with photosensitive resistor, adjust the variable resistor, and if shading the light by hand, the loudspeaker will give out the variable high-pitch which can be controlled by light.

697. Touch-controlled variable high-pitch

Replace the 100K resistor with touch plate, at the same time, touch it by hand, adjust the variable resistor, the loudspeaker will give out the variable high-pitch.

698. Magnet-controlled variable high-pitch

Replace the 100K resistor with the reed switch, at the same time, turn on the reed switch by magnet, adjust the variable resistor, the loudspeaker will give out the variable high-pitch.

Question: Interchange the position of 51# and 52# in those two circuits, what's the effects?