

MM54HC148/MM74HC148 8-3 Line Priority Encoder

General Description

This priority encoder utilizes advanced silicon-gate CMOS technology. It has the high noise immunity and low power consumption typical of CMOS circuits, as well as the speeds and output drive similar to LB-TTL.

This priority encoder accepts 8 input request lines 0–7 and outputs 3 lines A0–A2. The priority encoding ensures that only the highest order data line is encoded. Cascading circuitry (enable input EI and enable output EO) has been provided to allow octal expansion without the need for external circuitry. All data inputs and outputs are active at the low logic level.

All inputs are protected from damage due to static discharge by internal diode clamps to V_{CC} and ground.

Features

- Typical propagation delay: 13 ns
- Wide supply voltage range: 2V–6V

Connection Diagram

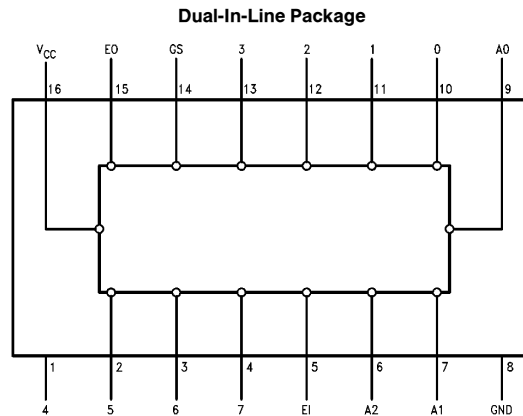

Order Number MM54HC148 or MM74HC148

TL/F/9390-1

Truth Table

		Inputs								Outputs				
	EI	0	1	2	3	4	5	6	7	A2	A1	A0	GS	EO
H	X	X	X	X	X	X	X	X	X	H	H	H	H	H
L	H	H	H	H	H	H	H	H	H	H	H	H	H	L
L	X	X	X	X	X	X	X	X	L	L	L	L	L	H
L	X	X	X	X	X	X	L	H	H	L	L	L	L	H
L	X	X	X	X	L	H	H	H	H	L	H	H	L	H
L	X	X	X	L	H	H	H	H	H	H	L	L	L	H
L	X	X	L	H	H	H	H	H	H	H	L	H	L	H
L	X	L	H	H	H	H	H	H	H	H	H	L	L	H
L	L	H	H	H	H	H	H	H	H	H	H	H	L	H

H = High, L = Low, X = irrelevant

Absolute Maximum Ratings (Notes 1 & 2)

If Military/Aerospace specified devices are required, please contact the National Semiconductor Sales Office/Distributors for availability and specifications.

Supply Voltage (V_{CC})	-0.5 to +7.0V
DC Input Voltage (V_{IN})	-1.5 to V_{CC} + 1.5V
DC Output Voltage (V_{OUT})	-0.5 to V_{CC} + 0.5V
Clamp Diode Current (I_{IK}, I_{OK})	±20 mA
DC Output Current, per pin (I_{OUT})	±25 mA
DC V_{CC} or GND Current, per pin (I_{CC})	±50 mA
Storage Temperature Range (T_{STG})	-65°C to +150°C
Power Dissipation (P_D) (Note 3)	600 mW
S.O. Package only	500 mW
Lead Temperature (T_L) (Soldering 10 sec.)	260°C

Operation Conditions

	Min	Max	Units
Supply Voltage (V_{CC})	2	6	V
DC Input or Output Voltage (V_{IN}, V_{OUT})	0	V_{CC}	V
Operating Temperature Range (T_A)			
MM74HC	-40	+85	°C
MM54HC	-55	+125	°C
Input Rise or Fall Times (t_r, t_f)			
$V_{CC} = 2.0V$		1000	ns
$V_{CC} = 4.5V$		500	ns
$V_{CC} = 6.0V$		400	ns

DC Electrical Characteristics (Note 4)

Symbol	Parameter	Conditions	V_{CC}	$T_A = 25^\circ C$		74HC	54HC	Units					
						$T_A = -40 \text{ to } 85^\circ C$	$T_A = -55 \text{ to } 125^\circ C$						
				Typ	Guaranteed Limits								
V_{IH}	Minimum High Level Input Voltage		2.0V		1.5	1.5	1.5	V					
			4.5V		3.15	3.15	3.15	V					
			6.0V		4.2	4.2	4.2	V					
V_{IL}	Maximum Low Level Input Voltage**		2.0V		0.5	0.5	0.5	V					
			4.5V		1.35	1.35	1.35	V					
			6.0V		1.8	1.8	1.8	V					
V_{OH}	Minimum High Level Output Voltage	$V_{IN} = V_{IH}$ or V_{IL} $ I_{OUT} \leq 20 \mu A$	2.0V	2.0	1.9	1.9	1.9	V					
			4.5V	4.5	4.4	4.4	4.4	V					
			6.0V	6.0	5.9	5.9	5.9	V					
		4.5V	4.7	3.96	3.84	3.7	V						
								6.0V	5.2	5.48	5.34	5.2	V
V_{OL}	Maximum Low Level Output Voltage	$V_{IN} = V_{IH}$ or V_{IL} $ I_{OUT} \leq 20 \mu A$	2.0V	0	0.1	0.1	0.1	V					
			4.5V	0	0.1	0.1	0.1	V					
			6.0V	0	0.1	0.1	0.1	V					
		4.5V	0.2	0.26	0.33	0.4	V						
								6.0V	0.2	0.26	0.33	0.4	V
I_{IN}	Maximum Input Current	$V_{IN} = V_{CC}$ or GND	6.0V		±0.1	±1.0	±1.0	μA					
I_{CC}	Maximum Quiescent Supply Current	$V_{IN} = V_{CC}$ or GND $I_{OUT} = 0 \mu A$	6.0V		8.0	80	160	μA					

Note 1: Absolute Maximum Ratings are those values beyond which damage to the device may occur.

Note 2: Unless otherwise specified all voltages are referenced to ground.

Note 3: Power Dissipation temperature derating—plastic "N" package: -12 mW/°C from 65°C to 85°C, ceramic "J" package: -12 mW/°C from 100°C to 125°C.

Note 4: For a power supply of 5V ± 10% the worst case output voltages (V_{OH} , and V_{OL}) occur for HC at 4.5V. Thus the 4.5V values should be used when designing with this supply. Worst case V_{IH} and V_{IL} occur at $V_{CC} = 5.5V$ and 4.5V respectively. (The V_{IH} value at 5.5V is 3.85V.) The worst case leakage current (I_{IN} , I_{CC} , and I_{OZ}) occur for CMOS at the higher voltage and so the 6.0V values should be used.

** V_{IL} limits are currently tested at 20% of V_{CC} . The above V_{IL} specification (30% of V_{CC}) will be implemented no later than Q1, CY'89.

AC Electrical Characteristics $V_{CC} = 5V, T_A = 25^\circ C, C_L = 15 \text{ pF}, t_r = t_f = 6 \text{ ns}$

Symbol	Parameter	Conditions	Typ	Units
t_{PHL}, t_{PLH}	Maximum Propagation Delay, Any Input to Any Output		14	ns

AC Electrical Characteristics $V_{CC} = 2.0V \text{ to } 6.0V, C_L = 50 \text{ pF}, t_r = t_f = 6 \text{ ns}$ (unless otherwise specified)

Symbol	Parameter	V_{CC}	$T_A = 25^\circ C$		74HC	54HC	Units
			Typ	Guaranteed Limits		-40°C to +85°C	
t_{PHL}, t_{PLH}	Inputs 0-7 to Outputs A0, A1, A2	2.0V		140	175	210	ns
		4.5V	14	28	35	42	ns
		6.0V		24	30	36	ns
t_{PHL}, t_{PLH}	Inputs 0-7 to Output EO	2.0V		140	175	210	ns
		4.5V	15	28	35	42	ns
		6.0V		24	30	36	ns
t_{PHL}, t_{PLH}	Inputs 0-7 to Output GS	2.0V		160	200	240	ns
		4.5V	17	32	40	48	ns
		6.0V		27	34	41	ns
t_{PHL}, t_{PLH}	Input EI to Outputs A0, A1, A2	2.0V		160	200	240	ns
		4.5V	17	32	40	48	ns
		6.0V		27	34	41	ns
t_{PHL}, t_{PLH}	Input EI to Output GS	2.0V		100	125	150	ns
		4.5V	12	20	25	30	ns
		6.0V		17	21	26	ns
t_{PHL}, t_{PLH}	Input EI to Output EO	2.0V		100	125	150	ns
		4.5V	12	20	25	30	ns
		6.0V		17	21	26	ns
t_r, t_f	Maximum Output Rise and Fall Time	2.0V		75	95	110	ns
		4.5V	7	15	19	22	ns
		6.0V		13	16	19	ns
C_{pd}	Power Dissipation Capacitance (Note 5)		52				pF
C_{in}	Maximum Input Capacitance		5	10	10	10	pF

Note 5: C_{pd} determines the no load dynamic power consumption, and the no load dynamic current consumption.

HC148 Schematic for Datasheet

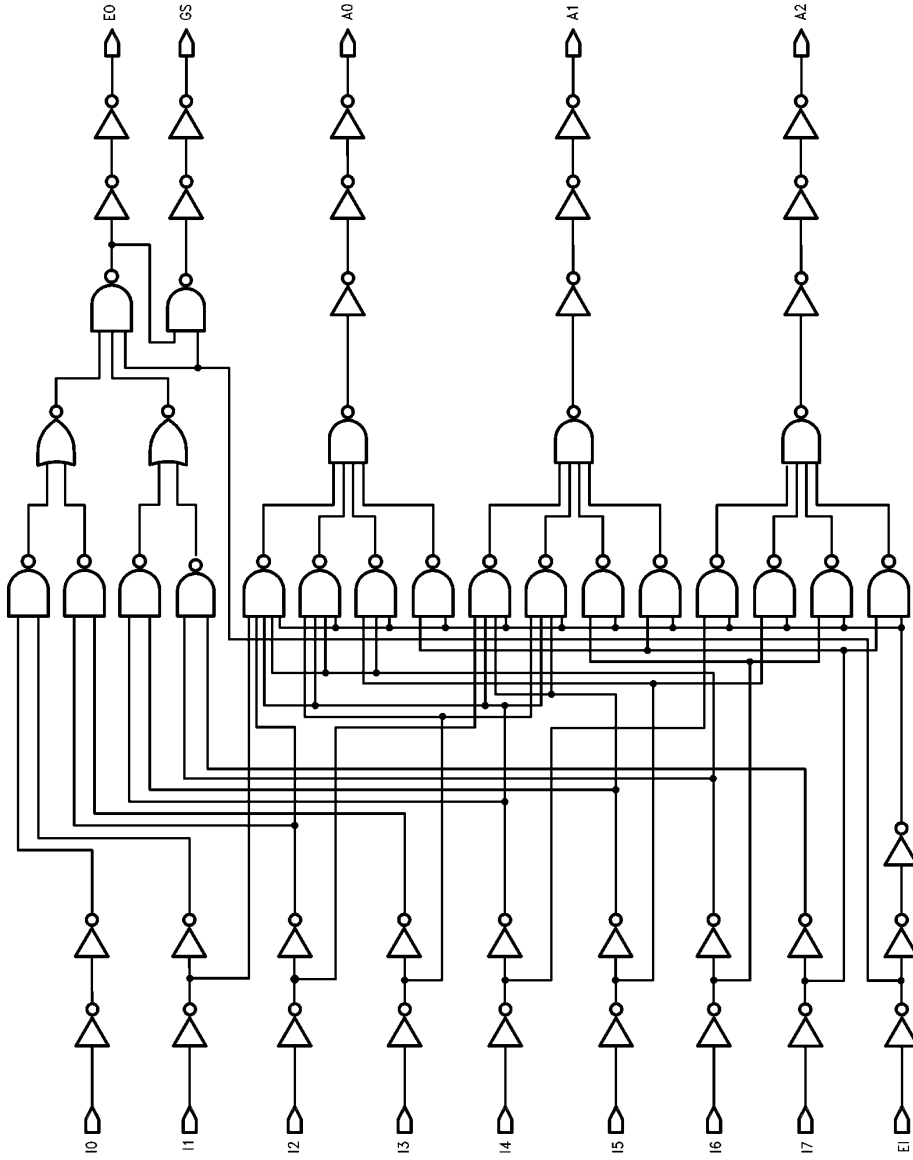

TL/F/9890-3

Logic Diagram

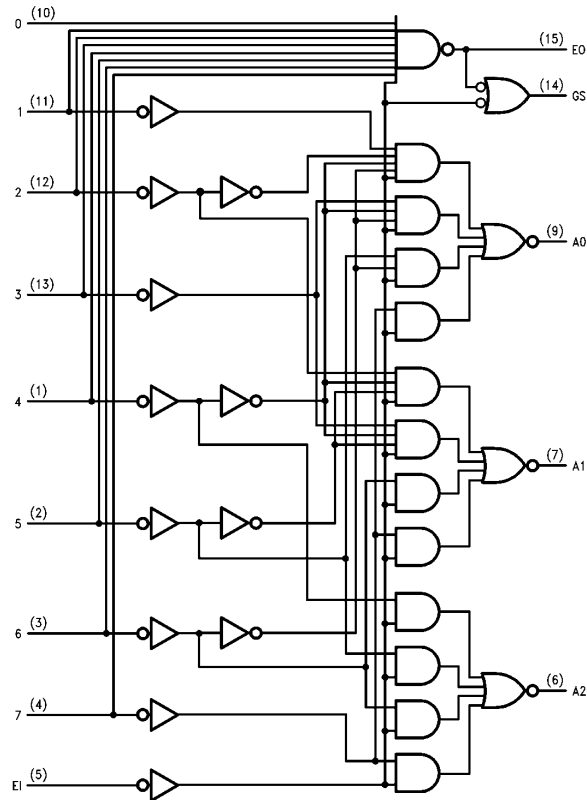

TL/F/9390-2

Physical Dimensions inches (millimeters)

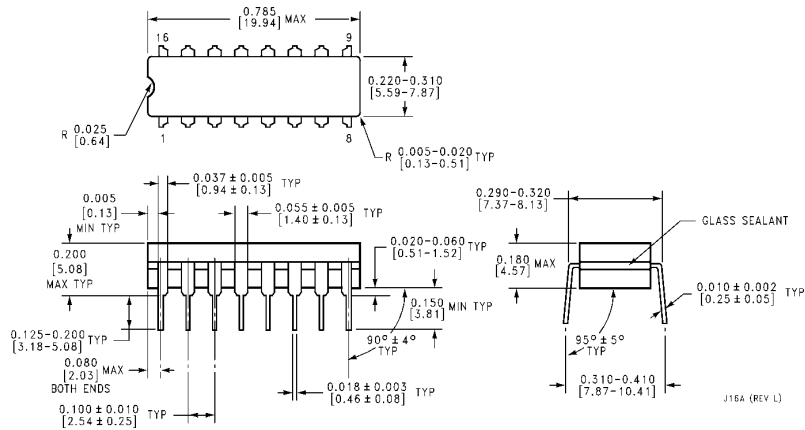

Ceramic Dual-In-Line Package (J)
Order Number MM54HC148 or MM74HC148
NS Package Number J16A

J16A (REV L)

Physical Dimensions inches (millimeters) (Continued)

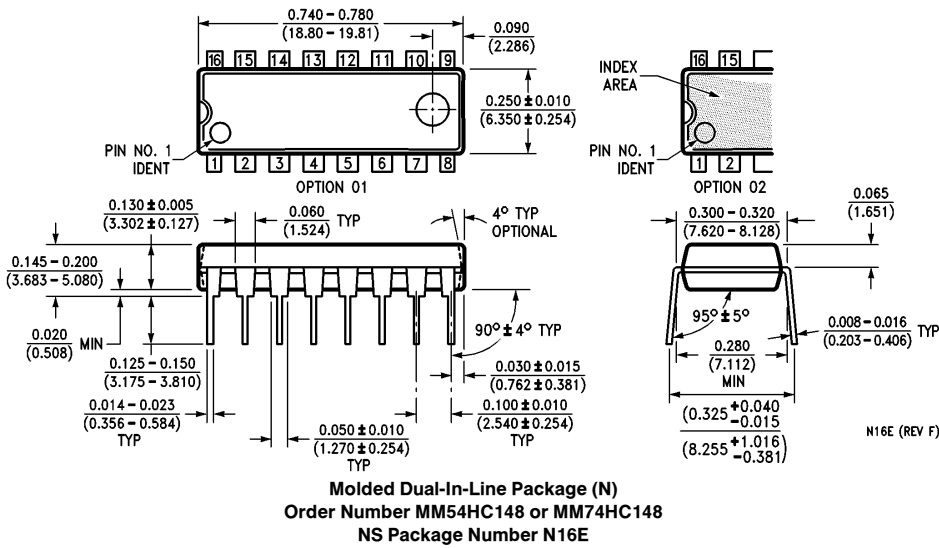

LIFE SUPPORT POLICY

NATIONAL'S PRODUCTS ARE NOT AUTHORIZED FOR USE AS CRITICAL COMPONENTS IN LIFE SUPPORT DEVICES OR SYSTEMS WITHOUT THE EXPRESS WRITTEN APPROVAL OF THE PRESIDENT OF NATIONAL SEMICONDUCTOR CORPORATION. As used herein:

1. Life support devices or systems are devices or systems which, (a) are intended for surgical implant into the body, or (b) support or sustain life, and whose failure to perform, when properly used in accordance with instructions for use provided in the labeling, can be reasonably expected to result in a significant injury to the user.
2. A critical component is any component of a life support device or system whose failure to perform can be reasonably expected to cause the failure of the life support device or system, or to affect its safety or effectiveness.



National Semiconductor Corporation
 1111 West Bardin Road
 Arlington, TX 76017
 Tel: 1(800) 272-9959
 Fax: 1(800) 737-7018

National Semiconductor Europe
 Fax: (+49) 0-180-530 85 86
 Email: cnjwge@tevm2.nsc.com
 Deutsch Tel: (+49) 0-180-530 85 85
 English Tel: (+49) 0-180-532 78 32
 Français Tel: (+49) 0-180-532 93 58
 Italiano Tel: (+49) 0-180-534 16 80

National Semiconductor Hong Kong Ltd.
 19th Floor, Straight Block,
 Ocean Centre, 5 Canton Rd.
 Tsimshatsui, Kowloon
 Hong Kong
 Tel: (852) 2737-1600
 Fax: (852) 2736-9960

National Semiconductor Japan Ltd.
 Tel: 81-043-299-2309
 Fax: 81-043-299-2408

National does not assume any responsibility for use of any circuitry described, no circuit patent licenses are implied and National reserves the right at any time without notice to change said circuitry and specifications.