

Top View of Assembly

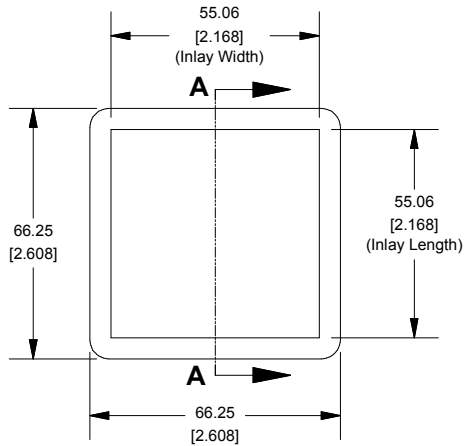

SECTION A-A (Side View Inside Assembly)

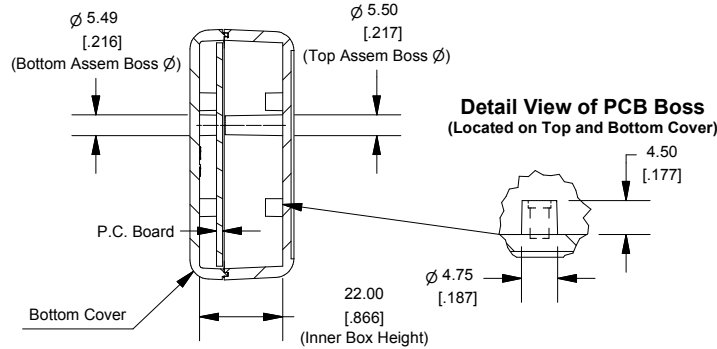

Hand Held Instrument (1593J)

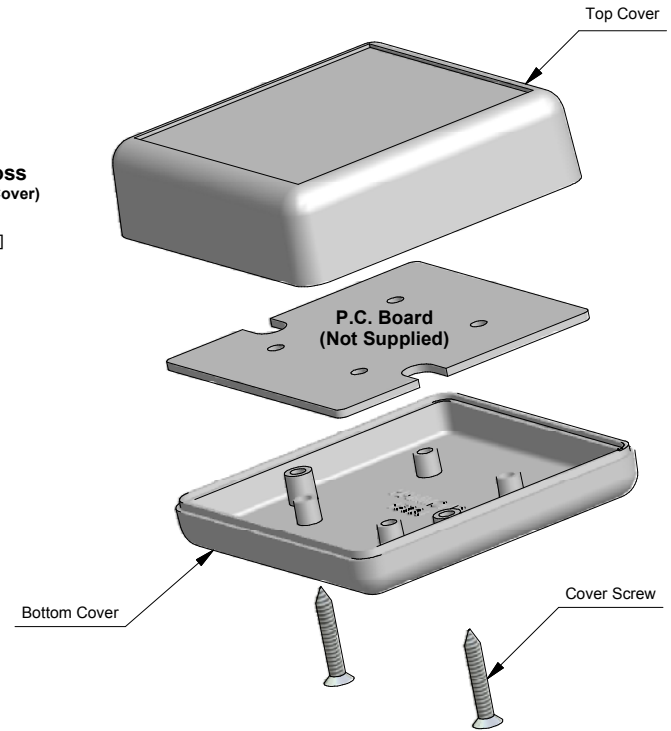

End View of Assembly

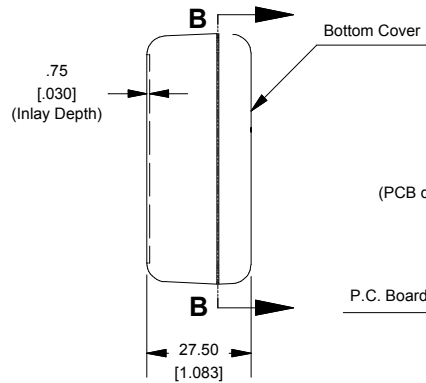

SECTION B-B (Inside of Bottom Cover)

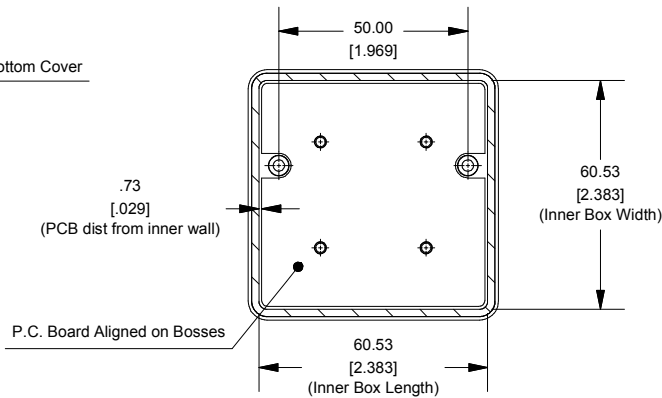

Maximum P.C. Board Size

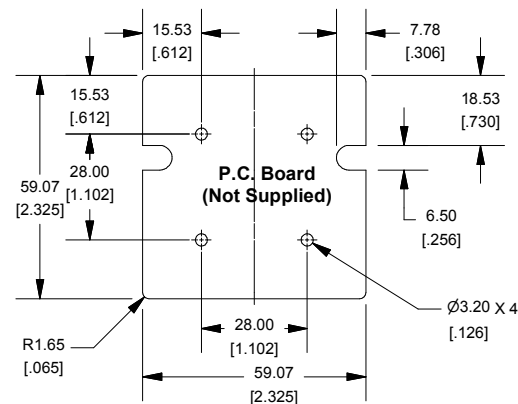

NOTE

Purchased assembly includes top and bottom cover and 2 cover screws.

PART NUMBERS

1593J Enclosure	
Black Enclosure	1593JBK
Grey Enclosure	1593JGY
ACCESSORIES	
Cover Screws (Pkg 100) [#4 x 3/4" self-tapping oval head (19.1mm)]	1593QS100
P.C. Board Screws [#4 x 1/4" self-tapping (6.4mm)]	1593ATS50 (Pkg. 50) 1593ATS100 (Pkg. 100)
Belt or Pocket Clip	1599CLIP (Black) 1599CLIPGY (Grey)



www.hammondmfg.com