

PAGING HORN SPEAKERS

SC-610/SC-610M



SC-615/SC-615M



SC-630/SC-630M



DESCRIPTION

TOA's SC Series Paging Horn Speakers are designed for both indoor and outdoor applications. The lineup includes six models rated at 10W (SC-610 and SC-610M), 15W (SC-615 and SC-615M) and 30W (SC-630 and SC-630M). The "M"-type models are designed for use in high-impedance (70V/100V lines) systems and standard models for low-impedance (8Ω) systems. This wide product lineup permits selection of the ideal speaker for most applications. SC Series speakers feature newly developed diaphragms employing special heat-resistant fibers impregnated with phenolic resin to prevent the diaphragm from absorbing moisture and changing shape. High speaker efficiency has also been realized by minimizing the gap produced when the diaphragm bobbin is installed in the magnetic circuitry slit. The aluminum foil bobbin also features excellent heat dissipation properties to resist high power inputs and ensure high speaker durability. □

All speakers feature TOA's unique oval shape, which enhances excellent speech clarity. □

The mounting brackets and all external hardware (screws, bolts) are made of stainless steel. The horn itself is treated with 50-micron thick powder paint coating, which is about three times thicker than that of the conventional horns. All of these factors combine to ensure the speaker's excellent weatherproofing and corrosion resistance. In addition, the external horn flare is made of aluminum which is more shock-resistant than resin. High-impedance models are equipped with an input impedance selector switch (4 steps for 100V line, and 5 steps for 70V line) which facilitates impedance settings without requiring disassembly. The switch is also equipped with an OFF position to prevent speaker damage resulting from incorrect impedance setting. □

□

FEATURES

- Both high-impedance (70V/100V lines) models and low-impedance (8Ω) models available. □
-
- Three power ratings: 10W, 15W and 30W. □
-
- Stainless steel brackets and hardware (screws, bolts), and powder-coated horn ensure superb weatherproofing and corrosion-resistance. □
-
- Shock-resistant aluminum oval horn. □
-
- Panel-mounted input impedance selector on high-impedance models facilitates input impedance matching. □
-
- Unobtrusive off-white color (corresponding to RAL 9010) helps speakers blend in with surroundings. □
-
- Compliance with IP65.

SC-610/SC-610M

CHARACTERISTIC DIAGRAMS

Frequency Response (1W/1m)

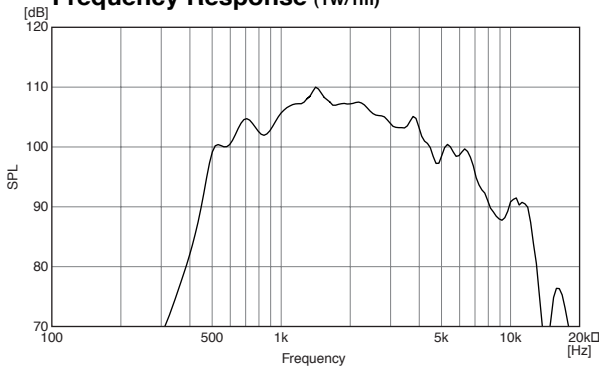

Beamwidth vs. Frequency (-6dB down point)

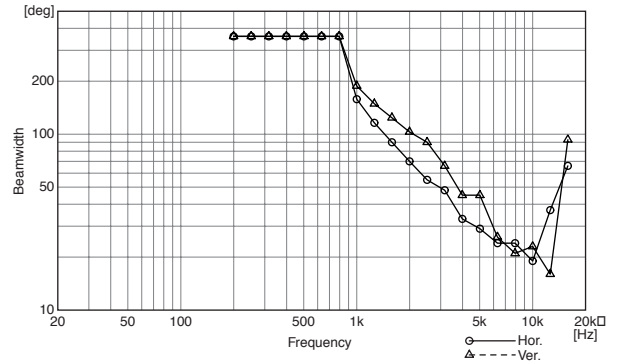

Directivity Factor vs. Frequency

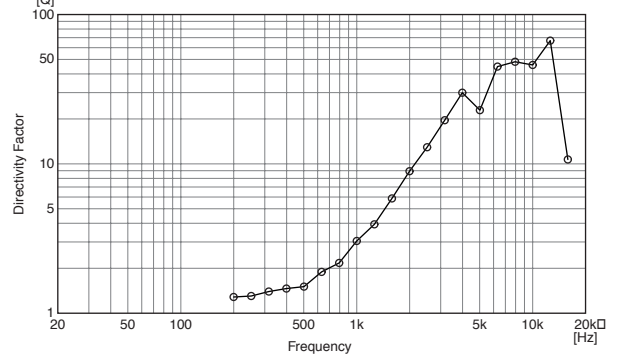

Polar Response

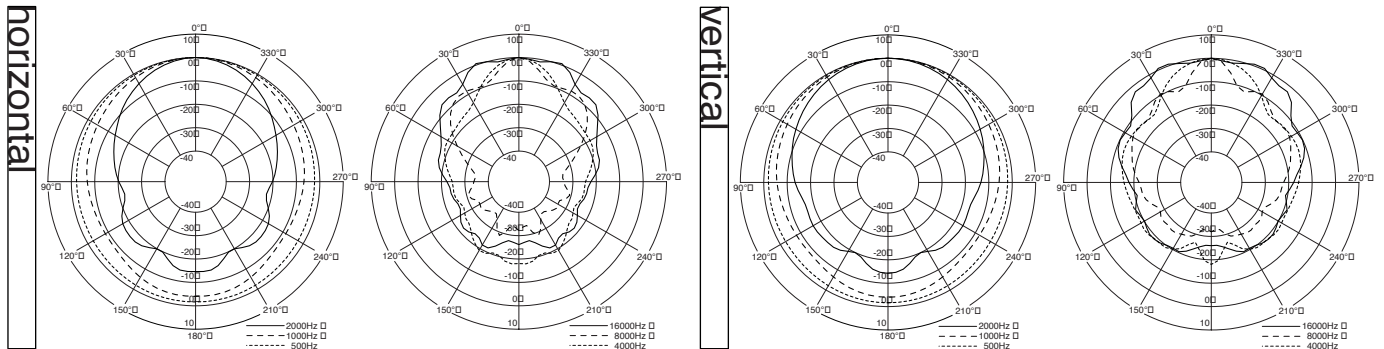

CHARACTERISTIC DIAGRAMS FOR USE AS MICROPHONE

Frequency Response

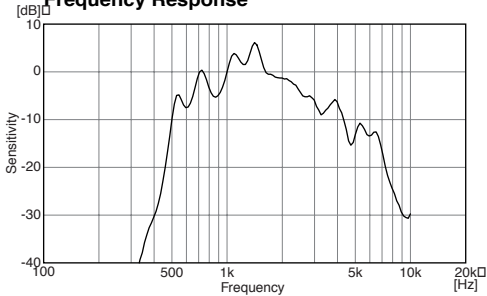

Beamwidth vs. Frequency (-6dB down point)

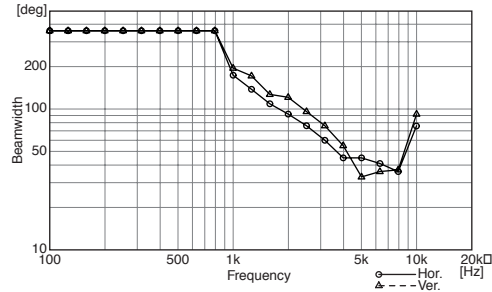

Polar Response

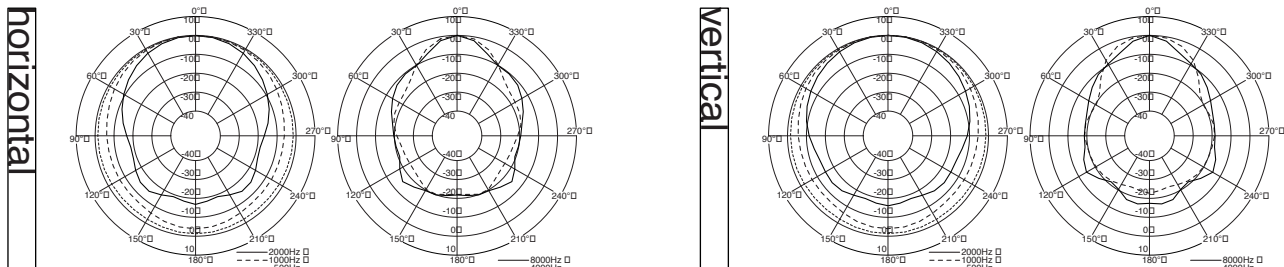

SC-615/SC-615M

CHARACTERISTIC DIAGRAMS

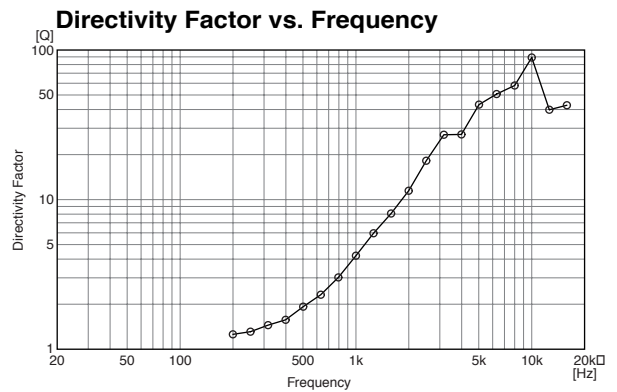
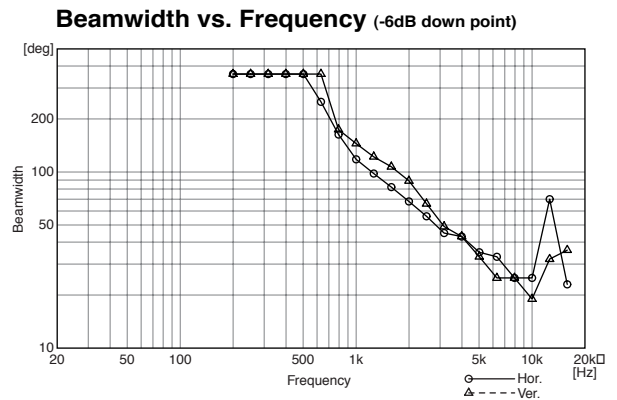
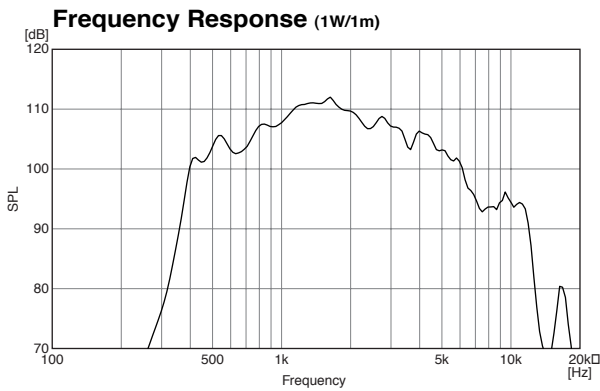

Polar Response

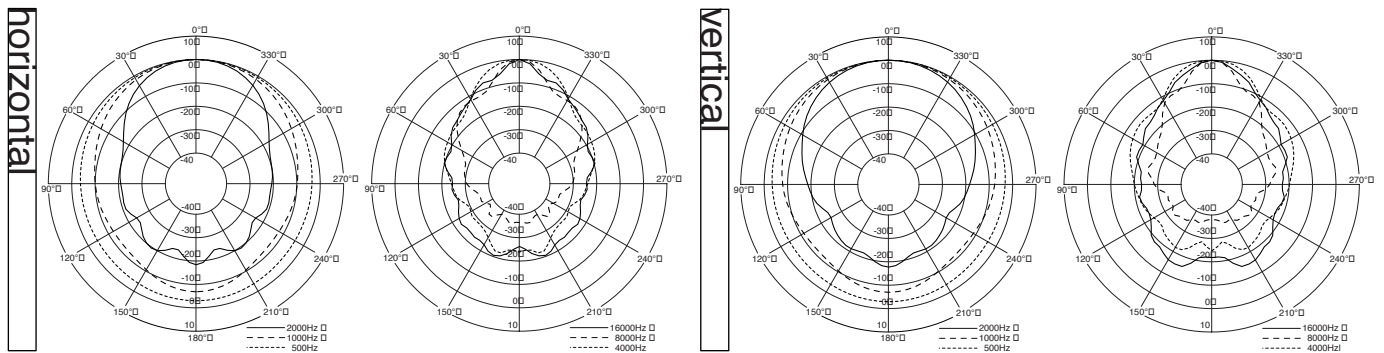

CHARACTERISTIC DIAGRAMS FOR USE AS MICROPHONE

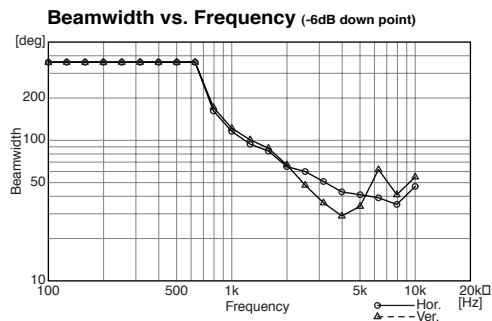
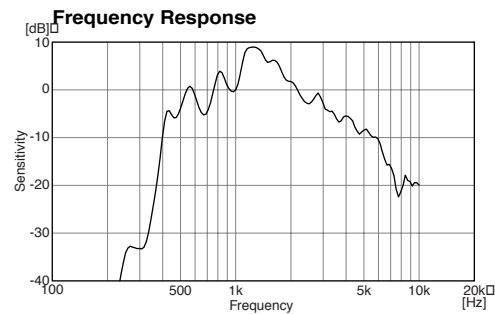

Polar Response

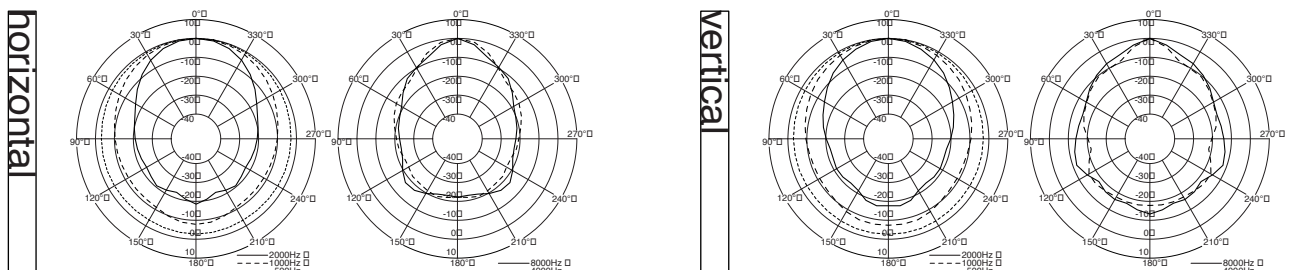

SC-630/SC-630M

CHARACTERISTIC DIAGRAMS

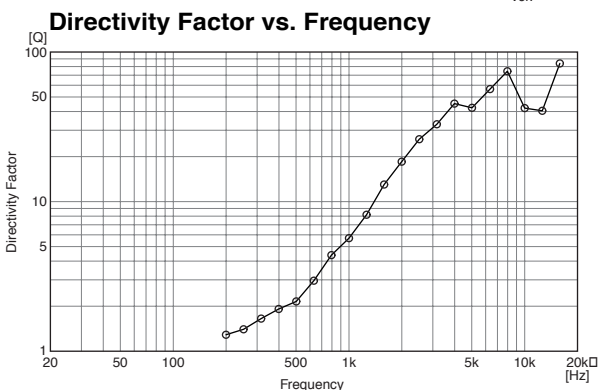
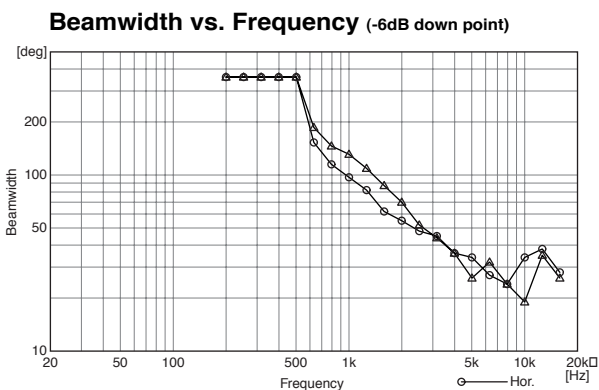
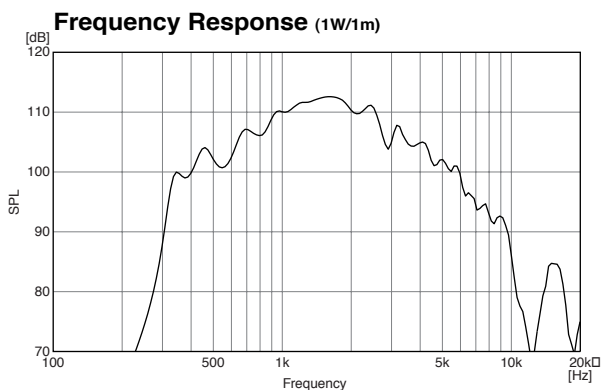

Polar Response

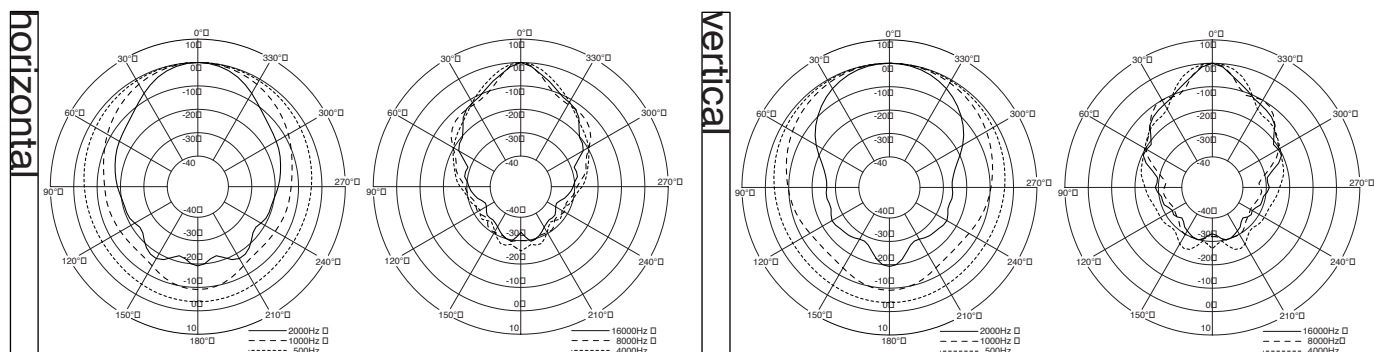

CHARACTERISTIC DIAGRAMS FOR USE AS MICROPHONE

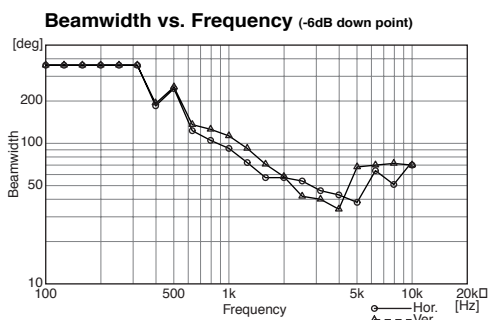
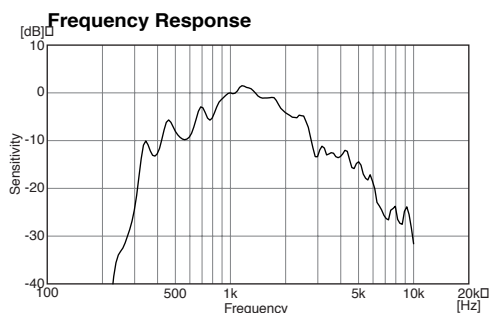

Polar Response

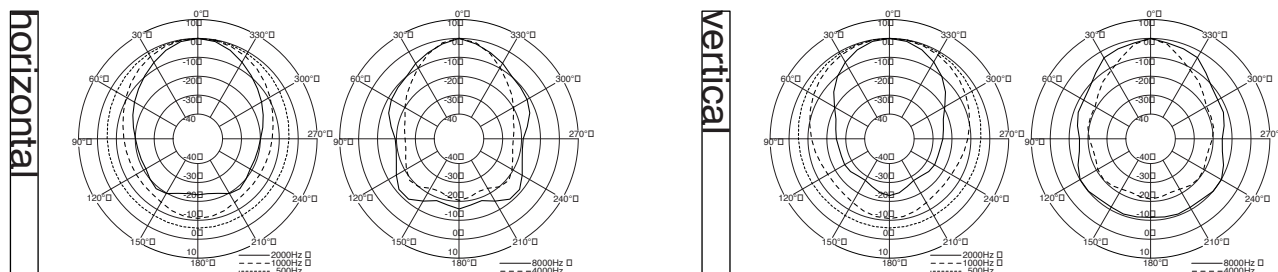

SPECIFICATIONS

	SC-610	SC-610M
Rated Input	10 W (Mobile Mount use: 5W)	10 W
Line Voltage	—	100 V line or 70 V line
Rated Impedance □ □ □ □	8 Ω	100 V line: 1 kΩ (10 W), 2 kΩ (5 W), 3.3 kΩ (3 W), 10 kΩ (1 W), 70 V line: 500 Ω (10 W), 1 kΩ (5 W), 2 kΩ (2.5 W), 3.3 kΩ (1.5 W), 10 kΩ (0.5 W)
Sound Pressure Level	110 dB (1 W, 1 m at 500 to 2,500 Hz peak level)	
Frequency Response	315 – 12,500 Hz	
Sensitivity when used as Microphone □ (0 dB = 1 mW/10 dynes/cm ²)	□	-24 dB at 1 kHz
IP Code	IP 65	
Polarity	Hot: Black, Com: White	
Operating Temperature	-20°C to +55°C (must be free from dew condensation)	
Finish □ □ □ □ □	Horn flare: Aluminum, off-white, powder coating Reflector horn and rear cover: ABS resin, off-white Bracket, Screws and bolts: Stainless steel Speaker cable: Polyvinyl chloride insulated cabtyre cable (6 mm in diameter, 600 mm in length)	
Dimensions	172 (W) x 161 (H) x 188 (D) mm	
Weight	1 kg	1.2 kg
Option	Swivel bracket: YS-151S (Can be used instead of the supplied bracket.)	

	SC-615	SC-615M
Rated Input	15 W (Mobile Mount use: 10W)	15 W
Line Voltage	—	100 V line or 70 V line
Rated Impedance □ □ □ □	8 Ω	100 V line: 670 Ω (15 W), 1 kΩ (10 W), 2 kΩ (5 W), 3.3 kΩ (3 W), 70 V line: 330 Ω (15 W), 670 Ω (7.5 W), 1 kΩ (5 W), 2 kΩ (2.5 W), 3.3 kΩ (1.5 W)
Sound Pressure Level	112 dB (1 W, 1 m at 500 to 2,500 Hz peak level)	
Frequency Response	280 – 12,500 Hz	
Sensitivity when used as Microphone □ (0 dB = 1 mW/10 dynes/cm ²)	□	-22 dB at 1 kHz
IP Code	IP 65	
Polarity	Hot: Black, Com: White	
Operating Temperature	-20°C to +55°C (must be free from dew condensation)	
Finish □ □ □ □ □	Horn flare: Aluminum, off-white, powder coating Reflector horn and rear cover: ABS resin, off-white Bracket, Screws and bolts: Stainless steel Speaker cable: Polyvinyl chloride insulated cabtyre cable (6 mm in diameter, 600 mm in length)	
Dimensions	222 (W) x 179 (H) x 234 (D) mm	
Weight	1.1 kg	1.3 kg
Option	Swivel bracket: YS-151S (Can be used instead of the supplied bracket.)	

	SC-630	SC-630M
Rated Input	30 W (Mobile Mount use: 15W)	30 W
Line Voltage	—	100 V line or 70 V line
Rated Impedance □ □ □ □	8 Ω	100 V line: 330 Ω (30 W), 670 Ω (15 W), 1 kΩ (10 W), 2 kΩ (5 W), 70 V line: 170 Ω (30 W), 330 Ω (15 W), 670 Ω (7.5 W), 1 kΩ (5 W), 2 kΩ (2.5 W)
Sound Pressure Level	113 dB (1 W, 1 m at 500 to 2,500 Hz peak level)	
Frequency Response	250 – 10,000 Hz	
Sensitivity when used as Microphone □ (0 dB = 1 mW/10 dynes/cm ²)	□	-20 dB at 1 kHz
IP Code	IP 65	
Polarity	Hot: Black, Com: White	
Operating Temperature	-20°C to +55°C (must be free from dew condensation)	
Finish □ □ □ □ □	Horn flare: Aluminum, off-white, powder coating Reflector horn and rear cover: ABS resin, off-white Bracket, Screws and bolts: Stainless steel Speaker cable: Polyvinyl chloride insulated cabtyre cable (6 mm in diameter, 600 mm in length)	
Dimensions	285 (W) x 227 (H) x 277 (D) mm	
Weight	1.7 kg	2 kg
Option	Swivel bracket: YS-151S (Can be used instead of the supplied bracket.)	

APPEARANCE AND DIMENSIONAL DIAGRAMS

SC-610/SC-610M

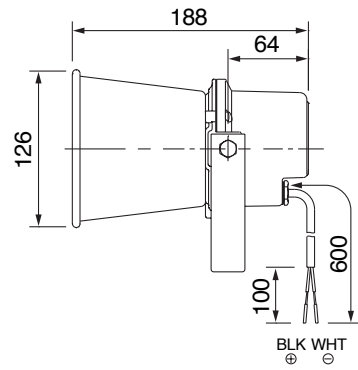
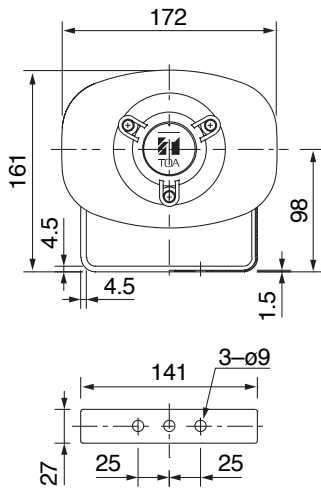

SC-615/SC-615M

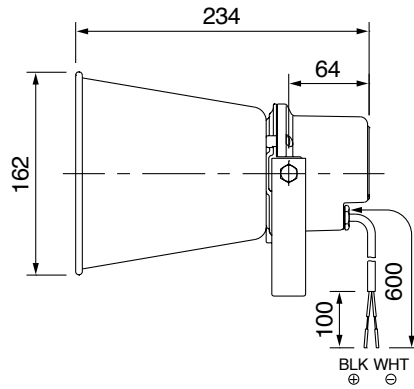
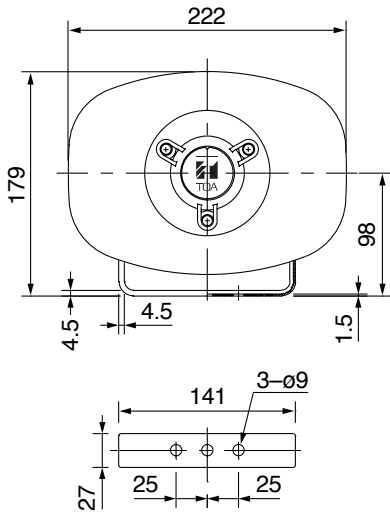

SC-630/SC-630M

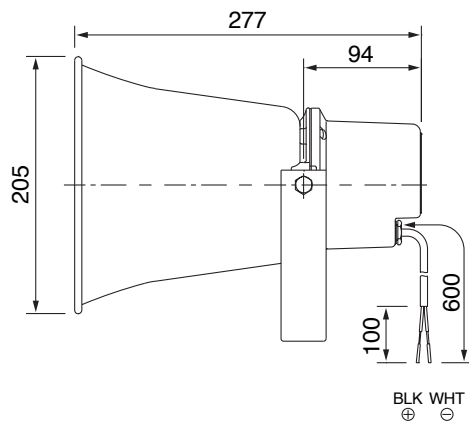
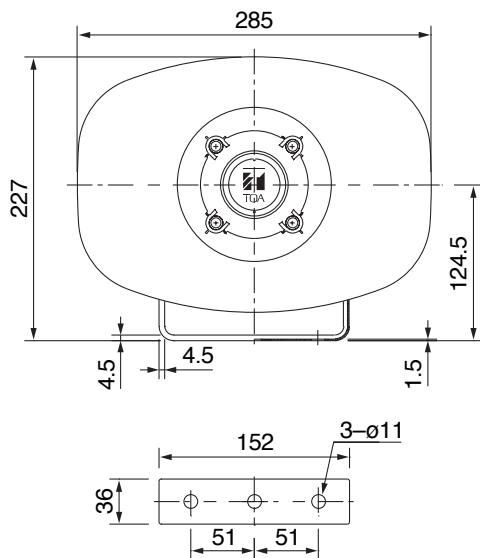

Unit: mm