

## Mini Vortex Mixer (Analog Speed) OHAUS VXMNAL

LQ1512AS

- **Sturdy design**
- **Variable, analog speed control**
- **Continuous or touch mode operation**



### Description

Built sturdy to provide stable and reliable vortexing action. Control allows low RPM startup for gentle shaking or high speed mixing for vigorous vortexing of samples. Two modes of operation; continuous mode when using accessory attachments or touch mode which activates mixing when depressing the cup head.

### Operating Conditions

Unit can be run in conditions from 4 to 40°C, 20% to 85% relative humidity, non-condensing.

### Includes

Cup Head, 7.6 cm Head, 7.6 cm Rubber Head Cover

### Specifications

**Speed Range 230V (RPM)** 300 to 2500

**Orbit (mm)** 4.9

**Controls** Auto/Off/On Rocker Switch, Speed Knob (Variable 1 to 10 Dial Marks)

**Duty Rating** Intermittent duty

**Dimensions (L x W x H cm)** 21.1 x 12.2 x 16.5

**Ship Weight (kg)** 4.5

### Dimensions

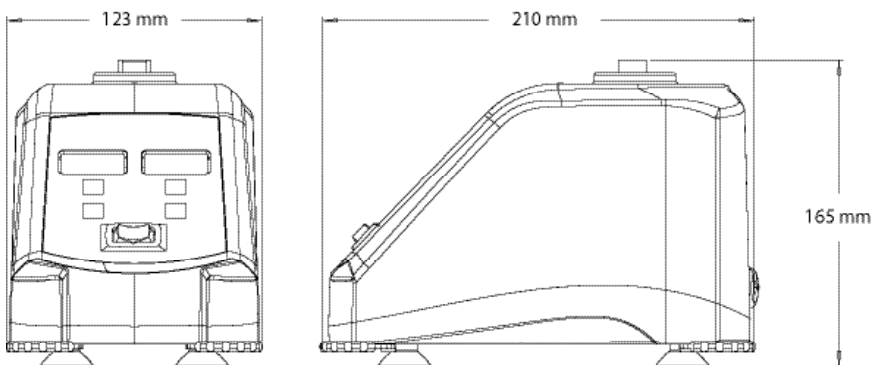

[www.wiltronics.com.au](http://www.wiltronics.com.au)