

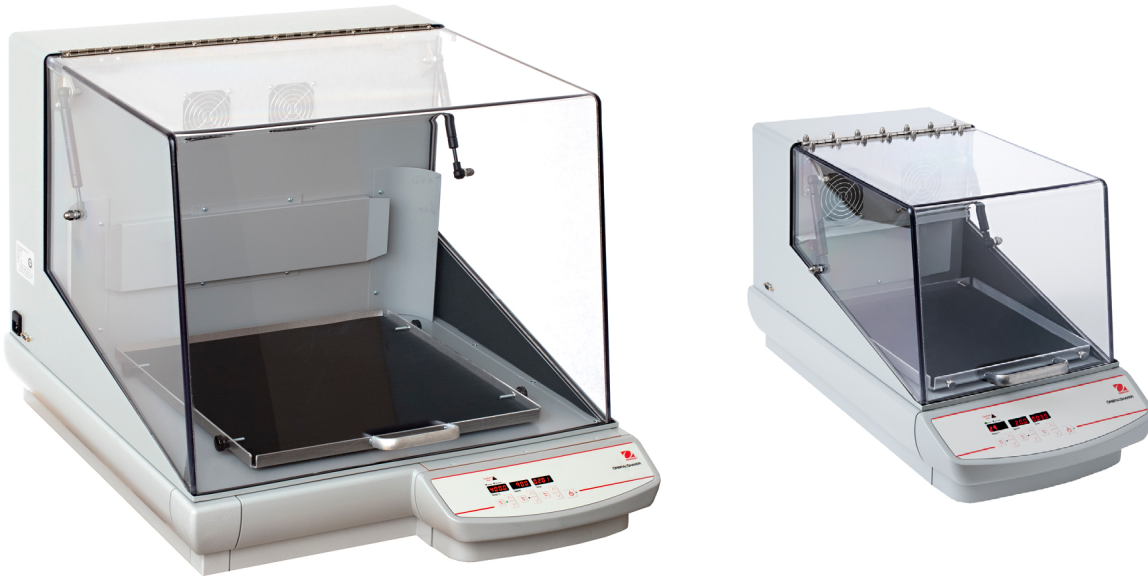

Incubating Heavy Duty Orbital Shakers



Save Incubator Space with Benchtop Incubating Shakers

Incubating Heavy Duty Orbital Shakers offer exceptional temperature uniformity and are designed for a variety of shaking and incubating applications.

Unique Features:

- The exclusive Opti-Flow Forced Ventilation System utilizes twin induction or a single large fan. Air is deflected around & not directly on samples, creating a circular flow of air ensuring uniformity.
- For repeatable results, the exclusive Accu-Drive shaking system ensures speed accuracy. The Triple Eccentric Drive provides consistent shaking motion throughout the entire speed range.
- The chamber for the ISHD23HDG is large enough to hold 2 x 6 L Erlenmeyer flasks with optional clamps and platform.

Incubating Heavy Duty Orbital Shakers

Specifications

Model	ISHD16HDG	ISHD23HDG
Motion	Orbital, 19 mm	Orbital, 25 mm
Speed Range	15 rpm to 500 rpm	
Speed Accuracy	Above 100 rpm +/-1% / Under 100 rpm +/- 1 rpm	
Temperature Range	Ambient +5 °C to 65 °C	
Temperature Uniformity	+/- 0.5 °C at 37 °C	
Calibration	Temperature Calibration	
Timer	1 second to 160 hours	
Control	Digital	
Communication	RS-232 Interface	
Max Weight Capacity	16 kg @ 75 rpm, 2.3 kg @ 500 rpm	22.7 kg @ 125 rpm, 4.53 kg @ 500 rpm
Drive System	Triple Eccentric; Brushless DC motor	
Dimensions (H x L x W)	40.6 x 64.8 x 35.6 cm	59.6 x 81.5 x 67.5 cm
Interior Dimensions (H x L x W)	24.1 x 34 x 30.5 cm	43.2 x 52.3 x 62.9 cm
Total Height with Lid-Open	84 cm	114 cm
Tray Dimensions (L x W)	33 x 27.9 cm	45.6 x 45.7 cm
Net Weight	35.9 kg	101.6 kg
Power	230 V, 50/60 Hz	230V, 50/60 Hz
Power Consumption	450 W	800 W
Working Environment	15 °C – 32 °C, 80% RH*, non-condensing	

*RH = Relative Humidity

Dimensional Drawings

ISHD16HDG

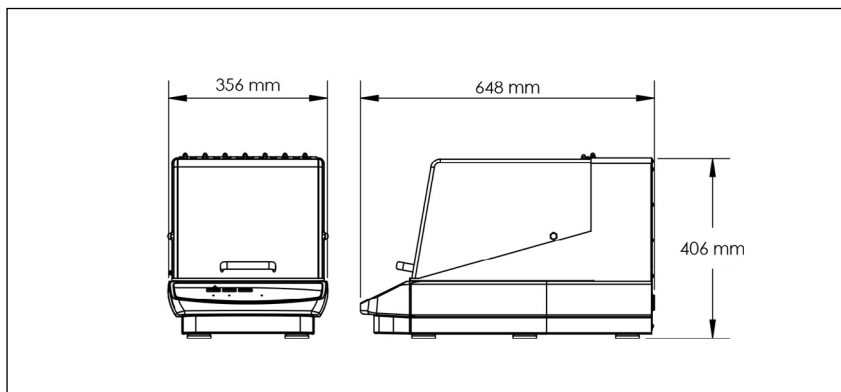

ISHD23HDG

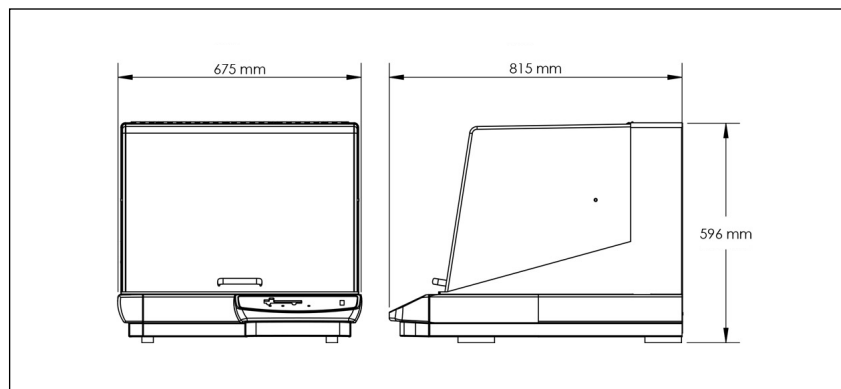

Incubating Heavy Duty Orbital Shakers

Accessories

Description	Part Number	Tube capacity per Rack	ISHD16HDG	ISHD23HDG
Universal Platform, 28 x 33 cm, S/S*	30400052	-	1	N/A
Universal Platform, 46 X 46 cm, S/S I-IR*	30400055	-	N/A	1
Rubber Mat, 28 x 33 cm	30400060	-	1	N/A
Flask Clamps, 10 mL	30400084	-	60	113
Flask Clamps, 25 mL	30400085	-	25	64
Flask Clamps, 50 mL	30400086	-	13	32
Flask Clamps, 125 mL	30400087	-	10	20
Flask Clamps, 250 mL	30400088	-	9	20
Flask Clamps, 500 mL	30400089	-	7	13
1 Liter Erlynmeyer Flask Clamp	30400090	-	4	8
2 Liter Erlynmeyer Flask Clamp	30400091	-	N/A	5
2.8 Liter Erlynmeyer Flask Clamp	30400092	-	N/A	2
3 Liter Erlenmeyer Flask Clamp	30400093	-	N/A	2
4 Liter Erlynmeyer Flask Clamp	30400094	-	N/A	4
5 Liter Erlenmeyer Flask Clamp	30400095	-	N/A	4
6 Liter Erlynmeyer Flask Clamp	30400096	-	N/A	2
500 mL Media Bottle Clamp	30400097	-	5	16
1000 mL Media Bottle Clamp	30400098	-	2	10
Flask Clamp Pvc 125 mL	30400099	-	10	20
Flask Clamp Pvc 250 mL	30400100	-	8	18
Flask Clamp Pvc 500 mL	30400101	-	5	12
Flask Clamp Pvc 1000 mL	30400102	-	2	8
Flask Clamp Pvc 2000 mL	30400103	-	N/A	4
Clamp Microplate SS	30400104	-	4	12
Tube Rack 1.5-2mL	30400114	70	2	4
Test Tube Rack 10-13 mm Diameter	30400115	63	2	4
Test Tube Rack 14-16 mm Diameter	30400116	48	2	4
Test Tube Rack 18-20 mm Diameter	30400117	35	2	4
Test Tube Rack 22-25 mm Diameter	30400118	24	2	4
Test Tube Rack For 15 mL Tubes	30400119	35	2	4
Test Tube Rack For 50 mL Tubes	30400120	12	2	4
Test Tube Rack 13 mm Pivoting	30400105	90	1	2
Test Tube Rack 16 mm Pivoting	30400106	60	1	2
Test Tube Rack 20 mm Pivoting	30400107	40	1	2
Test Tube Rack 25 mm Pivoting	30400108	24	1	2
Test Tube Rack 30 mm Pivoting	30400109	21	1	2
Test Tube Rack 10-14 mm Stationary	30400110	48	N/A	3
Test Tube Rack 16-20 mm Stationary	30400111	33	N/A	3
Test Tube Rack 21-25 mm Stationary	30400112	21	N/A	3
Test Tube Rack 50 mL Tubes Stationary	30400113	17	N/A	3

*All units require an accessory platform for mounting flask clamps or test tube racks.

Incubating Heavy Duty Orbital Shakers



Universal Platform, 28 x 33 cm, S/S*
30400052

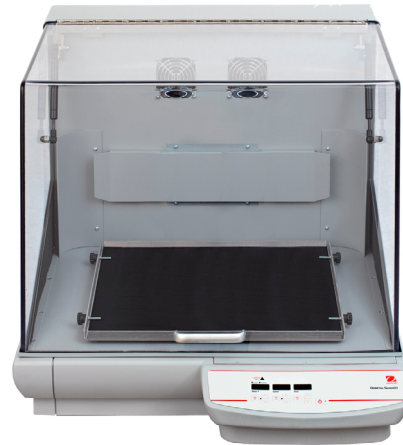

Universal Platform, 46 X 46 cm, S/S I-IR*
30400055



Other Standard Features & Equipment

Aluminum and Cycloy construction, temperature calibration feature, overload protection, overshoot protection (temperature), load sensor, PID temperature controller, Triple Eccentric Drive system

Compliance

- Product Safety: IEC/EN 61010-1; IEC/EN 61010-2-010; IEC/EN 61010-2-051
- Electromagnetic Compatibility: IEC/EN 61326-1 Class A, Basic Environments
- Compliance Marks: CE; RCM; TÜV SÜD; WEEE

80776579_G_20241224 © Copyright OHAUS Corporation

**OHAUS Asia/Pacific
Headquarters**
e-mail: APmarketing@ohaus.com
Tel: +86 21 64855408

www.ohaus.com

*The management system
governing the manufacture
of this product is
ISO 9001:2015 certified.*



*All units require an accessory platform for mounting flask clamps or test tube racks.