

GENERAL SPECIFICATION

TIEM	DESCRIPTION				
Product No	SC2004ASLB-XH-HS				
LCD Type	<input checked="" type="checkbox"/> STN Gray Positive	<input type="checkbox"/> STN Yellow Green Positive		<input type="checkbox"/> STN Blue Negative	
	<input type="checkbox"/> TN Negative		<input type="checkbox"/> TN Positive		
Rear Polarizer	<input type="checkbox"/> Reflective		<input checked="" type="checkbox"/> Transflective		<input type="checkbox"/> Transmissive
Backlight Type	<input checked="" type="checkbox"/> LED	<input type="checkbox"/> Internal Power		<input type="checkbox"/> EL	<input type="checkbox"/> 5V input
Backlight Color	<input type="checkbox"/> White	<input type="checkbox"/> Amber	<input type="checkbox"/> Blue Green	<input checked="" type="checkbox"/> Yellow Green	<input type="checkbox"/> Blue
View Direction	<input checked="" type="checkbox"/> 6 O'clock			<input type="checkbox"/> 12 O'clock	
Temperature Range	<input type="checkbox"/> Normal			<input checked="" type="checkbox"/> Wide	
Frame	<input type="checkbox"/> Black		<input checked="" type="checkbox"/> Silver		

TO BE VERY CAREFUL !

The LCD driver ICs are made by CMOS process, which are very easy to be damaged by static charge, make sure the user is grounded when handling the LCM.

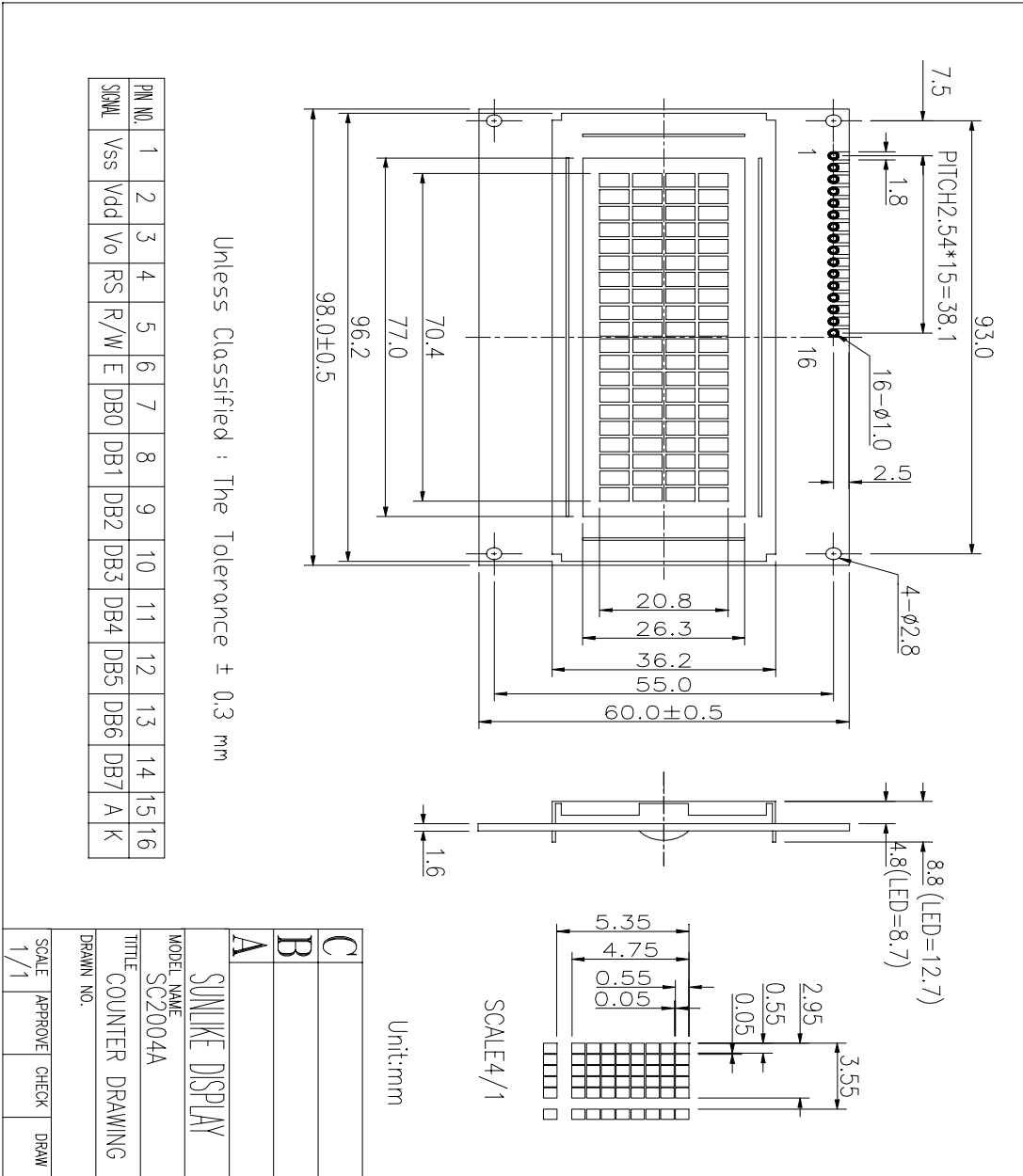

ABSOLUTE MAXIMUM RATING

(1) Electrical Absolute Ratings

Item	Symbol	Min.	Max.	Unit	Note
Power Supply for Logic	$V_{DD}-V_{SS}$	-0.3	7.0	Volt	
Power Supply for LCD	$V_{DD}-V_O$	-0.3	12.0	Volt	
Input Voltage	V_I	-0.3	V_{DD}	Volt	
LED Power Dissipation	P_{AD}	-	136	mW	
LED Forward current	I_{AF}	-	40	mA	
LED Reverse Voltage	V_R	-	5	V	

(2) Environmental Absolute Maximum Ratings

Item	Normal Temperature				Wide Temperature			
	Operating		Storage		Operating		Storage	
	Min,	Max.	Min,	Max.	Min,	Max.	Min,	Max.
Ambient Temperature	0°C	+50°C	-20°C	+70°C	-20°C	+70°C	-30°C	+80°C
Humidity(without condensation)	Note 2,4		Note 3,5		Note 4,5		Note 4,6	

Note 2 $T_a \leq 50^\circ\text{C}$: 80% RH max

$T_a > 50^\circ\text{C}$: Absolute humidity must be lower than the humidity of 85%RH at 50°C

Note 3 T_a at -20°C will be <48hrs at 70°C will be <120hrs when humidity is higher than 70%.

Note 4 Background color changes slightly depending on ambient temperature. This phenomenon is reversible.

Note 5 $T_a \leq 70^\circ\text{C}$: 75RH max

$T_a > 70^\circ\text{C}$: absolute humidity must be lower than the humidity of 75%RH at 70°C

Note 6 T_a at -30°C will be <48hrs, at 80°C will be <120hrs when humidity is higher than 70%.

ELECTRICAL CHARACTERISTICS

Item	Symbol	Condition	Min.	Typ	Max.	Unit	note
Power Supply for Logic	$V_{DD}-V_{SS}$	-	4.5	5.0	5.5	Volt	
Input Voltage	V_{IL}	L level	0	-	0.6	Volt	
	V_{IH}	H level	2.2	-	V_{DD}	Volt	
LCM Recommend LCD Module Driving Voltage	$V_{DD}-V_O$	$T_a=0^{\circ}C$	-	-	-	Volt	
		$T_a=25^{\circ}C$	4.2	4.5	4.8		
		$T_a=50^{\circ}C$	-	-	-		
Power Supply Current for LCM	I_{DD}	$V_{DD}=5.0V$ $V_{DD}-V_O=4.5V$	-	3.0	4.0	mA	
LED Forward Voltage	V_F	$I_f=20\text{ mA}$	-	6.8	7.0	Volt	
LED Forward Current	I_F	-	-	20	-	mA	
LED Reverse Current	I_R	$V_R=5V$	-	-	0.2	mA	

OPTICAL CHARACTERISTICS

Item	Symbol	Condition	Min.	Typ	Max.	Unit	note
Viewing angle range	$\Phi f(12\text{ o'clock})$	When $Cr \geq 1.4$	-	10	-	Degree	9,10
	$\Phi b(6\text{ o'clock})$		-	30	-		
	$\Phi l(9\text{ o'clock})$		-	30	-		
	$\Phi r(3\text{ o'clock})$		-	30	-		
Rise Time	T_r	$V_{DD}-V_O=4.5V$ $T_a=25^{\circ}C$	-	200		mS	
Fall Time	T_f		-	250			
Frame frequency	F_{rm}		-	64	-	Hz	
Contrast	Cr		-	3.0	-		7
The Brightness Of Backlight	L	$I_F=20\text{ mA}$	30	35	-	cd/m^2	
Peak Emission Wavelength	λP		-	570	-	nm	

MECHANICAL SPECIFICATION

ITEM	DESCRIPTION
Product No.	SC2004A
Module Size	98.0(W)×60.0(H)×12.7 max(D)
View Area	77.0(W)×26.3(H)
Dot Size	0.55 (W)mm×0.55(H)mm
Dot Pitch	0.60(W)mm×0.60(H)mm
Display Format	20 characters (W)×4 lines (H)
Duty Ratio	1/16 Duty
Controller	KS0066 or Equivalent

INTERFACE PIN ASSIGNMENT

Pin No.	Pin Out	Level	Description
1	VSS	0V	Power Supply Ground
2	VDD	5V	Power Supply Voltage
3	Vo	---	Contrast Adj
4	RS	H/L	Register Select
5	R/W	H/L	Read / Write
6	E	H,H→L	Enable Signal
7	DB0	H/L	Data Bit 0
8	DB1	H/L	Data Bit 1
9	DB2	H/L	Data Bit 2
10	DB3	H/L	Data Bit 3
11	DB4	H/L	Data Bit 4
12	DB5	H/L	Data Bit 5
13	DB6	H/L	Data Bit 6
14	DB7	H/L	Data Bit 7
15	A	4.2V	LED Power Supply (+)
16	K	0V	LED Power Supply (-)

[Note 7] Definition of Operation Voltage (Vop)

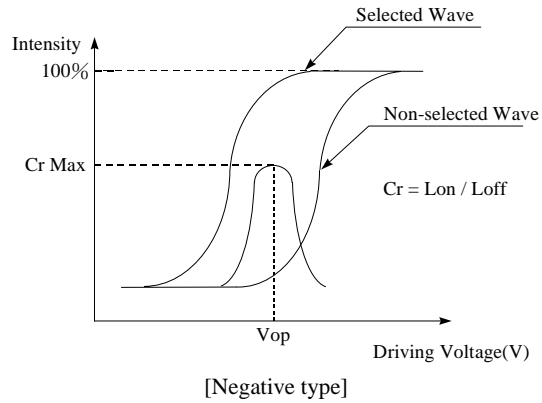
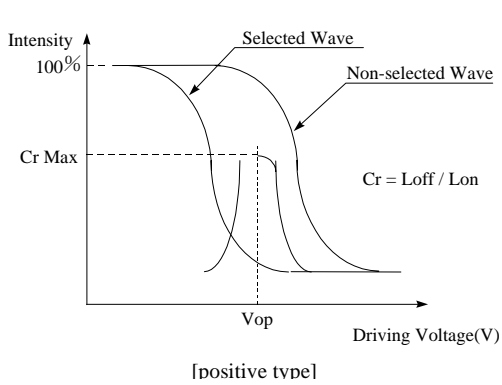

[Note 8] Definition of Response Time (Tr, Tf)

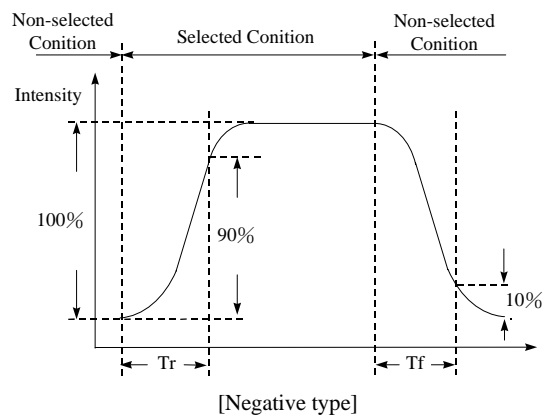
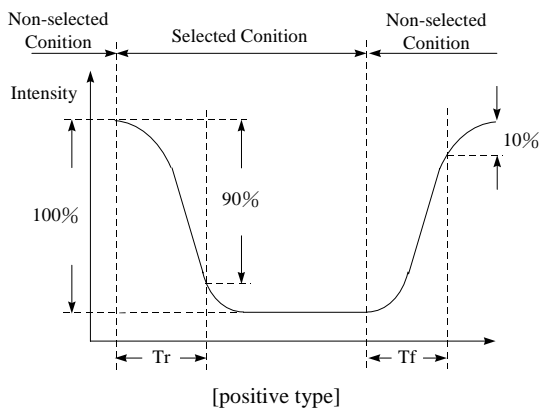

Conditions:

Operating Voltage : Vop

Frame Frequency : 64 Hz

Viewing Angle (θ, φ): $0^\circ, 0^\circ$

Driving Wave form : 1/N duty, 1/a bias

[Note 9] Definition of Viewing Direction

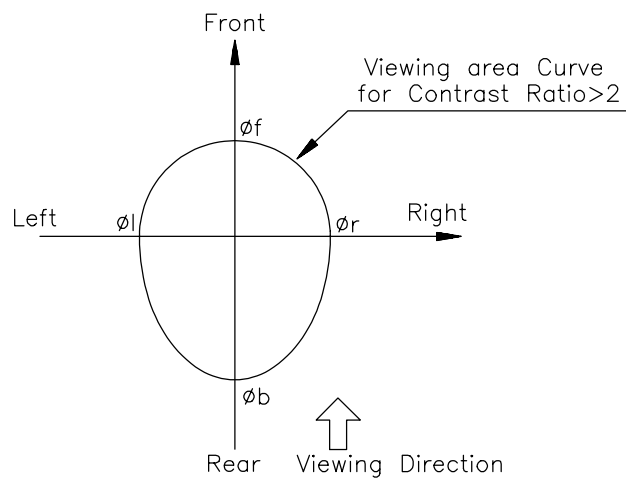

[Note 10] Definition of viewing angle

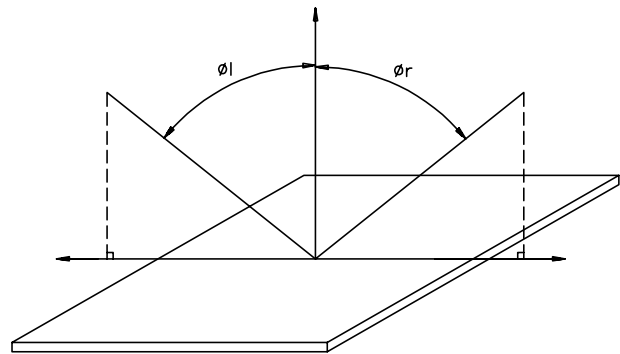
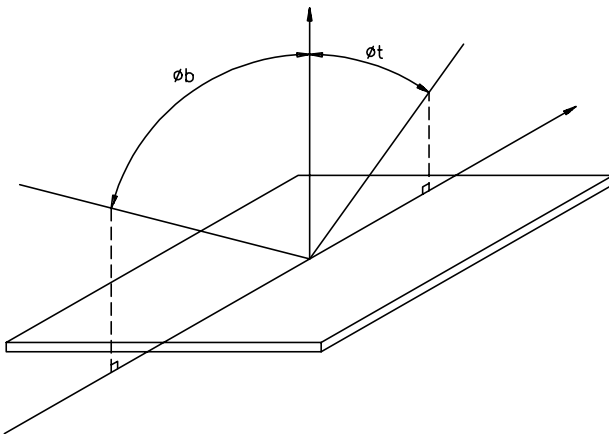

[Note 11] Description of Measuring Equipment

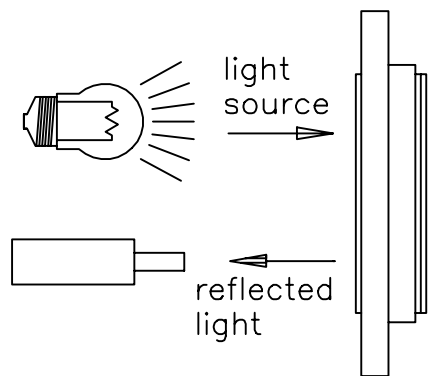

Reflective type

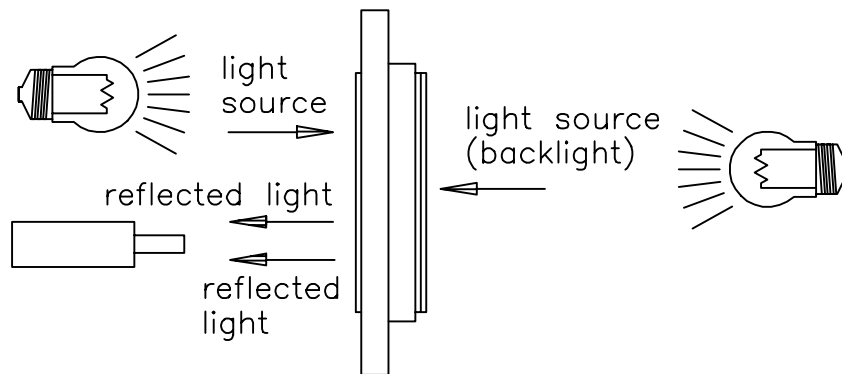

Transflective type

BLOCK DIAGRAM

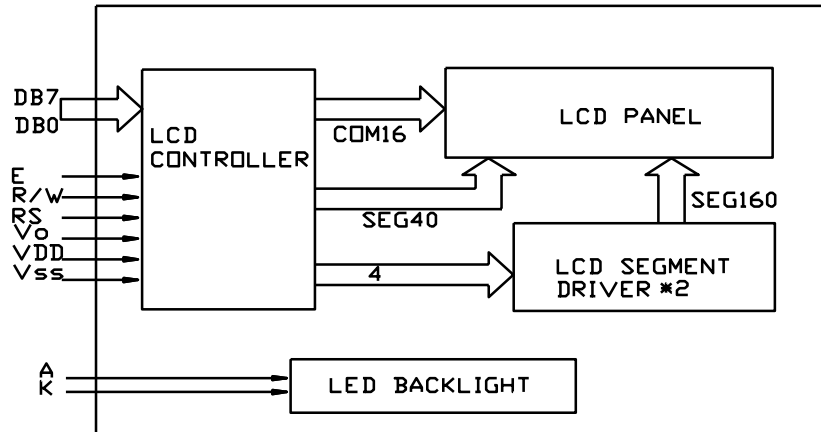

POWER SUPPLY

